

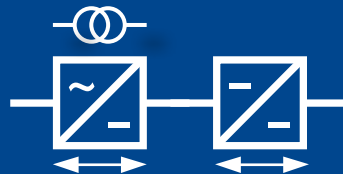

**KVALITEST**  
— INDUSTRIAL —



# *Infeed Test System*



▶ **TYPE I-TS-3870 & TYPE MI-TS-3871**



## Infeed Test System – Type I-TS-3870

### General Data:

- Power single system up to 650 kW
- Total power parallel system up to 1.3 MW
- Output voltage single system up to 1000 V
- Output current single system up to 1000 A (higher output current on request)



### Typical applications:

- Battery simulation (BS)
- Battery test (BT)
- Testing fuel cell
- Testing solar panels
- Testing of charging stations (comemso)
- Power supply of trains

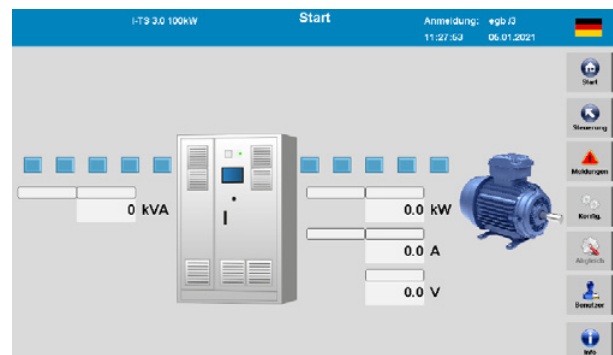
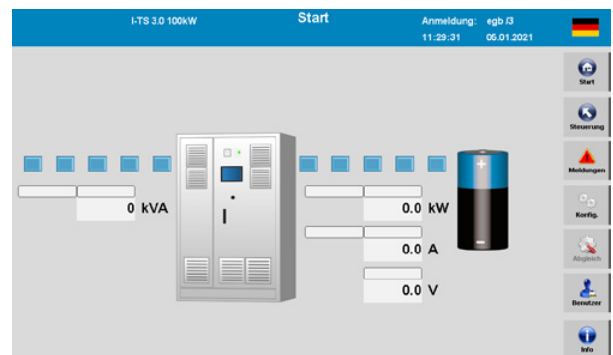

# Applications (depending on configuration)

## Infeed Test System – Type I-TS-3870:

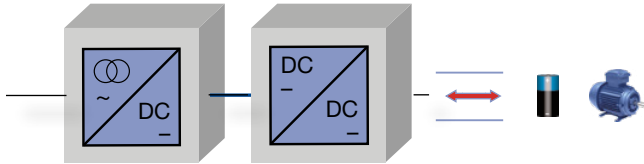

Test of battery charging and discharging

Load for fuel cells (with safety function)

Power supply and power deduction of powertrain

Testing power supply for fuses, contactors and MCCB

Test of DC-motors



source: Schaeffler



## Multi-Channel-Infeed-Test-System – Type MI-TS-3871

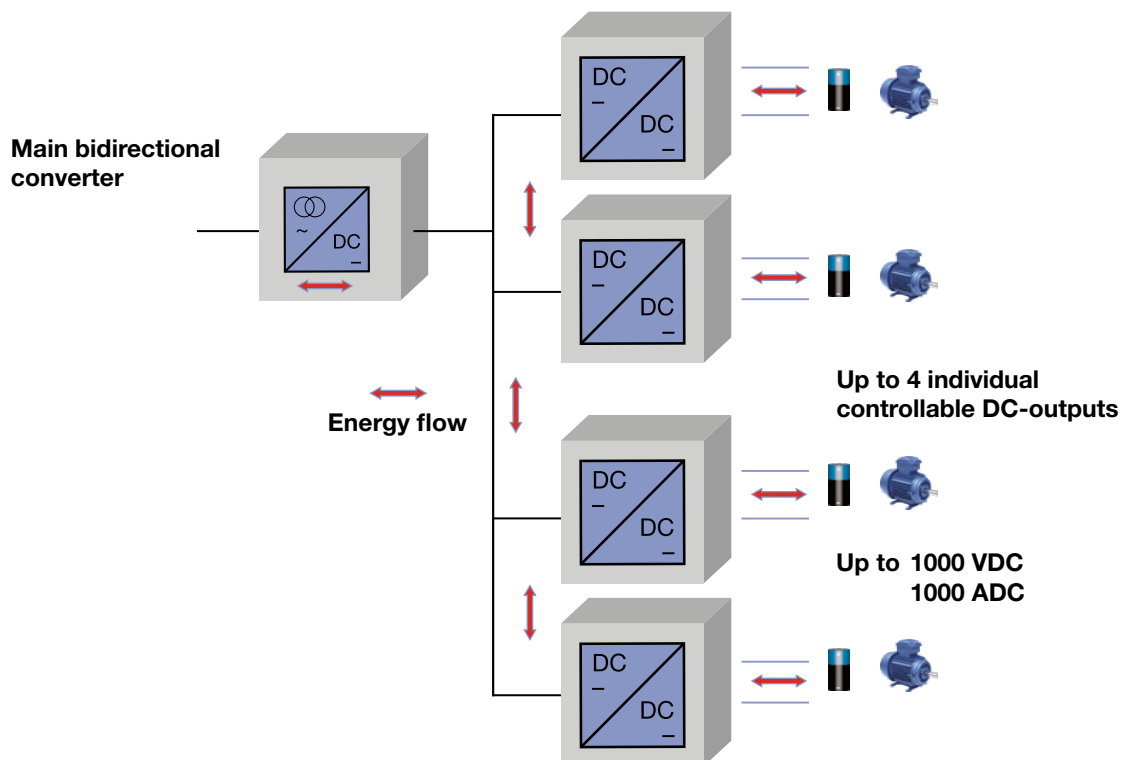

## Types / Technical data

Typ	Rated power (kW)	DC Voltage (V)	DC-Current (A)	Typical current rise time 10 % - 90 % (ms)
I-TS-3870-300	60-120	5-300	200-1000	< 1
I-TS-3870-600	60-500	5-600	200-1000	< 1
I-TS-3870-800	100-500	5-800	200-1000	< 1
I-TS-3870-1000	100-650	5-1000	200-1000	< 1,3

AC - Input voltage / AC – Input frequency	380 / <b>400*</b> / 440 / 480 / 500 / 690 V ±10 %, 3-phase, PE, 50 / 60 Hz ± 6 %
Measuring resolution	voltage: 16 Bit ADC current: 16 Bit ADC
Control accuracy	voltage 0.1 % fs current 0.1 % fs
Voltage tolerance dynamic (0 – 100 % INom in 3 ms)	< 3 % fs
Voltage ripple	≤ 0.1 % eff. fs
Current ripple	≤ 0.1 % eff. fs
Short circuit behavior	Short circuit proof (Ik < 3 kA)
Permissible ambient temperature	+5 to +40 °C
Climate class	1K21/1M11 according to EN60721 (85 % relative humidity non condensing with cabinet heating up to 95 % rel. humidity without condensing)
Distance from ceiling min.	300 (standard, IP20)
Installation	Operating area with restricted access installation on non-flammable floor
Protection class	IP20 according to IEC 60529 others on request
Safety	EN ISO 13849-1
Basic standard	EN 62040
EMC	EN 61000-2-4 grid disturbances EN 61000-6-2 interference immunity EN 61000-6-4 interference emission EN 61800-3 Kat C2 (A1) variable – speed electrical drives

Subject to change without notice (tech)

\* Standard 400 V

# Characteristics and basic equipment

- „Battery tester“ version
- Highly dynamic inverter
- Short circuit proof < 3 kA, < 8 kA at 1000 A systems
- Electrical isolation to grid
- Control accuracy 0.1 % fs
- Voltage ripple 0.1 % fs
- DC current measurement with 0.1 % fs accuracy
- Current rise time < 1 msec (300 - 800 V), < 1.3 msec (1000 V)
- Seamless transition source/sink
- Main switch (switch disconnecter with fuses in the AC input; lockable in Off-Position)
- Safety control for Performance Level d (PLd) in accordance with ISO 13849-1 / EN 60204-1
- TFT display with touch operation
- Stop button (black mushroom button) in cabinet door
- Voltmeter and ready indicator light in cabinet door
- DC output contactor
- Connection terminals for DC voltage measurement (0.1 % fs accuracy with sense lines)
- Connection terminals for external „Emergency Stop“
- Connection terminals for external „Stop“
- Connection terminals for calibrating case
- Interface MOD-bus / TCP-IP
- Interface CAN-bus („100 Hz“ with dbc file)
- Interface VNC over Ethernet
- Protection type IP20
- Air cooled
- High efficiency
- Noise-reduced version (rubber buffer, fan control)

## Version „Battery simulator“

### I-TS, 800 V DC, 600 A Small voltage dip at load step

- Setting: constant voltage
- Max. accepted deviation of voltage at load step 0-100 % in 3 msec: 1 % fs = 8 V
- Measuring of transient voltage deviation and control settling time

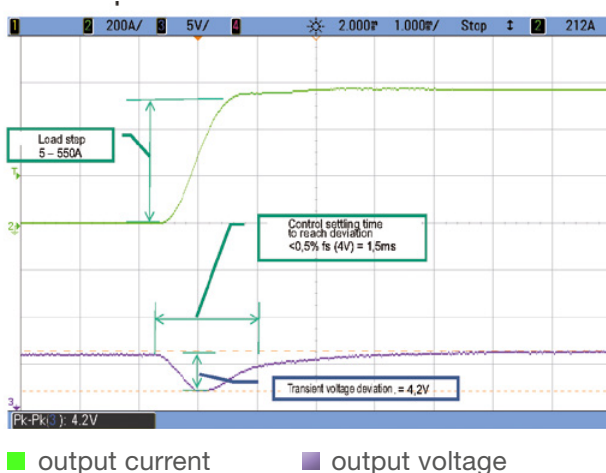

typical course

## Version „Battery tester“

### I-TS, 1000 V DC, 1000 A, 100 kW Fast current slew rate

- Output voltage 80 V DC
- Changing setpoint for current from - 1000 A to + 1000 A
- Measuring of current rise time (- 900 A to + 900 A) = 1.2 msec

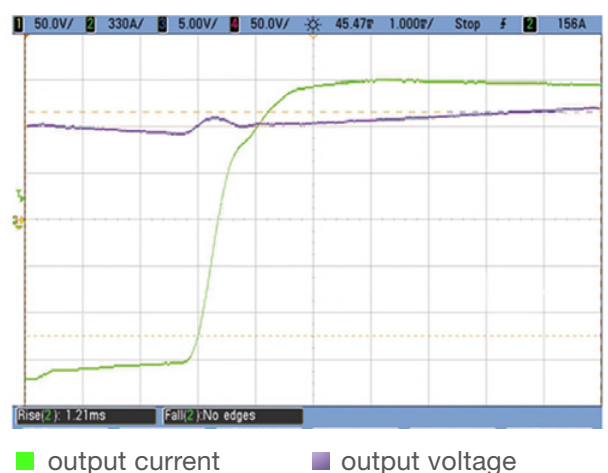

typical course

# Interfaces

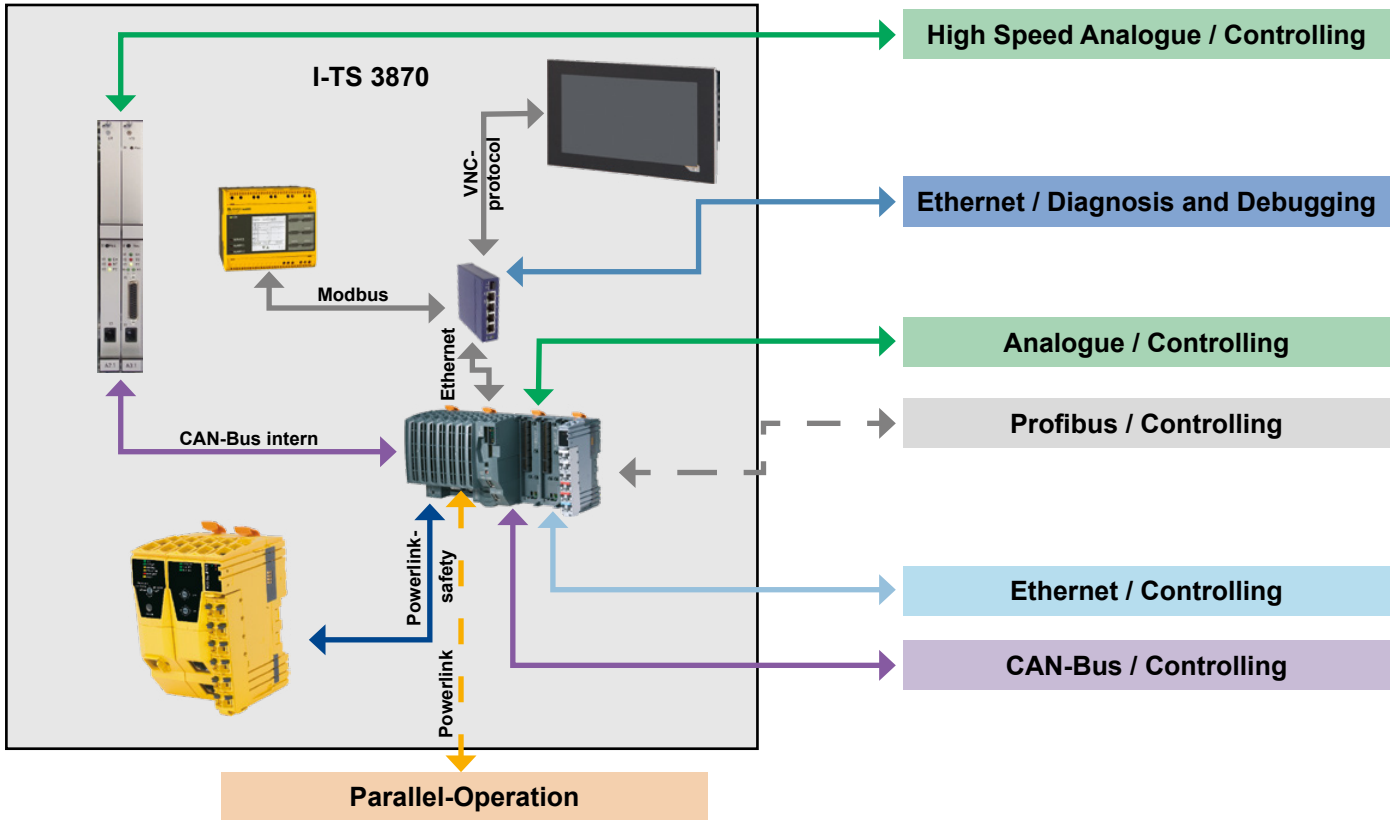

## Performance level „d“ (machine directive: EN ISO 13849-1)

- Redundant Hardware
- Redundant wiring
- Two separate channels
- Constant test of inputs and outputs
- Safe shutdown in case of error

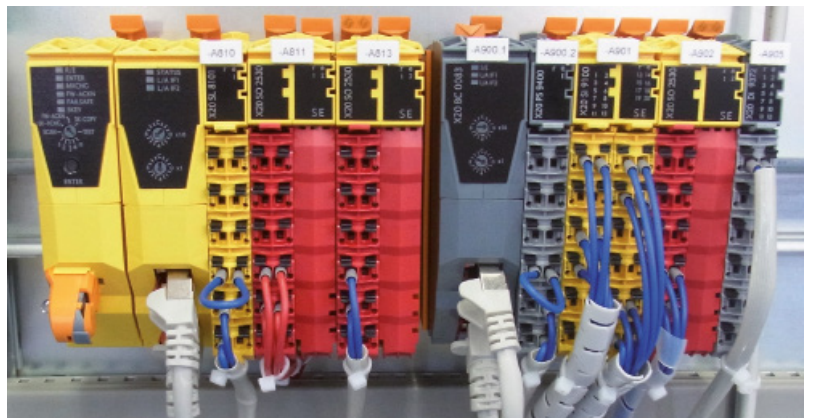

## Using batteries to increase max. power

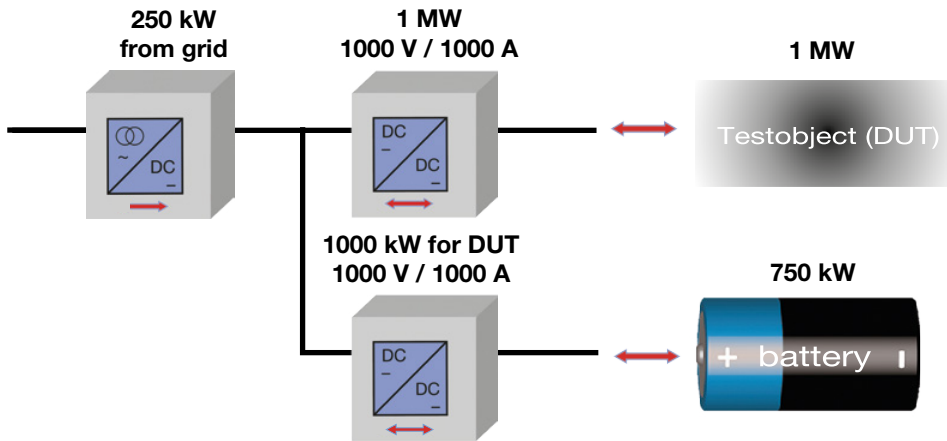

## Power supply with internal energy recovery for development and testing of e-powertrain

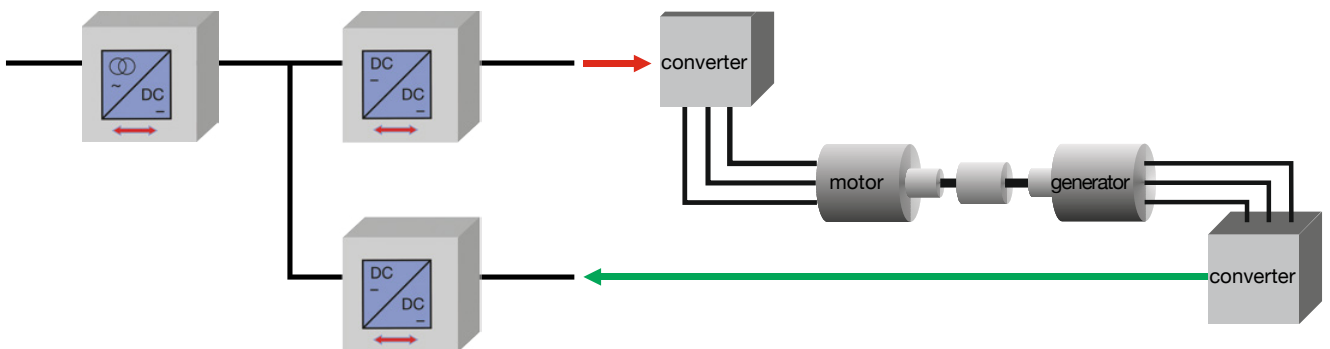

# Power supplies for internal devices during service and repair of high speed trains

I-TS 250 kW 670 V/375 A



ICE



Control device

© AST, Wolnzach

## Fuel cell testing

60 – 650 kW    1000 V / 1000 A

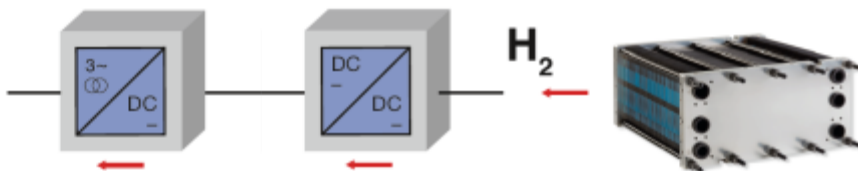



# DC application: EVSE Test (DC EV Simulation)

DC application: EVSE Test (DC EV-Simulation).

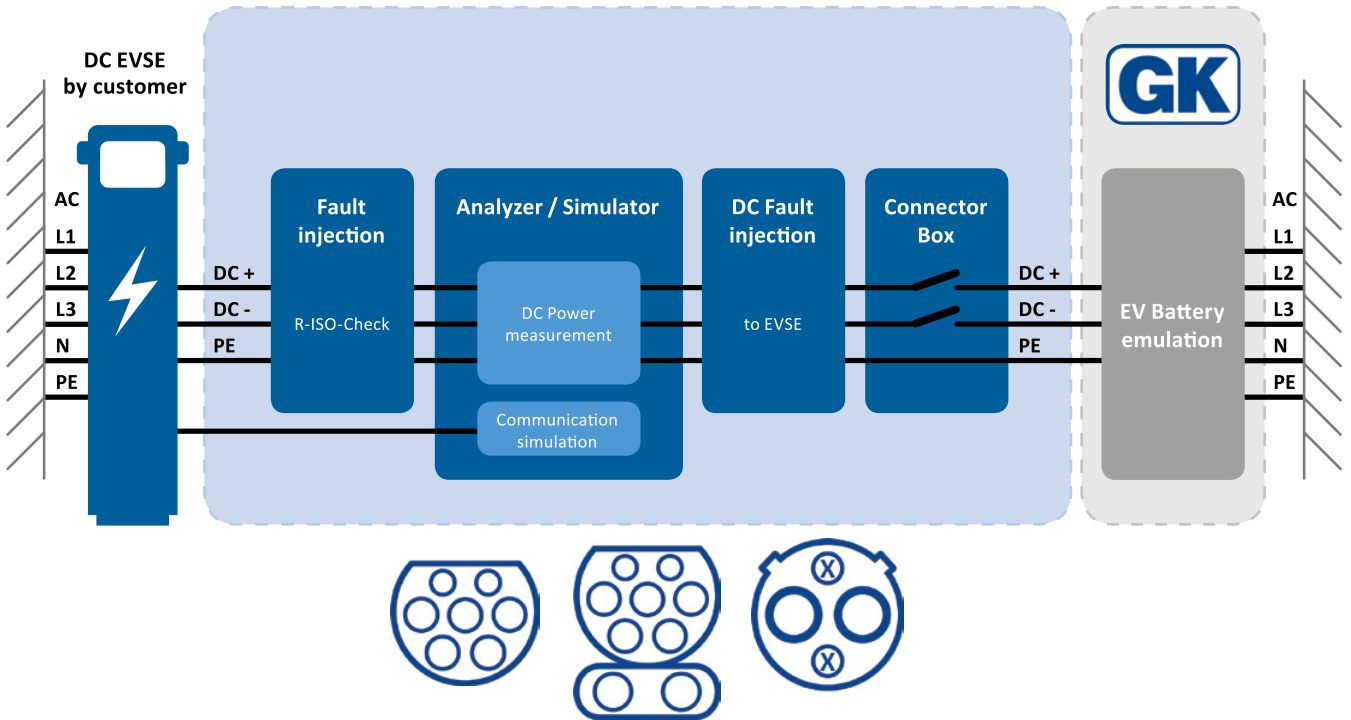

# DC application: EV Test (DC EVSE Simulation)

DC application: EV Test (DC EVSE-Simulation)

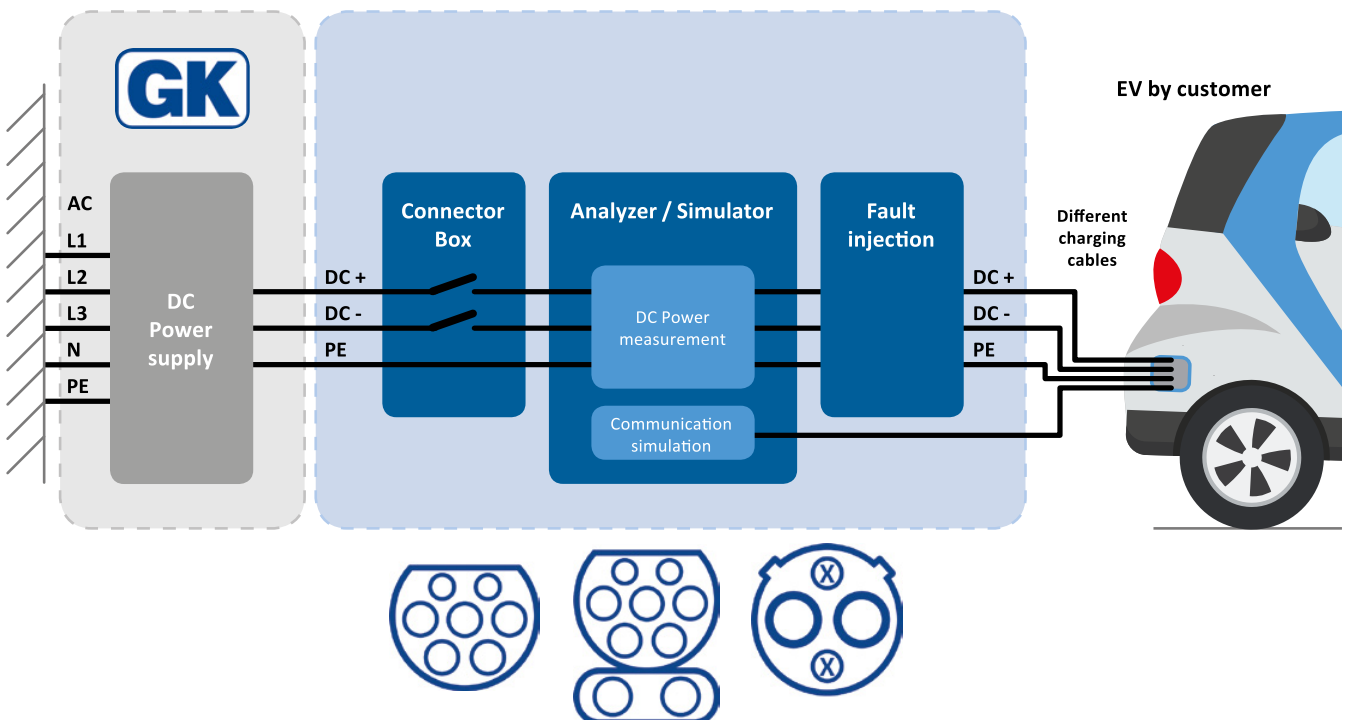

# Options

## 1. Adaptation to test application

- Insulation monitoring device
- Operating mode battery simulator
- Operating mode battery simulator/tester switchable
- Output contactor with increased short-time withstand current
- Current range switching 100% and 10%
- Protective diode for sink mode
- Parallel control device
- PDSB (cabinet for additional options)
- Discharge Unit
- PDU (cabinet for DUT connection)
- Capacity box
- Safety performance level „e“

## 3. Interfaces

- Remote contacts
- SCPI/EtherCAT/PROFIBUS/PROFINET
- Analogue
- High speed analogue I+
- High speed CAN (1 kHz)
- Remote control
- Matlab-Simulink
- Labview

## 5. Cabels and wires

- Halogen free cables
- Control cable/Sense cable/Power cable

## 2. Adaptation to customer specification

- Adaptation safe shutdown time
- Intermediate discharge DC-link
- Emergency stop at door
- Door contact/door interlock
- Special door lock
- Special input voltage
- Adaptation to USA/CAN market
- Cabinet lamp/cabinet heating
- Single-wire marking
- Cabinet type Rittal - VX
- Base frame control cabinet
- Cabinet on wheels
- Special paint

## 4. Protection class control cabinet

- IP21/IP22/IP23/IP54
- Increase protection class from below
- Increase Protection class at open door IPX0B
- Fire protection



Insulation monitoring device at DC output



DC-DC output contactor

<sup>[1]</sup> A discharge unit always assumes a PDSB. From a rectifier output

# Exemplary Applications

## I-TS-3870 Single – Standard System

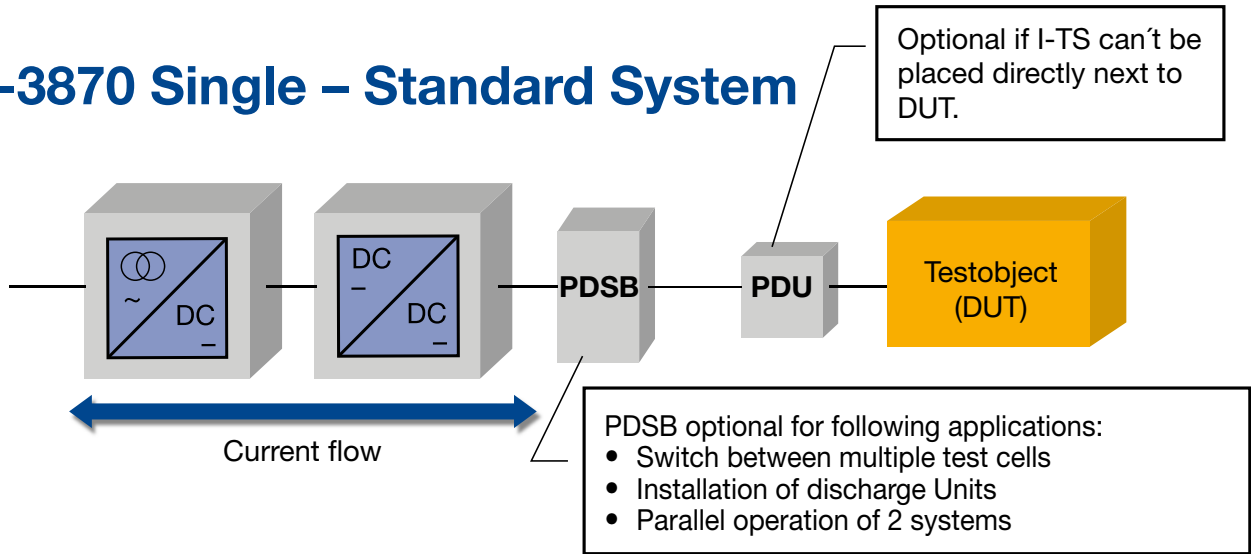

## Changeover Test Cells / DUT

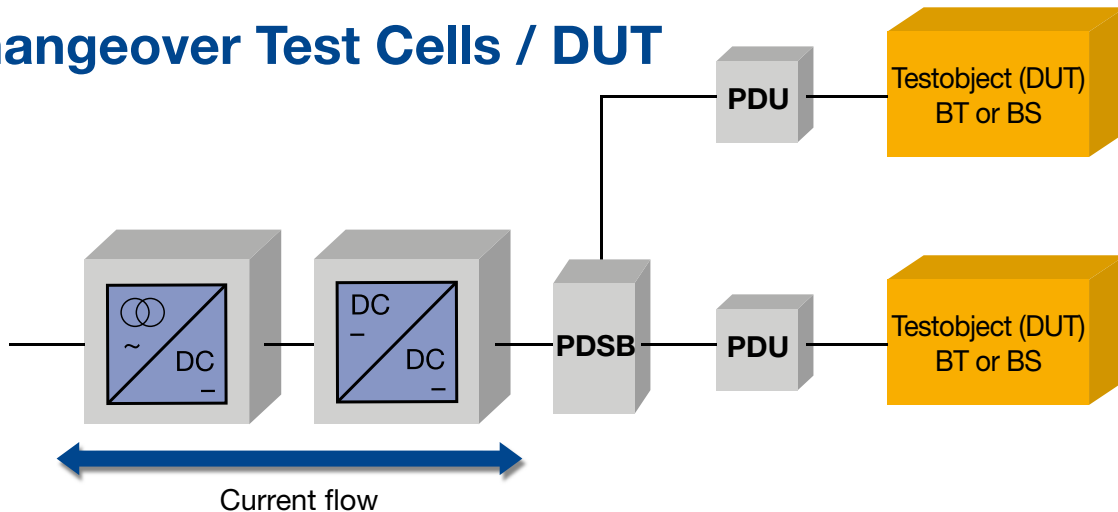

Testing one DUT and connecting simultaneously the second one

## I-TS-3870 Parallel – System

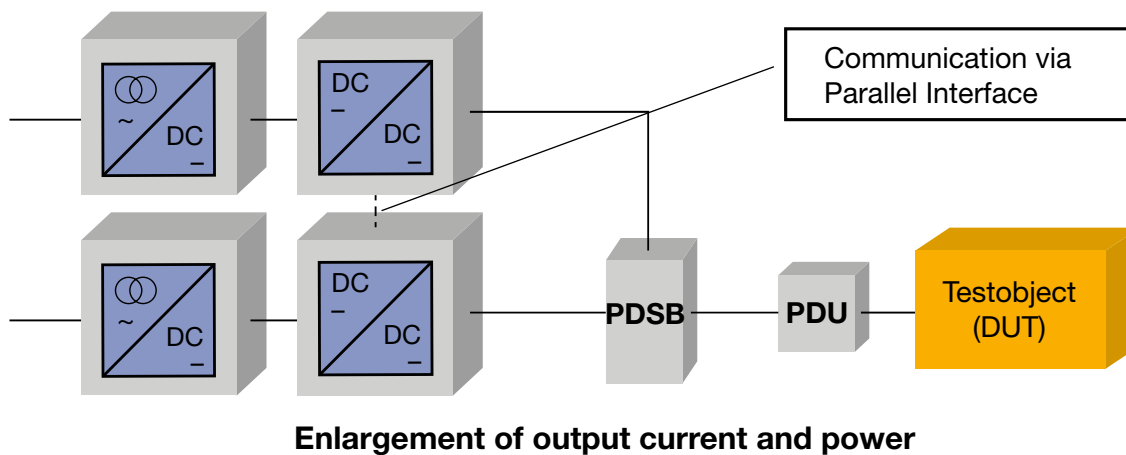



# ***Innovation and quality from Germany and Austria***



## **GUSTAV KLEIN GMBH & CO. KG**

D-86956 **Schongau** · Im Forchet 3  
D-86952 Schongau, Postfach 12 48  
Phone +49(0)8861/209-0, Fax +49(0)8861/209-180  
E-Mail: [vertrieb@gustav-klein.com](mailto:vertrieb@gustav-klein.com)  
[www.gustav-klein.com](http://www.gustav-klein.com)

A-6401 **Inzing**/Tirol · Schießstand 2  
Phone +43(0)5238/54209-0  
Fax +43(0)5238/54209-23  
E-Mail: [vertrieb@gustav-klein.com](mailto:vertrieb@gustav-klein.com)  
[www.gustav-klein.com](http://www.gustav-klein.com)

