

Move into the future with reliable measurements



Encapsulated Weldable Strain Gages

KHCX, KHCV, KHCR, KHCS, KHCM, KHC, KCW

Static/Dynamic Strain Measurement
at up to

950°C

(KHCX)



KYOWA Encapsulated

Contents

Types and Typical Applications 1

Features of High-temperature Models 2

Temperature Compensation Method and Bridge Circuit
(KHCX, KHCR, KHCS, KHCM, KHC) 3

Features of Normal-temperature Model 4

High-temperature Encapsulated Weldable Strain Gages

KHCX 5

KHCV 6

KHCR 7

KHCS 8

KHCM 9

KHC 10

Normal-temperature Encapsulated Weldable Waterproof Foil Strain Gage

KCW 12

Optional Accessories

Bridge Boxes DB-120A/L 13

Bridge Adapters 13

Compression Fitting 14

MI Cable Length Codes and Optional Accessories 14

Compact Spot Welder for Encapsulated Weldable Strain Gages 15

To Ensure Safe Usage of Encapsulated Weldable Strain Gages 16



Weldable Strain Gages

KYOWA encapsulated weldable strain gages are hermetically sealed. They consist of a sensing part and a cable to transmit output signals from the sensing part. The sensing part is composed of a metal tube and a flange. The highly heat-resistant metal tube has strain-gage element(s) and insulation material sealed in. The flange is spot-welded to the measuring point.

The cable is a mineral-insulated metal sheathed cable (MI cable) filled with heat-resistant insulating powder in which the leadwires are embedded.

This structure enables these strain gages to measure strain under harsh environments affected by high temperature, high pressure or high humidity.

High-temperature models can be applied to strain measurement in fields including nuclear/thermal power generation, automobiles and aircraft. The normal-temperature model features waterproof construction and long-term stability, and thus is suitable for outdoor strain measurement in the automobile, civil engineering, architectural and many other fields.

Types and Typical Applications

Type	Normal Temp.	High Temp.					
Model	KCW	KHC	KHCM	KHCS	KHCR	KHCV	KHCX
Measuring Strain	Static/Dynamic					Dynamic	Static/Dynamic
Max. Oprg. Temp.	100°C	500/550°C	650°C	750°C	750°C	800°C	950°C
Temp. Comp.	Yes					No	Yes

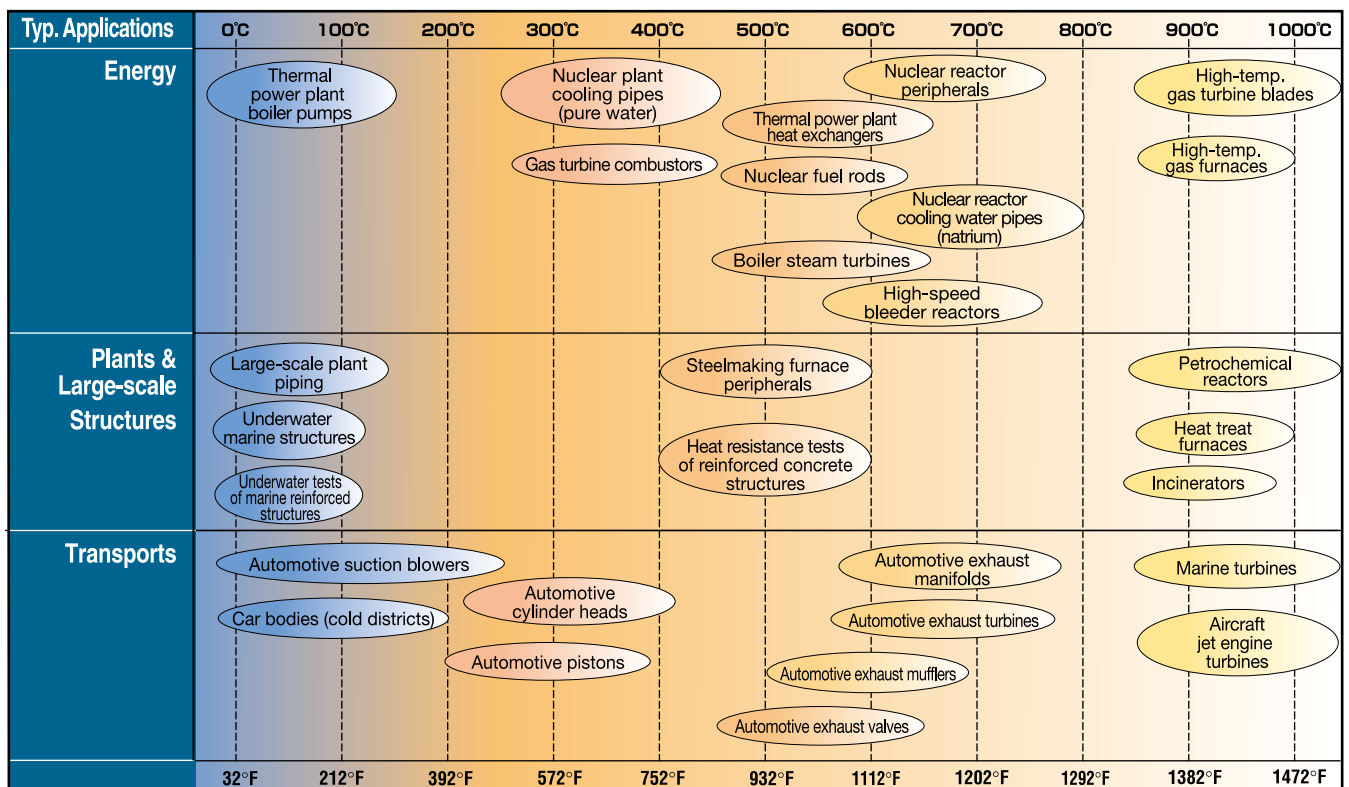

High-temperature Encapsulated Weldable Strain Gages

Features

Hermetically sealed structure provides excellent environmental capability.

The gage element and leadwire cable (MI cable) are covered with heat and corrosion resistant metal (Inconel 600, etc.) and integrated, enabling strain measurement at high temperatures or under high pressure, seawater or pure water.

Strain-gage element is made of heat-resistant special alloy.

Minimal thermally-induced apparent strain ensures highly accurate measurement (KHGX, KHCR, KHCS, KHCM, KHC).

The half-bridge structure has a dummy gage for temperature compensation, and the applicable linear expansion coefficient can be selected according to the measuring object. Furthermore, the temperature compensation resistor compensates apparent strain initiated by the linear expansion coefficient of the leadwire cable. Together these features minimize thermally-induced apparent strain, enabling highly accurate strain measurement.

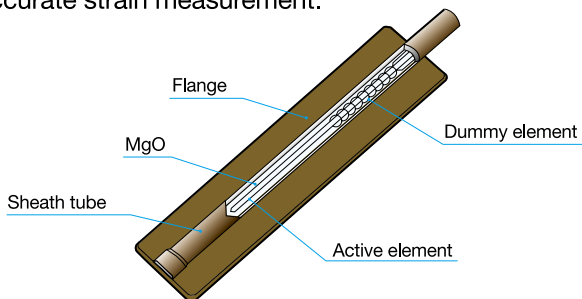

Applicable linear expansion coefficients of 11, 13 and 16 x10⁻⁶/°C are available standard. (11 and 13 x10⁻⁶/°C only for KHGX)

Models with other applicable linear expansion coefficients can be manufactured as desired by users. (Since the KHCV is designed for dynamic strain measurement only, it does not provide any temperature compensation.)

Substantial Test Data Sheet enables highly accurate strain measurement.

The Test Data Sheet accompanying each product describes temperature and zero (bridge balance) compensation resistance values. If the operating temperature range or the length of the heated portion of the MI cables are different from the ones shown in the graph below, contact us about the details. The estimated thermally-induced apparent strain and the gage factor change will be provided together with the graph. (Gage factor change is only for the KHCV)

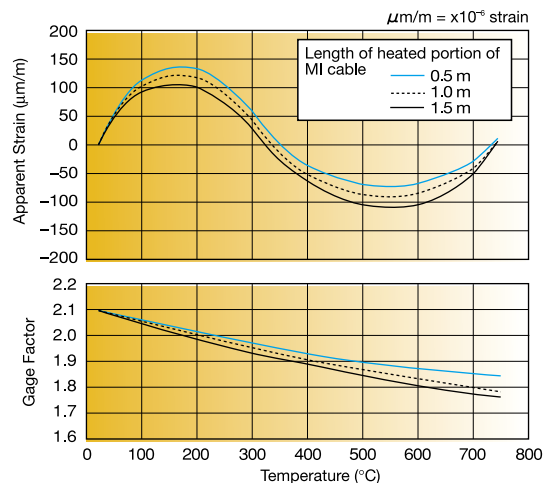

Estimated Thermally-induced Apparent Strain and Gage Factor Change

With the KHCV, gage factor is improved by approximately 50% over our forerunner previous model.

This is realized through improvement of the spot-welding method and adoption of a low-resistance MI cable. Also realized is the 120 Ω gage resistance in 5 mm gage length.

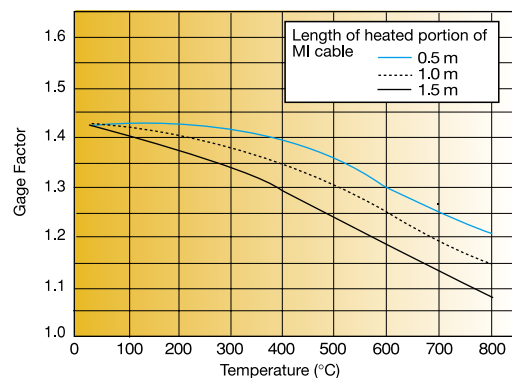

Thermally-induced Gage Factor Change

Models with bridge adapter option cut down on labor time and increase reliability.

The bridge adapter has the temperature compensation resistor wired (KHGX, KHCR, KHCS, KHCM, KHC). This not only eliminates the need for wiring the resistor to the bridge adapter but also facilitates connection to the measuring instrument.

Temperature Compensation Method and Bridge Circuit (KHGX, KHCR, KHCS, KHCM, KHC)

With foil strain gages, a half bridge configuration using active and dummy gage elements enables compensation of the output initiated by the temperature coefficient of the resistive material of the gage elements and the output initiated by the difference between the linear expansion coefficient of the gage elements and that of the measuring object.

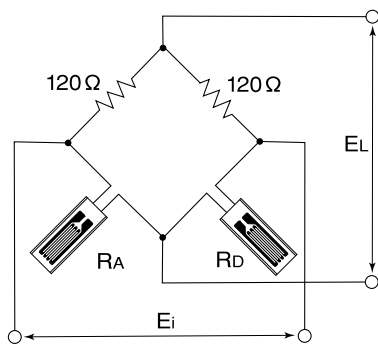

Temperature Compensation Circuit for Foil Strain Gage

In the case of encapsulated weldable strain gages, the dummy gage element has no sensitivity, disabling compensation of the output initiated by the difference between the linear expansion coefficient of the gage and that of the measuring object. This results in apparent strain–output corresponding to the difference between the linear expansion coefficient of the active gage element and that of the measuring object. To compensate the apparent strain, external temperature compensation resistors (RTC) are inserted to the bridge circuit. Furthermore, external temperature compensation resistors (RLC) are inserted to the bridge circuit to reduce the apparent strain initiated by the heated MI cable. The bridge balance broken by these resistors is corrected by balance adjustment resistors (RBAL). Each product is delivered with all of these resistors featuring the optimum values for the user's operating temperature range.

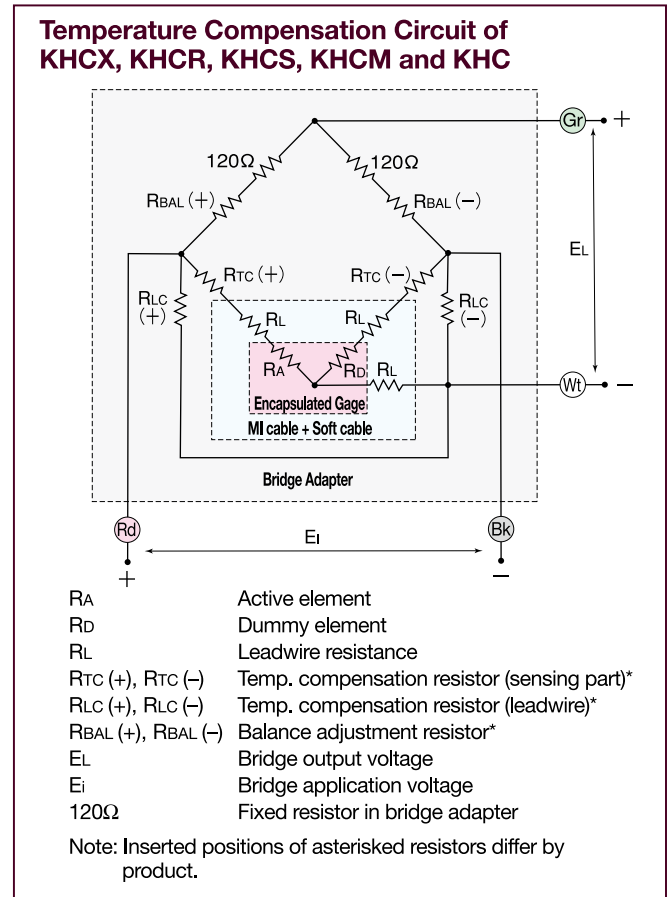

To facilitate configuration of the bridge circuit including these resistors, a bridge adapter is provided which will be pre-attached to the soft cable when delivered.

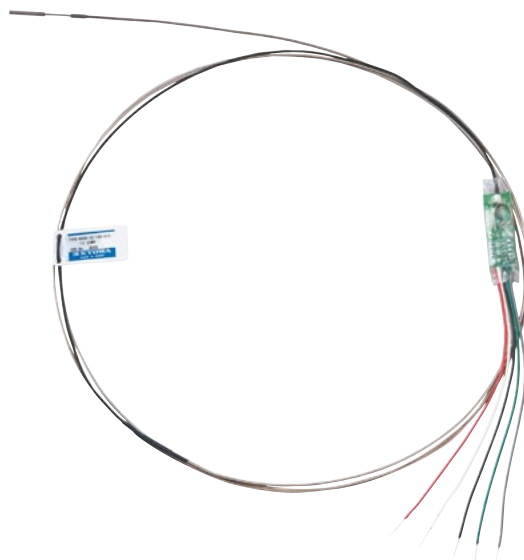

Normal-temperature Encapsulated Weldable Strain Gages

KCW
(Weldable Waterproof Foil Strain Gage)

Features

Weldable type ensures easy installation in the field.

The spot-welding method facilitates installation of gages to the measuring point. The sensing part is covered with stainless steel and requires no additional installation work such as coating. The cable-integrated structure also ensures easy handling.

Outstanding waterproof construction and long-term stability

The normal-temperature model can endure water pressure of approximately 10 MPa for 24 hours. Thus, it can safely be used outdoors, underwater or in highly humid environments.

Affordable

When compared with high-temperature models, the normal-temperature model is economically priced.

Structure & Circuit

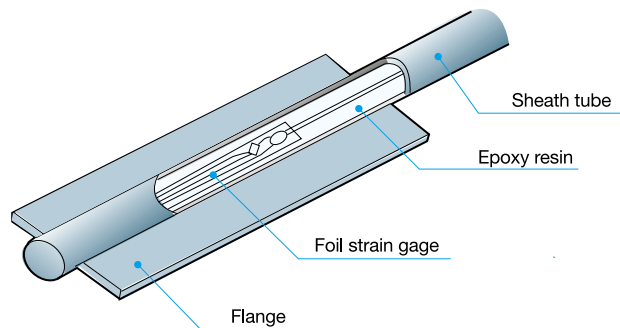
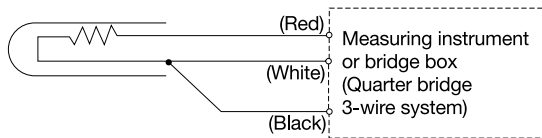

KHCX

Static/Dynamic Strain Measurement High-temperature Encapsulated Weldable Strain Gages

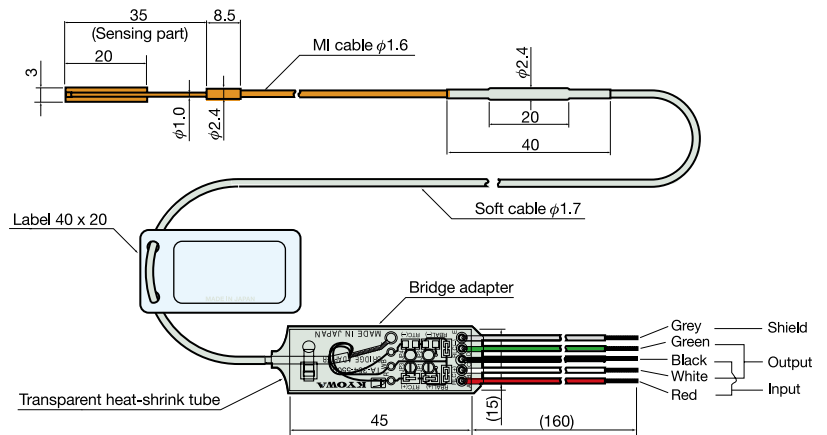

SPECIFICATIONS

Model	KHCX-10-120-G13-11 C2MV KHCX-10-120-G13-13 C2MV
Gage type	Uniaxial 2-element temperature-compensation type
Resistive element	Heat-resistant special alloy
Sensing part	Gage length: 10 mm Flange: 3 (W) x 20 (L) mm, t = 0.1 mm Sheath tube and flange: Inconel 600 (equivalent to JIS NCF600)
Gage resistance	Approx. 120 Ω
Leadwire cable	MI cable: Inconel 600-sheathed 3-Ni-conductor cable, 1.6 mm diameter by approx. 2 m long (std.) Soft cable: ETFE-coated 3-conductor shielded cable, 1.7 mm diameter by approx. 50 cm long
Max. operating temp.	Approx. 950°C
Appl. lin. exp. coef.	11, 13 x 10 ⁻⁶ /°C
Gage factor (sensing part only)	Approx. 1.7 at room temperature Approx. 1.5 at 950°C
Thermally-induced app. strain	The estimated curve is shown in the test data sheet.
Temp. comp. range	25° to 950°C
Operating temp. range	-196° to 950°C
Drift	Within ±20 μm/m/h (950°C)
Strain limit	±10000 μm/m at 950°C
Fatigue life	1 x 10 ⁶ times at 950°C (with strain level ±100 μm/m)
Max. allowable current	50 mA
Min. mountable curvature radius	75 mm (20 mm if the flange is fabricated before delivery)

• Model with no bridge adapter is also available.

Standard Accessories

- MI cable fixing metal belt (100 mm long, 2 pcs.)
- Weld test metal piece (30 mm long, 2 pcs.)
- Test Data Sheet
- Instruction Manual

The following resistors are additionally provided for models with no bridge adapter.

- Temperature-compensation resistor
- Bridge balance resistor

Optional Accessories

- Bridge adapter
- Spot welder GW-3C (refer to page 15)
- For bridge adapter, compression fitting and MI cable length, refer to pages 13 and 14.

Typical Applications

Grasping the physical properties of:

- High-temperature gas turbine blades
- Aircraft jet engine turbines
- Incinerators and heat treat furnaces
- Petrochemical reactors
- Heat-resistant alloys, etc.

950°C

Precautions

- In the case of models with the bridge adapter pre-attached, leadwires of the bridge adapter can be connected directly to a static strain measuring instrument such as UCAM-60B, but the leadwires should be connected to a dynamic strain measuring instrument such as EDX-100A via an optional input cable.
- Models with no bridge adapter pre-attached require an optional dedicated adapter.
- Study the features of high-temperature encapsulated weldable strain gages (page 2) and follow the instructions as described in "To Ensure Safe Usage of Encapsulated Weldable Strain Gages" (page 16).
- Mount the sensing part carefully so that the part may not receive any unreasonable force or may not be bent locally.
- It is recommended to use a measuring instrument of constant DC voltage application type such as UCAM-500B, CDV, etc.

KHCV

Dynamic Strain Measurement Only High-temperature Encapsulated Weldable Strain Gages

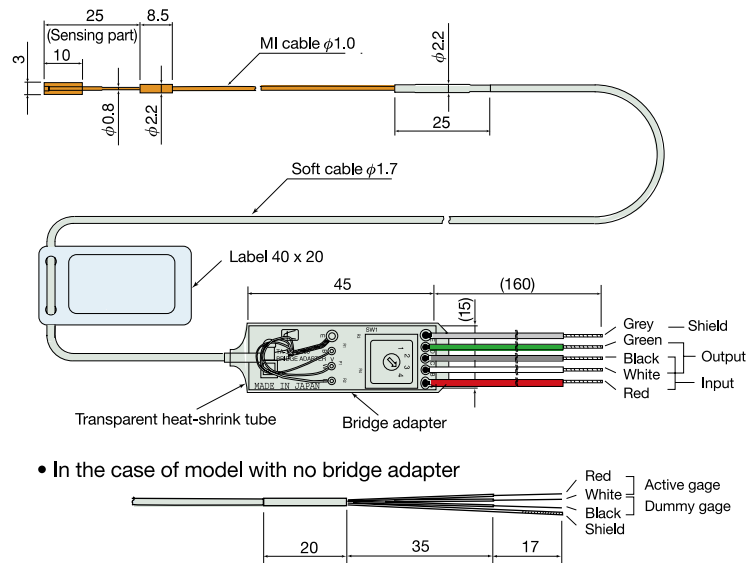

SPECIFICATIONS

Model	KHCV-5-120-G17 C2MV
Gage type	Uniaxial 1-element
Resistive element	Heat-resistant special alloy
Sensing part	Gage length: 5 mm Flange: 3(W) x 10(L) mm, t = 0.1 mm Sheath tube and flange: Inconel 600 (equivalent to JIS NCF600)
Gage resistance	Approx. 120 Ω
Leadwire cable	MI cable: Inconel 600-sheathed 3-Ni-conductor cable, 1.0 mm diameter by approx. 2 m long (std.) Soft cable: ETFE-coated 3-conductor shielded cable, 1.7 mm diameter by approx. 50 cm long
Max. operating temp.	Approx. 800°C (dynamic strain)
Gage factor (sensing part only)	Approx. 1.5 at room temperature Approx. 1.2 at 800°C
Operating temp. range	25° to 800°C
Strain limit	±10000 μm/m at 800°C
Fatigue life	1 × 10 ⁶ times at 800°C (with strain level ±500 μm/m)
Max. allowable current	50 mA
Min. mountable curvature radius	15 mm

• In the case of model with no bridge adapter, use the bridge box DB-120A or DB-120L.

Standard Accessories

- MI cable fixing metal belt (100 mm long, 2 pcs.)
- Weld test metal piece (30 mm long, 2 pcs.)
- Test Data Sheet
- Instruction Manual

The following are additionally provided for models with no bridge adapter.

- Capacitors (1, 2.2 and 10 μF)
- Resistor (10 kΩ)

Optional Accessories

- Bridge boxes DB-120A/L
- Bridge adapter
- Compression fitting
- Spot welder GW-3C (refer to page 15)
- For bride box, bridge adapter, compression fitting and MI cable length, refer to pages 13 and 14.

Typical Applications

Grasping the physical properties of:

- High-temperature gas turbine blades
- Aircraft jet engine turbines
- Incinerators and heat treat furnaces
- Petrochemical reactors
- Heat-resistant alloys, etc.

800°C

Precautions

- The KHCV is dedicated to dynamic strain measurement. Do not use it for static strain measurement.
- Use the DC-excited CDV signal conditioner as the measuring instrument.
- Study the features of high-temperature encapsulated weldable strain gages (page 2) and follow the instructions as described in "To Ensure Safe Usage of Encapsulated Weldable Strain Gages" (page 12).

KHCR

Static/Dynamic Strain Measurement High-temperature Encapsulated Weldable Strain Gages

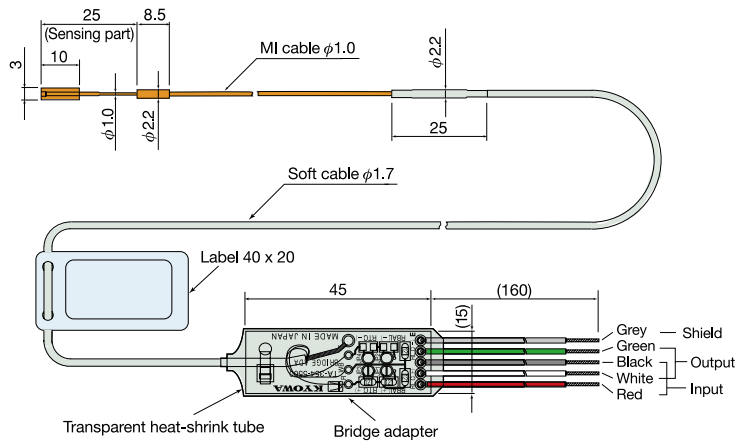

SPECIFICATIONS

Model	KHCR-5-120-G16-11 C2MV for common steel KHCR-5-120-G16-13 C2MV for Inconel 600 (equivalent to JIS NCF600) KHCR-5-120-G16-16 C2MV for stainless steel
Gage type	Uniaxial 2-element temperature-compensation type
Resistive element	Heat-resistant special alloy
Sensing part	Gage length: 5 mm Flange: 3(W) x 10(L) mm, t = 0.1 mm Sheath tube and flange: Inconel 600 (equivalent to JIS NCF600)
Gage resistance	Approx. 120 Ω
Leadwire cable	MI cable: Inconel 600-sheathed 3-Ni-conductor cable, 1.0 mm diameter by approx. 2 m long (std.) Soft cable: ETFE-coated 3-conductor shielded cable, 1.7 mm diameter by approx. 50 cm long
Max. operating temp.	Approx. 750°C
Appl. lin. exp. coef.	11, 13, 16 x 10 ⁻⁶ /°C
Gage factor (sensing part only)	Approx. 1.5 at room temperature Approx. 1.2 at 750°C
Thermally-induced app. strain	The estimated curve is shown in the test data sheet.
Temp. comp. range	25° to 750°C
Operating temp. range	25° to 750°C
Drift	Within ±20 μm/m/h (750°C)
Strain limit	±10000 μm/m at 750°C
Fatigue life	1 x 10 ⁶ times at 750°C (with strain level ±500 μm/m)
Max. allowable current	50 mA
Min. mountable curvature radius	15 mm

• Model with no bridge adapter is also available.

Standard Accessories

- MI cable fixing metal belt (100 mm long, 2 pcs.)
- Weld test metal piece (30 mm long, 2 pcs.)
- Test Data Sheet
- Instruction Manual

The following resistors are additionally provided for models with no bridge adapter.

- Temperature-compensation resistor
- Bridge balance resistor

Optional Accessories

- Bridge adapter
- Compression fitting
- Spot welder GW-3C (refer to page 15)
- For bridge box, bridge adapter, compression fitting and MI cable length, refer to pages 13 and 14.

Typical Applications

Grasping the physical properties of:

- High-temperature gas turbine blades
- Aircraft jet engine turbines
- Incinerators and heat treat furnaces
- Petrochemical reactors
- Heat-resistant alloys, etc.

750°C

Precautions

- In the case of models with the bridge adapter pre-attached, leadwires of the bridge adapter can be connected directly to a static strain measuring instrument such as UCAM-60B, but the leadwires should be connected to a dynamic strain measuring instrument such as EDX-100A via an optional input cable.
- Models with no bridge adapter pre-attached require an optional dedicated adapter.
- Study the features of high-temperature encapsulated weldable strain gages (page 2) and follow the instructions as described in "To Ensure Safe Usage of Encapsulated Weldable Strain Gages" (page 16).

KHCS

Static/Dynamic Strain Measurement High-temperature Encapsulated Weldable Strain Gages

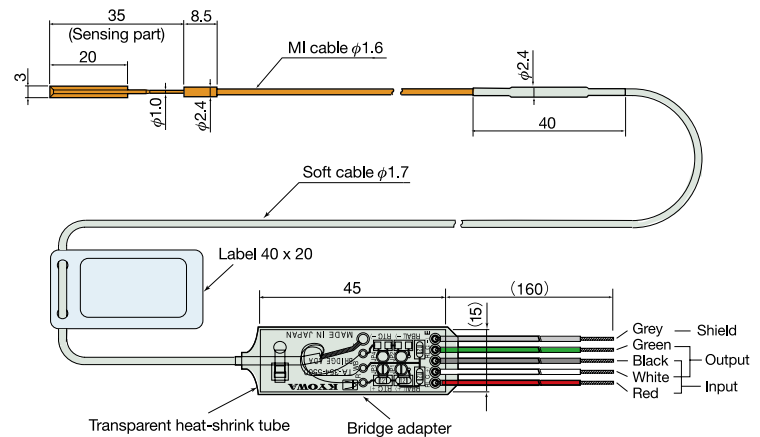

SPECIFICATIONS

Model	KHCS-10-120-G12-11 C2MV for common steel
	KHCS-10-120-G12-13 C2MV for Inconel 600 (equivalent to JIS NCF600)
	KHCS-10-120-G12-16 C2MV for stainless steel
Gage type	Uniaxial 2-element temperature-compensation type
Resistive element	Heat-resistant special alloy
Sensing part	Gage length: 10 mm
	Flange: 3(W) x 20(L) mm, t = 0.1 mm
	Sheath tube and flange: Inconel 600 (equivalent to JIS NCF600)
Gage resistance	Approx. 120 Ω
Leadwire cable	MI cable: Inconel 600-sheathed 3-Ni-conductor cable, 1.6 mm diameter by approx. 2 m long (std.)
	Soft cable: ETFE-coated 3-conductor shielded cable, 1.7 mm diameter by approx. 50 cm long
Max. operating temp.	Approx. 750°C for both static and dynamic strains
Appl. lin. exp. coef.	11, 13, 16 x 10 ⁻⁶ /°C or user-specified
Gage factor (sensing part only)	Approx. 2.0 at room temperature
	Approx. 1.8 at 750°C
Thermally-induced app. strain	The estimated curve is shown in the test data sheet.
Temp. comp. range	25° to 750°C
Operating temp. range	-196° to 750°C
Drift	Within ±20 μm/m/h (750°C)
Strain limit	±10000 μm/m at 750°C
Fatigue life	1 x 10 ⁶ times at 750°C (with strain level ±500 μm/m)
Max. allowable current	50 mA
Min. mountable curvature radius	20 mm

• Model with no bridge adapter is also available.

Standard Accessories

- MI cable fixing metal belt (100 mm long, 2 pcs.)
- Weld test metal piece (30 mm long, 2 pcs.)
- Test Data Sheet
- Instruction Manual

The following resistors are additionally provided for models with no bridge adapter.

- Temperature-compensation resistor
- Bridge balance resistor

Optional Accessories

- Bridge adapter
- Compression fitting
- Spot welder GW-3C (refer to page 15)
- For bridge adapter, compression fitting and MI cable length, refer to pages 13 and 14.

Typical Applications

Grasping the physical properties of:

- High-temperature gas turbine blades
- Aircraft jet engine turbines
- Incinerators and heat treat furnaces
- Petrochemical reactors
- Heat-resistant alloys, etc.

750°C

Precautions

- In the case of models with the bridge adapter pre-attached, leadwires of the bridge adapter can be connected directly to a static strain measuring instrument such as UCAM-60B, but the leadwires should be connected to a dynamic strain measuring instrument such as EDX-100A via an optional input cable.
- Models with no bridge adapter pre-attached require an optional dedicated adapter.
- Study the features of high-temperature encapsulated weldable strain gages (page 2) and follow the instructions as described in "To Ensure Safe Usage of Encapsulated Weldable Strain Gages" (page 16).

KHCM

Static/Dynamic Strain Measurement High-temperature Encapsulated Weldable Strain Gages

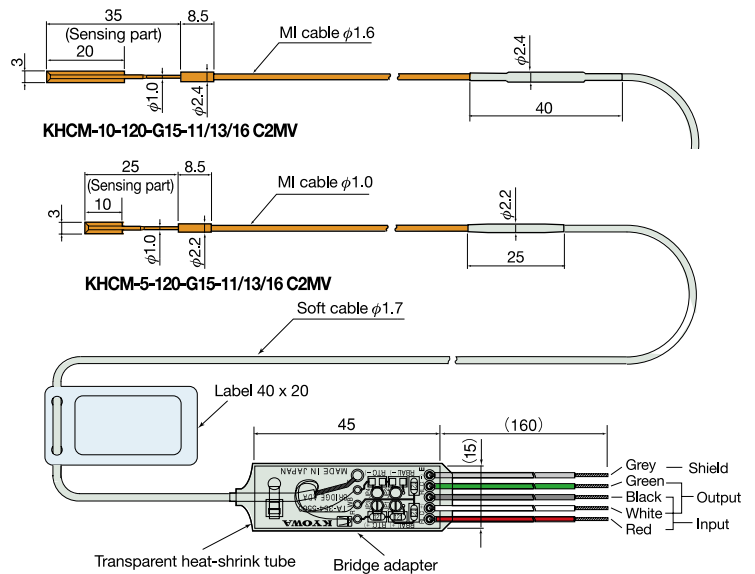

SPECIFICATIONS

	KHCM-10	KHCM-5
Model		
for common steel	KHCM-10-120-G15-11 C2MV	KHCM-5-120-G15-11 C2MV
for Inconel 600	KHCM-10-120-G15-13 C2MV	KHCM-5-120-G15-13 C2MV
for stainless steel	KHCM-10-120-G15-16 C2MV	KHCM-5-120-G15-16 C2MV
Gage type	Uniaxial 2-element temperature-compensation type	
Resistive element	Heat-resistant special alloy	
Sensing part		
Gage length	10 mm	5 mm
Flange	3(W) x 20(L) mm, t = 0.1 mm	3(W) x 10(L) mm, t = 0.1 mm
Material	Sheath tube and flange: Inconel 600 (equivalent to JIS NCF600)	
Gage resistance	Approx. 120 Ω	
Leadwire cable		
MI cable	1.6 mm by approx. 2 m long (std.)	1.0 mm by approx. 2 m long (std.)
	Inconel 600-sheathed 3-Cu-conductor cable	
Soft cable	ETFE-coated 3-conductor shielded cable, 1.7 mm diameter by approx. 50 cm long	
Max. operating temp.	Approx. 650°C for both static and dynamic strains	
Appl. lin. exp. coef.	11, 13, 16 x 10 ⁻⁶ /°C or user-specified	
Gage factor (sensing part only)		
	Approx. 2.0 at room temperature	Approx. 1.5 at room temperature
	Approx. 1.8 at 650°C	Approx. 1.4 at 650°C
Thermally-induced app. strain	The estimated curve is shown in the test data sheet.	
Temp. comp. range	25° to 650°C	
Operating temp. range	-196° to 650°C	
Drift	Within ±10 μm/m/h (650°C)	Within ±20 μm/m/h (650°C)
Strain limit	±10000 μm/m at 650°C	
Fatigue life	1 x 10 ⁶ times at 650°C (with strain level ±500 μm/m)	
Max. allowable current	50 mA	
Min. mountable curvature radius	20 mm	15 mm

• Model with no bridge adapter is also available.

650°C

Standard Accessories

- MI cable fixing metal belt (100 mm long, 2 pcs.)
- Weld test metal piece (30 mm long, 2 pcs.)
- Test Data Sheet
- Instruction Manual

The following resistors are additionally provided for models with no bridge adapter.

- Temperature-compensation resistor
- Bridge balance resistor

Optional Accessories

- Bridge adapter
- Compression fitting
- Spot welder GW-3C (refer to page 15)
- For bridge adapter, compression fitting and MI cable length, refer to pages 13 and 14.

Typical Applications

Grasping the physical properties of:

- Nuclear reactor peripherals
- Nuclear reactor cooling water pipes (sodium)
- High-speed bleeder reactors
- Automotive exhaust manifolds
- Automotive exhaust turbines, mufflers, valves, etc.

Precautions

- In the case of models with the bridge adapter pre-attached, leadwires of the bridge adapter can be connected directly to a static strain measuring instrument such as UCAM-60B, but the leadwires should be connected to a dynamic strain measuring instrument such as EDX-100A via an optional input cable.
- Models with no bridge adapter pre-attached require an optional dedicated adapter.
- Study the features of high-temperature encapsulated weldable strain gages (page 2) and follow the instructions as described in "To Ensure Safe Usage of Encapsulated Weldable Strain Gages" (page 16).

KHC

Static/Dynamic Strain Measurement High-temperature Encapsulated Weldable Strain Gages

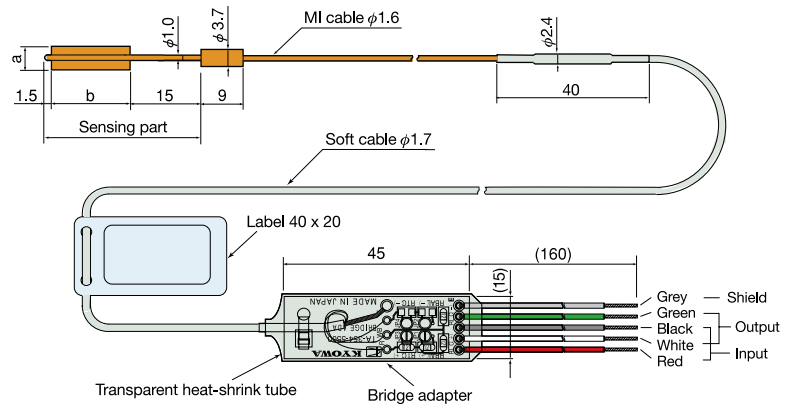

Type			Type		
	a	b		a	b
KHC-10-120-G8	4	16.5	KHC-20-120-G8	4	30
KHC-10-120-G9	5	16.5	KHC-20-120-G9	5	30

SPECIFICATIONS

		KHC-20	KHC-10
Model	for common steel	KHC-20-120-G8-11 C2MV KHC-20-120-G9-11 C2MV	KHC-10-120-G8-11 C2MV KHC-10-120-G9-11 C2MV
	for Inconel 600	KHC-20-120-G8-13 C2MV KHC-20-120-G9-13 C2MV	KHC-10-120-G8-13 C2MV KHC-10-120-G9-13 C2MV
	for stainless steel	KHC-20-120-G8-16 C2MV KHC-20-120-G9-16 C2MV	KHC-10-120-G8-16 C2MV KHC-10-120-G9-16 C2MV
Gage type		Uniaxial 2-element temperature-compensation type	
Resistive element		Heat-resistant special alloy	
Sensing part	Gage length	20 mm	10 mm
	Flange	For the width and length, see the dimensional drawing above; t = 0.1 mm	
Material		G8 type: Both sheath tube and flange are made of Inconel 600 (JIS NCF600). G9 type: Both sheath tube and flange are made of SUS 321.	
Gage resistance		Approx. 120 Ω	
Leadwire cable	MI cable	1.6 mm diameter by approx. 2 m long (std.), Inconel 600 (G8) or SUS 347 (G9)	
	Soft cable	ETFE-coated 3-conductor shielded cable, 1.7 mm diameter by approx. 50 cm long	
Max. operating temp.		Approx. 550°C (dynamic strain), approx. 500°C (static strain)	
Appl. lin. exp. coefficient		11, 13, 16 × 10 ⁻⁶ /°C or user-specified	
Gage factor (sensing part only)		Approx. 1.9 at room temperature	Approx. 1.65 at room temperature
		Approx. 1.75 at 500°C	Approx. 1.5 at 500°C
Thermally-induced app. strain		The estimated curve is shown in the test data sheet.	
Temp. compensation range		25° to 500°C	
Operating temp. range		-196° to 550°C (dynamic strain), -196° to 500°C (static strain)	
Drift		Within ±20 μm/m/h (500°C)	
Strain limit		±8000 μm/m at room temperature	±5000 μm/m at room temperature
Fatigue life		4 × 10 ⁵ times (with strain level ±1000 μm/m) at room temperature	
Max. allowable current		30 mA	
Min. mountable curvature radius		25 mm	20 mm

• Model with no bridge adapter is also available.

500°C / 550°C

Static Strain Dynamic Strain

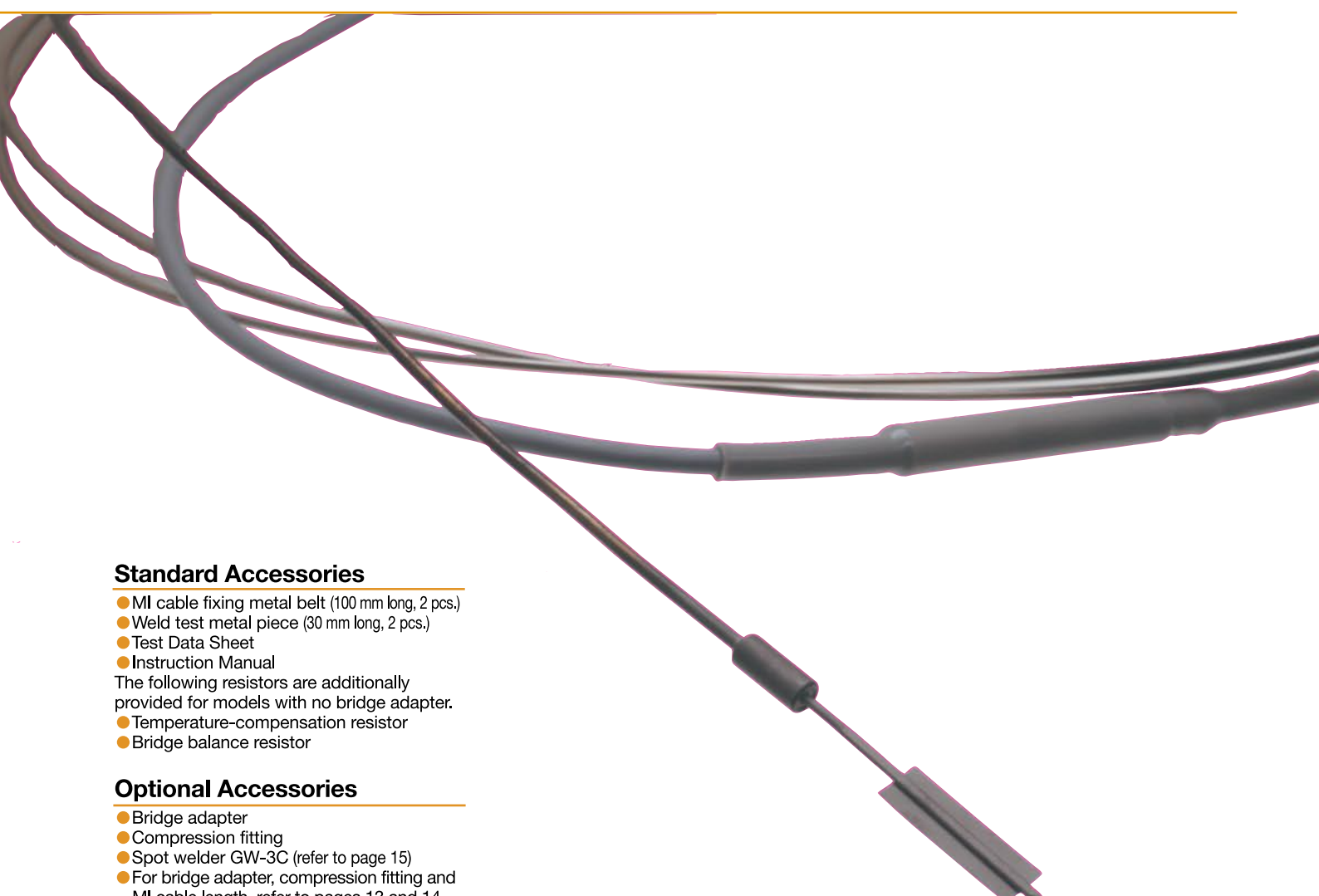

Standard Accessories

- MI cable fixing metal belt (100 mm long, 2 pcs.)
- Weld test metal piece (30 mm long, 2 pcs.)
- Test Data Sheet
- Instruction Manual

The following resistors are additionally provided for models with no bridge adapter.

- Temperature-compensation resistor
- Bridge balance resistor

Optional Accessories

- Bridge adapter
- Compression fitting
- Spot welder GW-3C (refer to page 15)
- For bridge adapter, compression fitting and MI cable length, refer to pages 13 and 14.

Typical Applications

Grasping the physical properties of:

- Nuclear fuel rods
- Boiler steam turbines
- Steelmaking furnace peripherals
- Automotive exhaust valves
- Nuclear power plant cooling pipes (pure water)
- Gas turbine combustors
- Automotive cylinder heads
- Automotive pistons
- Heat-resistant alloys, etc.

Precautions

- In the case of models with the bridge adapter pre-attached, leadwires of the bridge adapter can be connected directly to a static strain measuring instrument such as UCAM-60B, but the leadwires should be connected to a dynamic strain measuring instrument such as EDX-100A via an optional input cable.
- Models with no bridge adapter pre-attached require an optional dedicated adapter.
- Study the features of high-temperature encapsulated weldable strain gages (page 2) and follow the instructions as described in "To Ensure Safe Usage of Encapsulated Weldable Strain Gages" (page 16).

KCW

Static/Dynamic Strain Measurement Normal-temperature Encapsulated Weldable Strain Gages

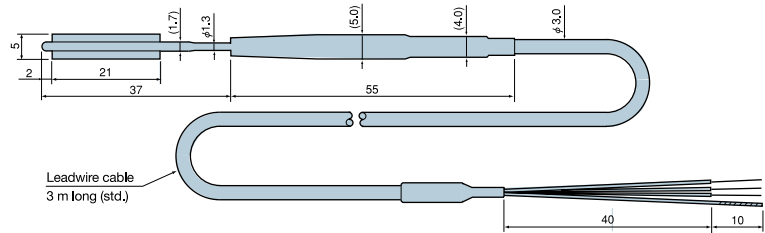

For measurement outdoors, underwater or under highly humid conditions

The normal-temperature KCW is a weldable waterproof foil strain gage encapsulated in a stainless steel tube. The integrated structure consists of a completely molded sensing part and a polyethylene-coated crosslink cable featuring excellent environmental capability. The sensing part can be spot-welded to the measuring point. Compared with high-temperature encapsulated weldable gages, the normal-temperature model is affordably priced.

SPECIFICATIONS

Model	KCW-5-120-G10-11 G3M3S, quarter bridge 3-wire system for common steel
Gage type	Uniaxial 1-element
Resistive element	NiCr alloy
Sensing part	Gage length: 5 mm Flange: 5(W) x 21(L) mm, t = 0.1 mm Sheath tube and flange: Stainless steel
Gage resistance	Approx. 120 Ω
Leadwire cable	Polyethylene-coated 3-conductor crosslink cable, 3 mm diameter by 3 m long (std.)
Max. operating temp.	Approx. 100°C for both static and dynamic strains
Appl. lin. exp. coef.	11 x 10 ⁻⁶ /°C
Gage factor	Approx. 2.2
Temp. comp. range	10° to 90°C
Operating temp. range	-20° to 100°C
Strain limit	±5000 μm/m
Fatigue life	1 x 10 ⁶ times (with strain level ±1000 μm/m)
Waterproof	Can endure approx. 10 MPa for 24 hours
Stability (Drift)	Within ±100 μm/m/500 h (80°C, 90% RH or higher, 1000 hours) Within ±40 μm/m/500 h (soaked condition, 1000 hours)
Min. mountable curvature radius	20 mm
Pcs./pack	2

Standard Accessories

- MI cable fixing metal belt (100 mm long, 4 pcs.)
- Weld test metal piece (30 mm long, 2 pcs.)
- Test Data Sheet
- Instruction Manual

Optional Accessories

- Bridge boxes DB-120A/L (refer to page 13)
- Spot welder GW-3C (refer to page 15)

Cable Lengths and Codes

Leadwire cable length	Code
15 cm	G15C3S
30 cm	G30C3S
50 cm	G50C3S
1 m	G1M3S
2 m	G2M3S
3 m (std.)	G3M3S
4 m	G4M3S
5 m	G5M3S
6 m	G6M3S
7 m	G7M3S
8 m	G8M3S
9 m	G9M3S
10 m	G10M3S
15 m	G15M3S
20 m	G20M3S
25 m	G25M3S
30 m	G30M3S

- When ordering, specify the model number together with the code of the desired cable length, suffixed with a space in between.
Example: KCW-5-120-G10-11 G5M3S for KCW with 5 m long polyethylene-coated crosslink 3-wire cable

Typical Applications:

- Thermal power plant boiler pumps
- Large-scale plant piping
- Underwater marine structures
- Underwater tests of mine reinforced structures
- Automotive suction blowers
- Car bodies

100°C

Precautions

- Study the features of high-temperature encapsulated weldable strain gages (page 2) and follow the instructions as described in "To Ensure Safe Usage of Encapsulated Weldable Strain Gages" (page 16).

For Connection to Measuring Instrument

Options

Bridge Boxes DB-120A/L

Designed to configure a Wheatstone bridge circuit with the KHCV or KCW connected.

● DB-120A

Cable: Chloroprene-coated, 5 m long, terminated with NDIS connector plug
 Dimensions: 60 x 42 x 25 mm
 Weight: Approx. 600 g (including cable)

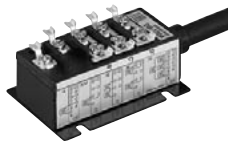

● DB-120L (Compact plug-in type)

Cable: Removable connection cable, 5 m long, terminated with NDIS connector plug
 Dimensions: 60 x 20 x 20 mm
 Weight: Approx. 60 g (main unit only)



KHCV Measuring Circuit

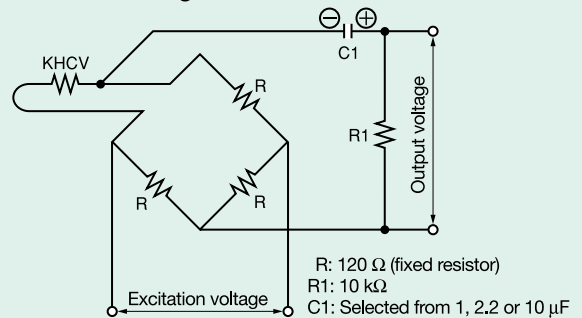

10 kΩ resistor and 1, 2.2 and 10 μF capacitors are included in standard accessories to KHCV.

Half Bridge Adapter

Equipped with optimum temperature compensation resistors for the operating temperature range. When delivered, it is pre-attached to the soft cable to prevent erroneous wiring and ensures labor saving.

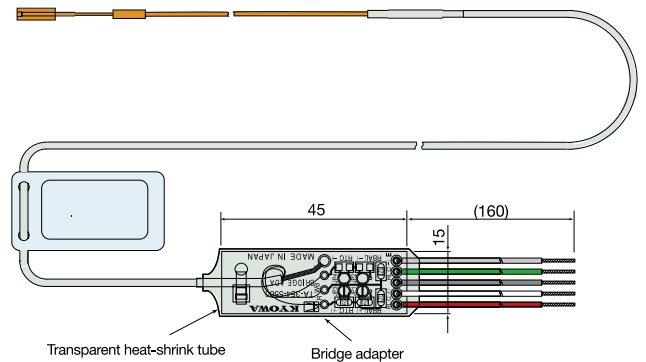
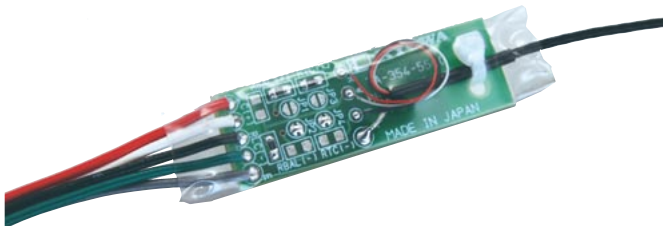

Quarter Bridge Adapter

Dedicated to the KHCV, this bridge adapter enables easy selection of the cutoff frequency (1.6, 7.23, 16 Hz or FLAT) as well as easy connection to the measuring instrument.

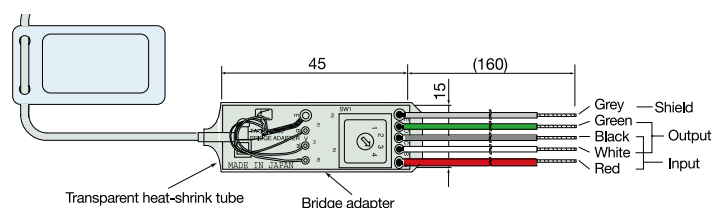
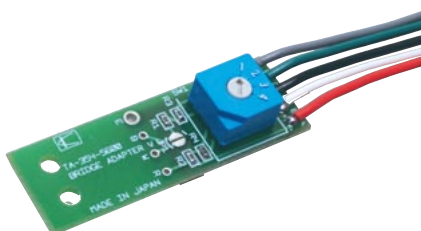

Compression Fitting

If required to fix the MI cable, the compression fitting is pre-attached to the MI cable at the factory. When ordering, specify the direction.

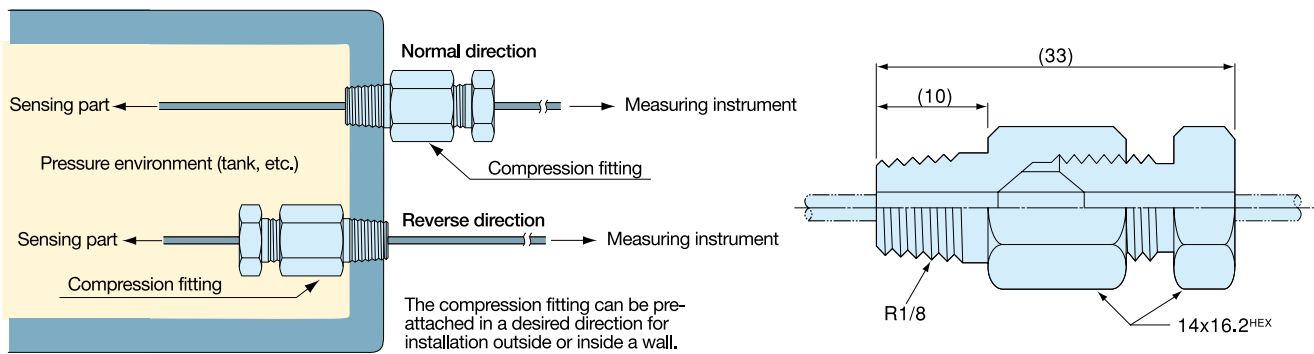

MI Cable Length Codes and Optional Accessories

When ordering, specify the model number together with the code of the desired MI cable length, suffixed with a space in between. The suffix may include codes of the optional bridge adapter and compression fitting (see table at the right). In all cases, the length of the soft cable is 50 cm (for extension, contact us).

Examples

- KHCS-10-120-G12-11 C5M
for KHCS with 5 m long MI cable
- KHCS-10-120-G12-11 C2MV
for KHCS with 2 m long MI cable and bridge adapter pre-attached

MI Cable Length	Code of MI Cable Length	Bridge Adapter Pre-attached ①	Compression Fitting Pre-attached ②	①+②
1 m	C1M	C1MV	C1MF	C1MFV
2 m (Std.)	C2M	C2MV	C2MF	C2MFV
3 m	C3M	C3MV	C3MF	C3MFV
4 m	C4M	C4MV	C4MF	C4MFV
5 m	C5M	C5MV	C5MF	C5MFV
6 m	C6M	C6MV	C6MF	C6MFV
8 m	C8M	C8MV	C8MF	C8MFV
10 m	C10M	C10MV	C10MF	C10MFV

GW-3C

Compact Spot Welder for Encapsulated Weldable Strain Gages



Features

- Welding current output is suitable for stainless steel, enabling welding of 0.3 mm thick stainless steel sheets.
- The electrode is 1 mm diameter at both ends.
- To enable optimum welding, energy is switchable between high and low ranges and is continuously variable in each range.
- An aluminum trunk is optionally available for transportation and storage.

SPECIFICATIONS

Welding energy (COARSE)	LOW	0 to 25 W·s, continuously variable (FINE 0 to 10)
	HIGH	0 to 50 W·s, continuously variable (FINE 0 to 10)
Welding speed	1 W·s	150 times/minute
	5 W·s	120 times/minute
	10 W·s	80 times/minute
	20 W·s	60 times/minute
	50 W·s	30 times/minute
Operating temp. & humidity ranges	0° to 40°C, 85% RH or less	
Storage temperature range	-10° to 60°C	
Power supply	AC line, 50/60 Hz, 500 VA or less	
Dimensions	183(W) x 153(H) x 313(D) mm (excluding protrusions)	
Weight	Approx. 8.2 kg (mainframe)	

DIMENSIONS

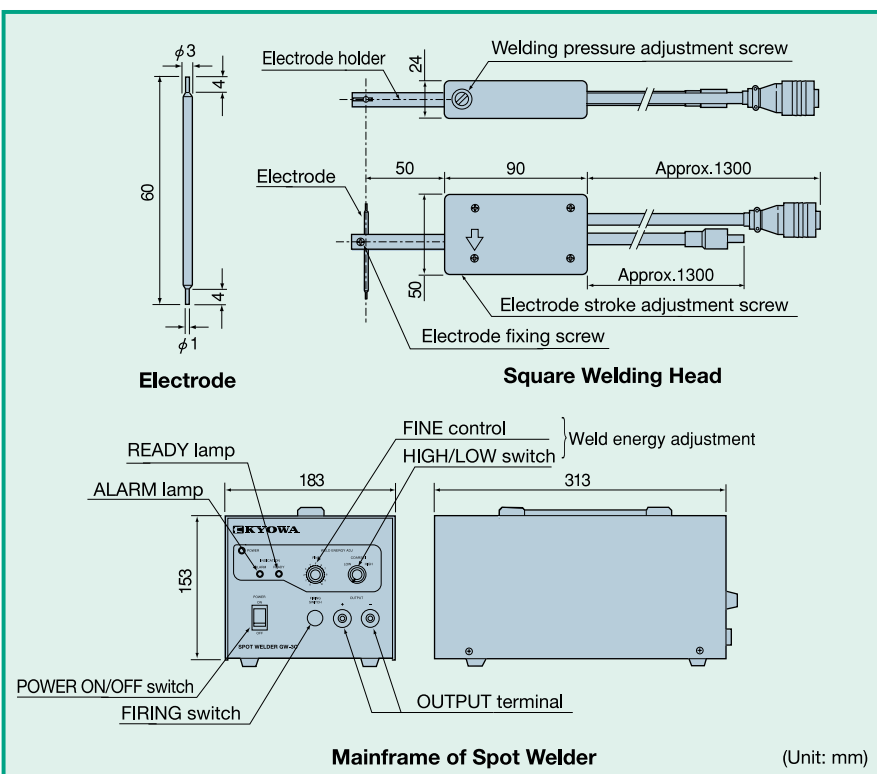

Standard Accessories

- Square welding head (with cable approx. 1.3 m long)
- Grounding clip (with cable approx. 1.3 m long)
- Electrode GW-02
- Metal file
- Fuse (5 A)
- Hexagon wrench
- Instruction Manual

Optional Accessories

- Aluminum trunk GW-01

Precaution

Follow the instructions as described in "To Ensure Safe Usage of Encapsulated Weldable Strain Gages" (page 16).

Stainless Steel Sheet Thickness and FINE Control Setting Reference Values

Stainless Steel Sheet Thickness (mm)	COARSE Range		Welding Energy (W·s)
	LOW	HIGH	
0.1	2	1	5
0.2	6	3	15
0.3	—	6	30

Welding Capability

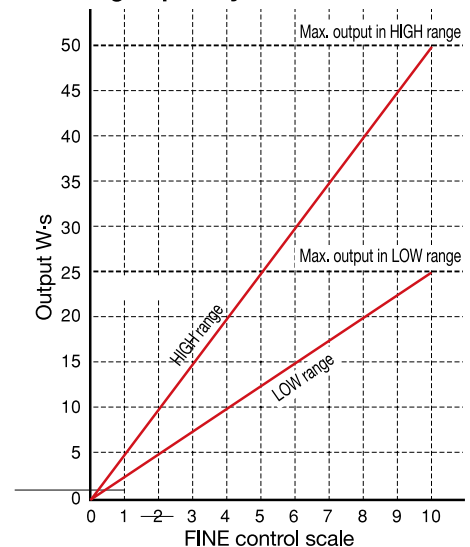

Precaution: It is not possible to perform welding for a continuous 4 minutes or longer at 1-second intervals with FINE control set at 5 in HIGH range or for a continuous 10 minutes or longer at 1-second intervals with FINE control set at 10 in LOW range.

To Ensure Safe Usage of Encapsulated Weldable Strain Gages

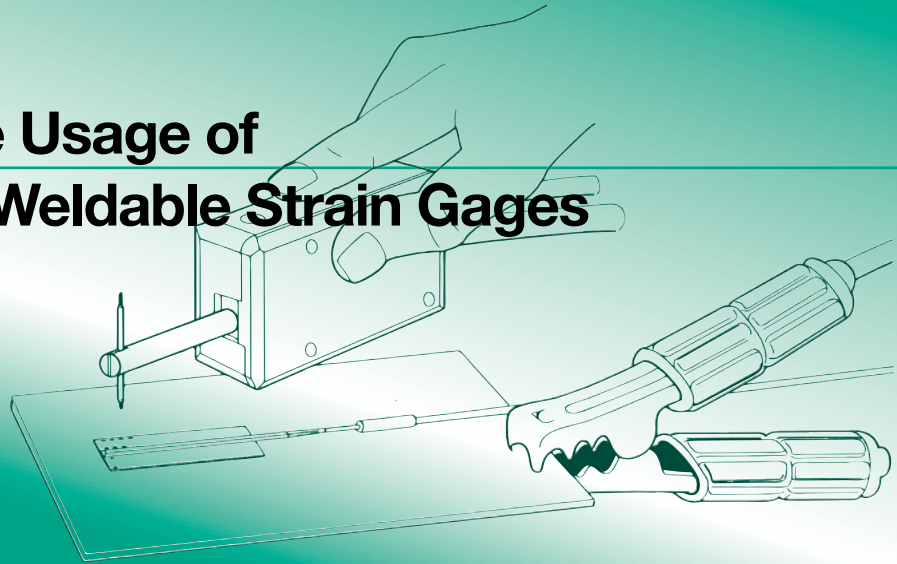

- Be sure to read the instruction manual before use.
- Encapsulated weldable strain gages are designed to be mounted to the measuring object by spot-welding. Thus, they can be mounted to ferrous materials but not to aluminum, copper, ceramic or the like.
- Surface treatment: Remove rust and paint from the surface of the measuring point by polishing with sandpaper (#320, etc.). Wipe away dirt and oil with a solvent such as acetone. While the flange is cleaned by sand-blasting at the factory, degrease it with acetone or the like as required.
- Be sure not to cut the MI cable or make any hole on it. The insulating material filled in the cable may absorb moisture through a hole, thereby disabling measurement.
- To prevent the sensing part from any damage due to tension or twisting caused by the weight or handling of the MI cable, fix the connection between the sensing part and MI cable, and the MI cable at proper intervals using accessory metal belts. Then, spot-weld the flange. (Fig. 1)

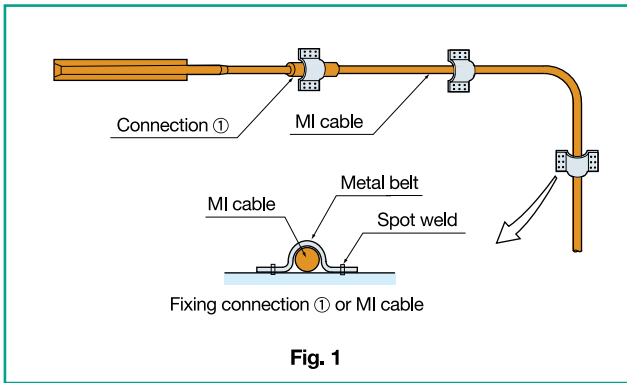

Fig. 1

- Spot-welding the flange: It is recommended to use KYOWA GW-3C spot welder (see page 15). At first, temporarily fix the center of the flange at the left and right. Then, spot-weld the flange in the order shown below. Standard welding conditions are: tip of electrode 0.8 mm diameter, welding energy approx. 10 W-s and electrode pressing force approx. 10 N.

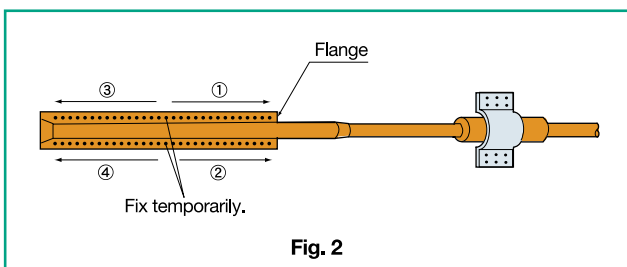

Fig. 2

Note:

In the case of KHCV, KHCR or KHCM-5, spot-weld the tip at the center too. (Fig. 3)

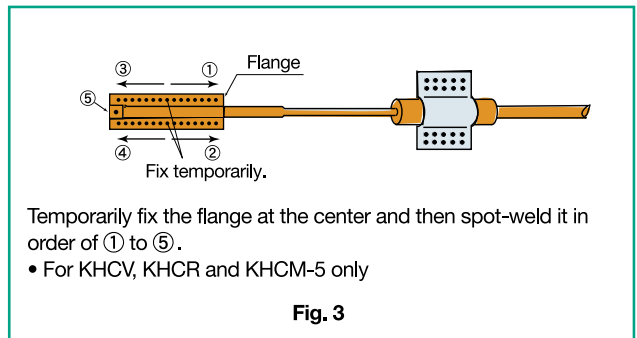

Fig. 3

- For KHCV, KHCR and KHCM-5 only
- Spot-welding the flange to a curved surface: Press the flange against a pipe or the like having the same curvature as the mounting surface so that the flange is given the same curvature as the mounting surface. Then, spot-weld. (Fig. 4) If the curvature radius and curved direction are specified when ordering, the gage will be delivered with the specified shape.

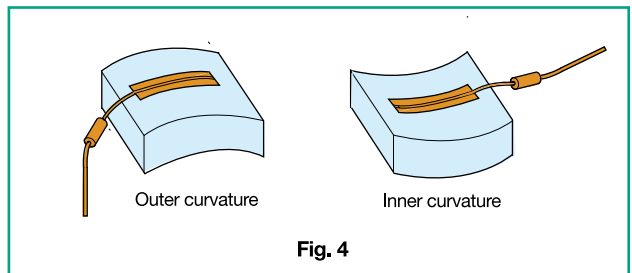

Fig. 4

- For the temperature compensation method, refer to "Temperature Compensation Method and Bridge Circuit (KHCV, KHCR, KHCS, KHCM, KHC)," page 3.

Fill in the form below when inquiring or ordering.

Company/Institute Name		
Address		
Section/Department		
Name		
Phone	Fax	E-mail

(1) Measurement purpose	
(2) Type of strain	<input type="checkbox"/> Static strain <input type="checkbox"/> Dynamic strain (Hz)
(3) Strain quantity	<input type="checkbox"/> Approx. $\mu\text{m/m}$ <input type="checkbox"/> Unclear
(4) Operating temperature range	<input type="checkbox"/> to $^{\circ}\text{C}$, number of cycles: <input type="checkbox"/> to $^{\circ}\text{C}$, hours: h
(5) Length of high-temp. exposed cable	<input type="checkbox"/> m, required length of MI cable: m
(6) Length of room-temp. exposed cable	<input type="checkbox"/> m, required length of soft cable: m
(7) Environment	<input type="checkbox"/> e.g. gaseous atmosphere, under seawater, etc.
(8) Removing from pressure vessel, etc.	<input type="checkbox"/> Yes <input type="checkbox"/> No <input type="checkbox"/> Compression fitting pre-attached model is desired. Direction: <input type="checkbox"/> Inside <input type="checkbox"/> Outside
(9) Measuring object material	<input type="checkbox"/> (In the case of special material, write the composition.)
(10) Requirements for heat treatment of measuring object	<input type="checkbox"/>
(11) Linear expansion coefficient of measuring object	<input type="checkbox"/> If it can be shown in an equation: Function (approximate value) related with temperature T Equation: $f(T) =$ <input type="checkbox"/> At room temperature $^{\circ}\text{C}$ ($\times 10^{-6}/^{\circ}\text{C}$) <input type="checkbox"/> At high temperature $^{\circ}\text{C}$ ($\times 10^{-6}/^{\circ}\text{C}$) <input type="checkbox"/> Unclear
(12) Mounting space	<input type="checkbox"/> x mm
(13) Curvature of mounting surface	<input type="checkbox"/> Flat <input type="checkbox"/> Inside of R mm <input type="checkbox"/> Outside of R mm
(14) Desired gage length	<input type="checkbox"/> 5 mm <input type="checkbox"/> 10 mm <input type="checkbox"/> 20 mm <input type="checkbox"/> None
(15) Desired model	<input type="checkbox"/>
(16) Adapter	<input type="checkbox"/> Bridge adapter pre-attached model is desired.
(17) Estimated apparent strain and gage factor	<input type="checkbox"/> Wish to have the Test Data Sheet accompanying the estimated data (gage factor only for KHCV). <input type="checkbox"/> Wish to have the actual measurement data.
(18) Measuring system	<input type="checkbox"/> Encapsulated gage <input type="checkbox"/> Bridge adapter (Amplifier) (Logger)
(19) Spot welder	<input type="checkbox"/> Possess <input type="checkbox"/> Wish to purchase <input type="checkbox"/> Wish to rent
(20) KYOWA representative	

www.kyowa-ei.com

Specifications are subject to change without notice for improvement.



Safety precautions

Be sure to observe the safety precautions given in the instruction manual in order to ensure correct and safe operation.



JQA-0821
JQA-EM4824

Move into the future with reliable measurements



KYOWA ELECTRONIC INSTRUMENTS CO., LTD.

Overseas Department:

3-5-1, Chofugaoka, Chofu, Tokyo 182-8520, Japan
Phone:+81-42-489-7220 Facsimile:+81-42-488-1122
<http://www.kyowa-ei.com>
e-mail: overseas@kyowa-ei.co.jp

Cat. No. 917C E1-2

Manufacturer's Distributor



KVALITEST
— INDUSTRIAL —

Printed in Japan July 2014