



Smart Sensing Solutions Since 1954

SMARTEYE® COLORWISE™ TRUE COLOR SENSOR



True Color Sensor
with Analog and Digital Outputs



SMARTEYE® COLORWISE™ TRUE COLOR SENSOR

The **SMARTEYE® COLORWISE™ True Color Sensor** is the most feature packed color sensor available. Designed to work as well as a spectrometer, this sensor can solve the most difficult color applications at higher speeds than color cameras or the closest priced competitive product. The 4-Channel monitor provides a visual confirmation of performance without having to switch channel selections or touch the sensor in any way. Providing a choice in speed versus resolution, the **SMARTEYE® COLORWISE™** puts the controls of the performance of the sensor in the hands of the operator; allowing for more application solutions, and removing the limits that either speed or resolution alone can offer.

With control over tolerance, light intensity, output configuration (NPN or PNP), timers, input configuration (edge or gate), the **SMARTEYE® COLORWISE™** provides a tailored and customized solution for the most difficult color sorting or inspection problems facing today's packaging and production lines. The **SMARTEYE® COLORWISE™** also comes equipped with four digital and three analog outputs that not only help to sort products by color, but can determine specific color signatures as well.

The **SMARTEYE® COLORWISE™ True Color Sensor** from Tri-Tronics®: *The Wisest choice you can make!*



Features

- Four digital outputs (NPN or PNP)
- 4-Channel monitor for at-a-glance performance evaluation
- Three analog outputs (XYZ or xyY); 0 to 5VDC
- Adjustable tolerance for each channel
- Adjustable timers for each channel: One Shot; On Delay; Off Delay; Latch
- 14-Pin 6in (152.4mm) pigtail 1/4-turn locking connector or cable version
- Adjustable LED light intensity
- Select high speed versus high resolution (CW-1 model only)
- Short range and long range models
- Remote color capture
- Button lockout

Benefits

- Flexible and convertible for many different color applications.
- Useful for color sorting and color verification applications all in one sensor.
- No-touch setup via remote color capture wire (selectable input; NPN/Negative or PNP/Positive).
- Reduce cost and speed constraints of color cameras or spectrometers.
- Quick digital changeover.
- Tamperproof with button lockout feature.

Applications

- Automotive - trim color assembly, carpet and mat matching, paint verification
- Textile - color verification, die quality control
- Bottle industry - color sorting, color verification, quality inspection
- Food industry - cooking time control, quality inspection/control
- Graphic art - color verification, quality control, missing color detection

Applications



Color Sorting

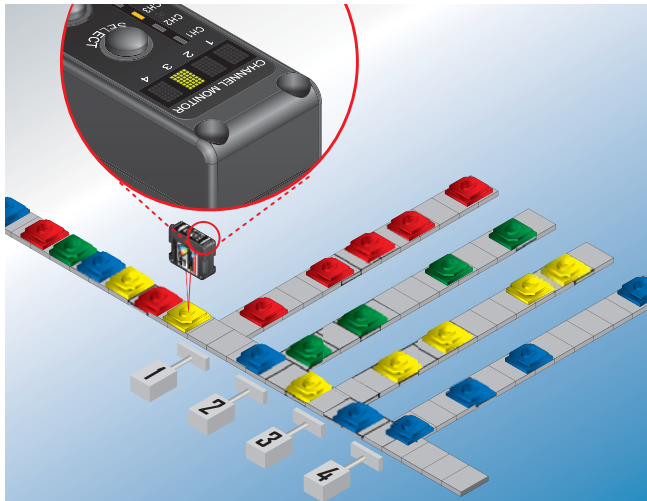

Sort items by color.

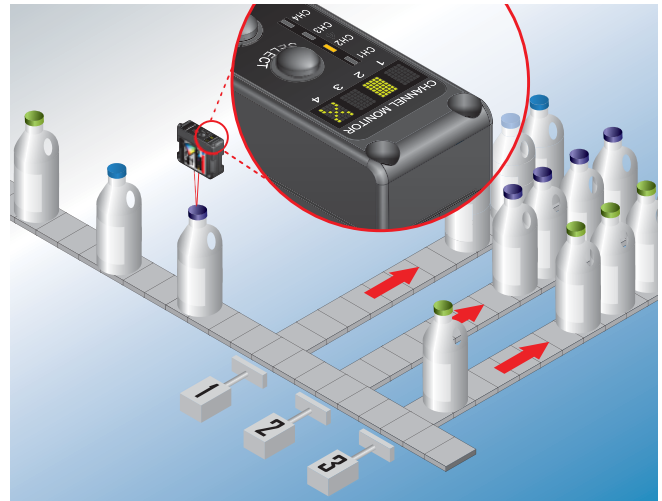

Separate grouped items by color.

Color Verification for Quality Inspection

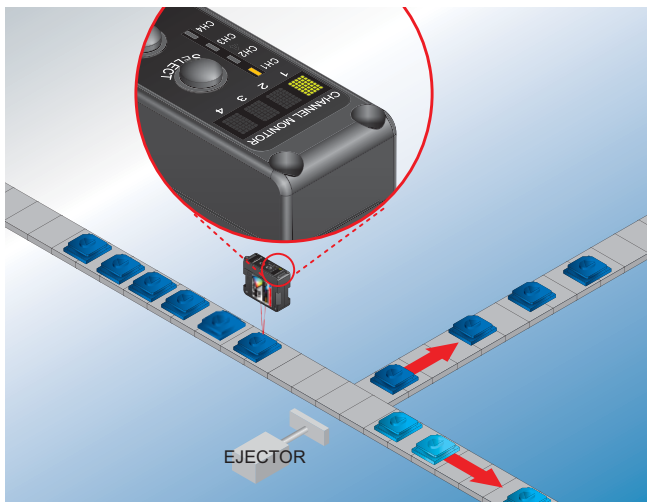

Verify proper shade of color.

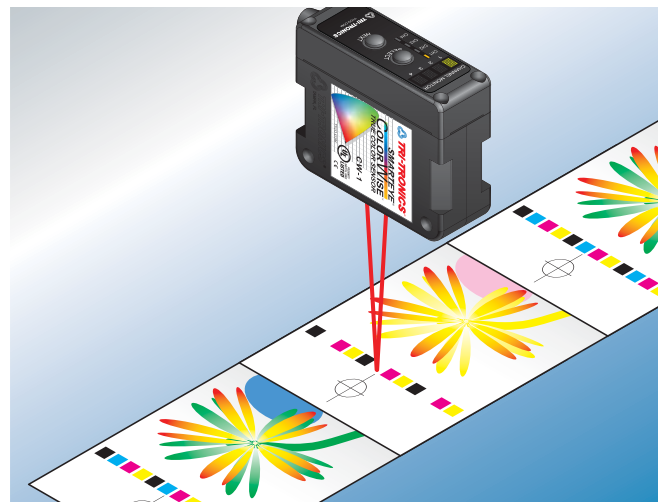

Inspect for missing colors.

Color Process Control



Guarantee uniform cooking for efficient process.



Control energy usage via color process control.

Features



Color Capture (CAPT)

Setup on target color with a simple push of a button. Four individual digital channels.

Four Channel Color Monitor (CH-X)

At-a-glance visual confirmation of real time performance for all four channels. Bargraph indicates quality of color match on each channel.

Tolerance Adjustment

Precise adjustment of tolerance levels for each of the four channels provides a wide range of resolution capabilities.

Color (C) or Color + Intensity (CI)

The ability to select between color and color + intensity provides the ability to differentiate between slight color differences, or shade-to-shade changes.

Output Mode

Select LO for output ON for a color match; DO for output OFF for no color match; and MUTE to de-select channel monitor and disable output.

Speed versus Resolution

Select Uspd - Ultra High Speed (75µs); HSpd - High Speed (150µs); or HRes -high resolution (300µs).
Note: This feature available on CW-1 models only.

Light Intensity

Adjust light intensity (L100) in System Parameter from L10, dimmest to L100, brightest. Useful when mechanical restrictions limit sensor position or distance.

Timer

Timer available for each of the four channels: Toff = No Timer; OffD = Off Delay; OnD = On Delay; Shot = One Shot; Ltch = Latch. Adjustable from 1ms to 9999ms.

Remote Capture

Pulse the Remote Capture wire to negative or positive, dependent upon the IN> setting, NPN or PNP, respectively.
Note: Each pulse on for 40ms to 400ms. The time between pulses is 40ms to 400ms.

Signal Strength Monitor

Displays the total signal strength as a number from 0 (low) to 100 (high). Useful in determining when too much or too little light is being received. Useful for setup in determining sensor position.

Input (Gate or Edge)

Provides a window of time to detect/capture the target color, allowing for inspection of color at the proper space and time during continuous product flow and normal production line speeds.

Connections

Available with standard 6ft (1.8m), 14-wire cable; or optional 6in (152.4mm) pigtail, 14-pin, 1/4-turn locking connector. Mating cable model #BCC-6.

Mounting Options

Through-hole or available bracket mounting.

The diagram shows the front panel of the SMARTEYE ColorWise sensor. It features a 'CHANNEL MONITOR' section with four bargraphs labeled 1, 2, 3, and 4. Below these are four LEDs labeled CH1, CH2, CH3, and CH4. There are two push buttons labeled 'SELECT' and 'NEXT'. The 'TRI-TRONICS TCO.COM' logo is at the bottom. Red callout lines point from the text on the right to the corresponding features on the panel.

ALPHANUMERIC DISPLAY

- 4-Channel Color Monitor for at-a-glance performance feedback.
- Alphanumeric display of available options.

OUTPUT INDICATORS

LED's for CH1 through CH4 ON when outputs are ON.

SELECT

- Select sub menu.
- Initiate color capture.
- Alter system parameters.
- Alter numeric values.
- Change from Channel Monitor to Signal Strength display.

NEXT

Advance through menu options.

Note: If any output indicators (CH1 - CH4) blink, output is shorted or overloaded.

Special Features

Analog XYZ and xyY

The ColorWise has three analog output wires that operate together in one of two modes, XYZ or xyY, as set in the System Parameters menu. In the XYZ mode the sensor provides an RGB type output. The X, Y, and Z output wires represent the intensity of the red, green, and blue components of the target color as a 0-5VDC signal. In the xyY mode the sensor provides an output that separates color from intensity. The x and y signals act as (x,y) coordinates to give an indication of color while the magnitude of the Y signal gives an indication of signal intensity or color brightness. Output signals in xyY mode are also given as 0-5VDC on each wire.

The ColorWise analog outputs can easily be evaluated by a PLC for use in process control, inspection, sorting, and other applications.

For more information on the XYZ and xyY Color Space and definitions, go to:

http://www.optics.arizona.edu/opti588/reading/CIE_color_space.pdf

Gate Input

The Gate input wire can be used with or without the Latch Timer function. Useful for resetting the latch, gating or triggering the sensor at a specific time and location on the target, and for windowing the sensor to ignore other targets or objects that may come into view which should be ignored. The Input can be configured for either an NPN/Negative, or a PNP/Positive signal.

GATE INPUT FUNCTIONALITY - LATCH DISABLED

GATE MODE OR EDGE MODE SET IN SYSTEM MENU

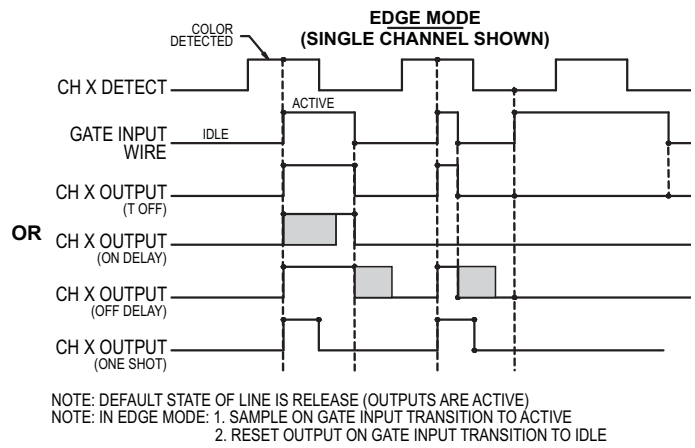
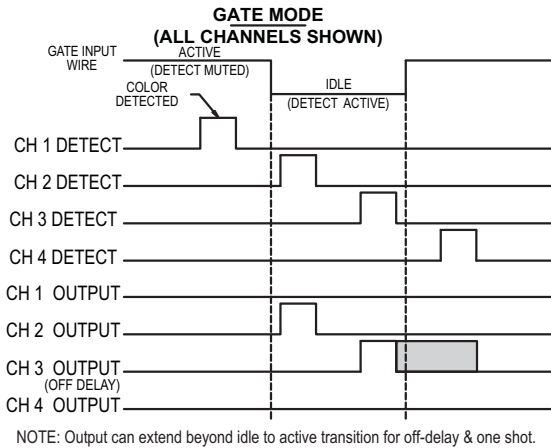

GATE INPUT FUNCTIONALITY - LATCH ENABLED

GATE MODE OR EDGE MODE SET IN SYSTEM MENU

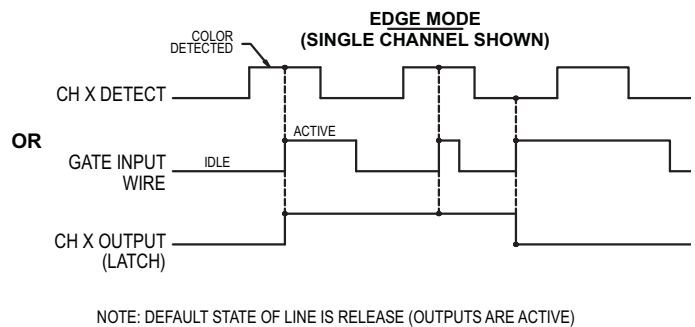
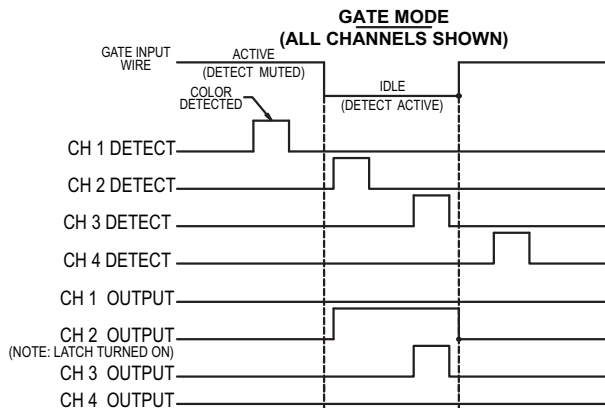

Remote Capture

Pulse the Remote Capture wire to negative or positive, dependent upon IN> setting; NPN or PNP, respectively.

NOTE: Each pulse on for 40ms to 400ms. The idle time between pulses is 40ms to 400ms

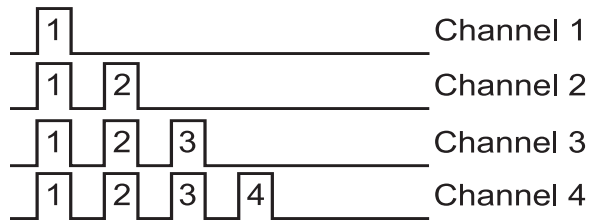

ColorWise Range Guideline

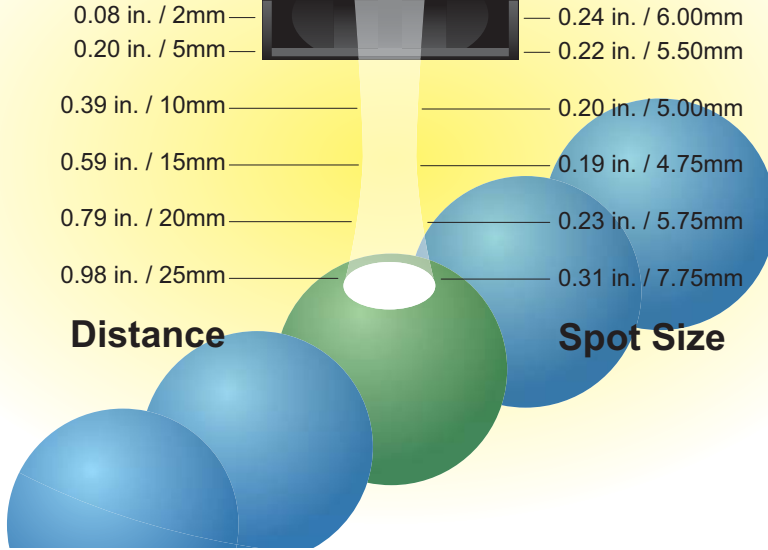

Short Range Guideline (CW-1/CW-1S)

The short range version is useful when the color is consistent across the entire product, when product is small, when the target is a color registration mark, or when the target is a specific color on a label. Applications that may be solved with the short range models are cap color, registration marks, label orientation, pharmaceutical color coding, tote sorting, etc.

The short range version allows for a selection of speed versus resolution to resolve high speed color applications as well as low levels of color shade changes.

Long Range Guideline (CW-2)

The long range models should be used when distance to the target exceeds the range of the short range model, the physical or mechanical constraints require a longer range, or the product needs a larger spot of light for averaging as in applications such as textile, food, or grainy products or surfaces.

The long range model provides a wide range of focal distances, with a large beam to view over surfaces that require more color averaging over many different substrate surface textures.

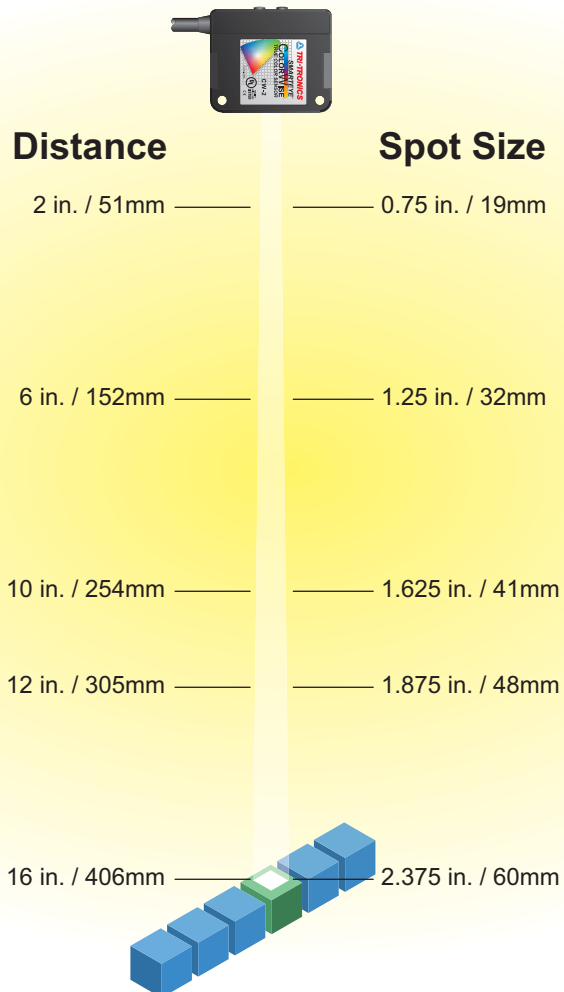

How to Specify

1. **Select Sensor:**
SMARTEYE® ColorWise™ True Color Sensor
2. **Select Connection:**
Blank = 6(1.8m), 14 conductor, 28AWG Cable
C = 6in (152mm) pigtail with 14-pin, 1/4-turn locking connector
3. **Select Model:**
-1 = Short Range
-1S = Short Range Single Channel
-2 = Long Range
4. **Select Lens Material:**
Blank = Acrylic
G = Glass

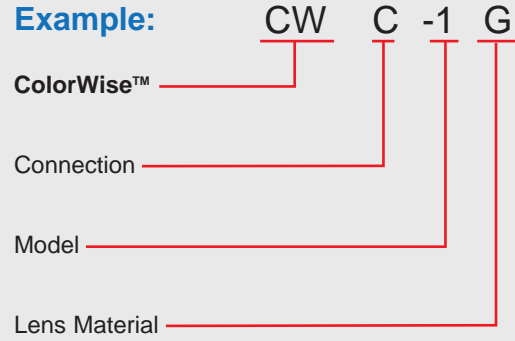

Hardware & Accessories

Extension Cable and Bracket Selection Guide

Standard ColorWise Cable



BCC-6
6ft (1.8m), 14-pin, twist-lock connector cable

Single Channel ColorWise Cable



GSEC-6
6ft (1.8m) cable

GSEC-15
15ft (4.6m) cable

GSEC-25
25ft (7.62m) cable



GRSEC-6
6ft (1.8m) right angle

GRSEC-15
15ft (4.6m) right angle

GRSEC-25
25ft (7.6m) right angle

Mounting Brackets



XMB-1L
Left



XMB-1R
Right



XMB-2
Front Mount



SEB-4
Stainless Steel
Mounting Bracket

Specifications



SUPPLY VOLTAGE

- 12 to 24VDC
- Polarity protected
- Intended for use in Class 2 circuits

CURRENT REQUIREMENTS

- CW-1/CW-1S: 110mA@12VDC, 80mA@24VDC
- CW-2: 140mA@12VDC, 85mA@24VDC

PERFORMANCE

- CW-1/CW-1S: Effective Resolution: Min. 12 bit, Max. 16 bit
- CW-2: Effective Resolution: 14 bit

OPTICAL CHARACTERISTICS

- Light emitter: white LED
- Optical axis: CW-1/CW-1S: coaxial; CW-2: convergent
- Receiving spectrum: 400nm to 700nm

DIGITAL OUTPUTS

- Four (4) selectable NPN or PNP open collector outputs
- 75mA capacity
- Short circuit & transient voltage protected
- Residual voltage: NPN, 1.35 max.; PNP, 2.05 max.

ANALOG OUTPUTS

- Three outputs: selectable as XYZ for color differentiation (RGB equivalent) or xyY for color + intensity differentiation
- 0-5VDC +/-1%
- 10 bit resolution
- Max load per channel: 2k OHMS
- Transient suppression

OUTPUT SELECTION

- LO (Light On or Color Match)
- DO (Dark On or No-Match)
- Mute (Channel Off)

REMOTE CAPTURE INPUT

- Input time: 25ms (ON) / 25ms (OFF) minimum
- Selectable (sinking or sourcing)
- Contact or solid-state input 1mA
- Transient suppression

GATE INPUT

- Selectable NPN/sinking or PNP/sourcing
- Selectable EDGE or GATE trigger for latch reset or inhibit for windowing
- Contact or solid-state input 1mA
- Transient suppression

TIMER

- On delay, off delay, one shot, and latch
- Duration: 1mS to 10 seconds +/-1%

DETECTION MODE

- Color or color + intensity

ALPHANUMERIC DISPLAY

- 4-Channel Color Monitor for at-a-glance performance feedback
- Alphanumeric display for available options

RESPONSE TIME

- Color-to-color: CW-1: 75µs (Uspd), 150µs (Hspd), and 300µs (Hres); CW-2: 600µs
- Shade-to-shade: CW-1/CW-1S: 100µs (Uspd), 200µs (Hspd), and 800µs (Hres); CW-2: 800µs

DIAGNOSTIC INDICATORS

- Output Indicator - (Amber) CH 1 through CH 4
- Four character alphanumeric display - (Green)

AMBIENT LIGHT IMMUNITY

- Responds to sensor's pulsed modulated light source - immune to most ambient light including indirect sunlight

HUMAN INTERFACE

- PUSH-BUTTON control: Select, Next

AMBIENT TEMPERATURE

- -5°C to 55°C (23°F to 131°F)
- No ice, frost, or fogging allowed

STORAGE TEMPERATURE

- 5°C to 90°C (41°F to 104°F)

RELATIVE HUMIDITY

- 35% to 85%

VIBRATION

- 10 to 55Hz, 0.5mm, 30 minutes each axis

SHOCK

- Half-sine wave, 30g, 1µs 6 times 3 axis

CERTIFICATIONS

- CE - Complies with IEC 60947-5-2 edition 3.0 2007-10
- UL & CUL listed; CCN NRKH & NRKH7

LENS MATERIAL

- Acrylic or glass

RUGGED CONSTRUCTION

- Chemical resistant, high impact polycarbonate housing
- Waterproof ratings: NEMA 4, IP65.

RoHS Compliant
Product subject to change without notice

Connections and Dimensions

SMARTEYE® ColorWise™

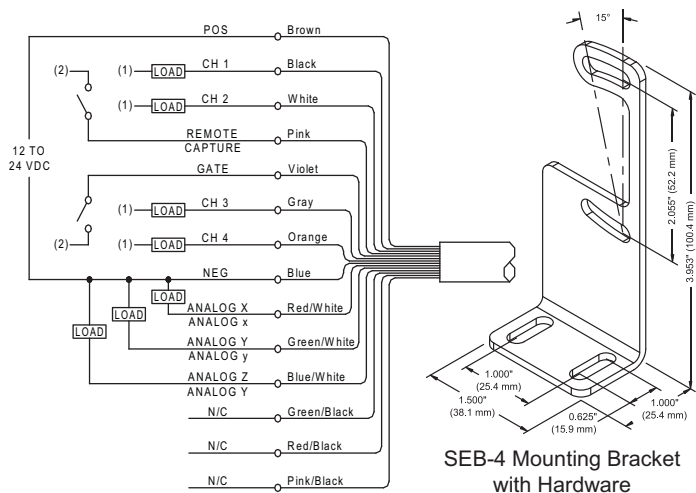
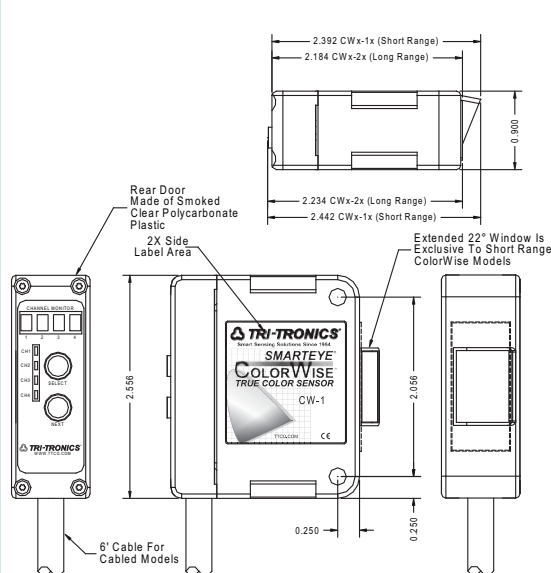

- (1) NPN (SINKING) OUTPUT LOAD TERMINATED TO POSITIVE
PNP (SOURCING) OUTPUT LOAD TERMINATED TO NEGATIVE
- (2) NPN (SINKING) INPUT ACTIVATED BY CONNECTING TO NEGATIVE
PNP (SOURCING) INPUT ACTIVATED BY CONNECTING TO POSITIVE

For connector models use:
BCC-6 - 6 ft. 14 Wire Cable with ¼ Turn Locking Connector

