



LOAD CELLS



C o n t e n t s

About Load Cells		1
Measuring System Block Diagram		6
Application Examples		8
Load Cell Selection Chart		10
Small-Sized Compression	LMA-A	16
Small-Sized Compression	LMB-A	17
Small-Sized Compression	LMBT-A	18
Small-Sized Compression	LMR-S-SA2	19
Small-Sized Compression	LCN-A	19
Small-Sized Compression	LCX-A-ID	22
Small-Sized Large-Capacity Compression	LCR-G-SA2	24
Small-Sized Compression	LC-V	25
Steady Brace	CR	27
Small-Sized Compression	LCV-A	28
General-Purpose Compression	LC-E	29
Highly Accurate Compression	LCH-F	30
Thin Compression	LCK-A	31
Corrosion-Resistant Compression	LC-J	33
Washer-Type	LCW-C-SA3	34
Washer-Type	LCW-D-S/E-S	35
Stainless Steel	LCTS-B	36
Thin Load Cells "Multiforce Sensor"	LCTA-A	37
Thin Load Cells "Multiforce Sensor"	LCTB-A	38
Thin Load Cells "Multiforce Sensor"	LCTE-A	39
Thin Load Cells "Multiforce Sensor"	LCTD-A	40
High/Low Temp. Compression	LC-FH	42
High/Low Temp. Tension	LT-FH/LT-FL	43
High-Accuracy Tension	LTZ-A	44
Tension/Compression	LU-E	45
Compact Tension/Compression	LUR-A-SA 1	48
Compact Tension/Compression	LUX-B-ID	49
Small-Capacity Tension/Compression	LU-A	52
High-Accuracy Tension/Compression	LUH-F	53
Beam-Type	LUB-B	55
Beam-Type	LUB-C	56
Ultrasmall-Capacity	LVS-A	57
Ultrasmall-Capacity	LTS-A	58
Tension/Compression	LUK-A	59
Compact 6-Component Force Transducers	LFM-A	61
Compact 6-Component Force Transducers w/Built-in Amplifier	LFX-A	62
6-Component Force Measuring System	LAT-1000A Series	63
3-Component Force Transducers	LSM-B-SA 1	65
Jack Load Cells	LUR-B-SA 1	66
Crane Load Cells	LTA-B-S/C-S	67
One-End Revolving Tension	LTR-S-SA 1	68
Pin-Type	LTP-S-S	69
Rectangular	LCD-A-S1 to S9	70
Rectangular	LCD-B-S	71
Rectangular	LCD-C-S	72
Rectangular	LCD-D-S	73
Tension Meter Load Cells	LCR-B-S7	74
Customized Load Cells		75
Special Accessories to Load Cells		78
Terminology		83

To Ensure Safe Usage

1. The rated capacity of the load cell is designed for cases of center spindle loads only. In cases involving inclined loads, rotary moment, horizontal force or bending moment, the load cell may be damaged. Please consult with KYOWA with applications of these types.
2. Load cell loads involving shocks or vibrations are measured as 'static load x acceleration.' When acceleration is unknown, be certain to prepare adequate rated capacity.
3. With tension/compression repetitive loads, use at less than 1/2 the rated capacity, in order to extend the fatigue life.
4. Special accessories are designed only for use with KYOWA load cells.
5. To cope with unforeseeable complications, take necessary precautions to ensure that no danger will ensue in the event of a broken load cell.
 - 1) Tension load cells
 - For tension type applications, only use special accessories assembled and incorporated into the load cell by KYOWA.
 - When loads are suspended, select a rated capacity that will ensure an adequate factor of safety, and add safety devices to prevent load dropping. (With static breaking loads, consult the table of dimensions for special accessories.)
 - Tension-type load cells are joined by screwing. Always make sure the screws are tightened completely. When using setscrews, make sure the screw fits perfectly into its counterpart, and check regularly for any loosening of the screws.
 - 2) Compression load cells
 - In the event of buckling of the strain column of load cell, height is reduced by a few to 10s mm and the load will be supported by the outer case. Consider the effect of such dimensional changes on the load cell attachment area, device, etc.
6. Check periodically to make sure the load cell fixing screws have not become loose. If looseness is detected, tighten completely.
7. Consult with KYOWA concerning usages involving factors of safety, etc. stipulated by law (cranes, etc.).

Read This Before Reading This Catalog

- Natural frequencies quoted in the text are only approximate.
- Specifications, design, etc. are subject to change without notice.
- Consult with KYOWA before using the products described for special applications.
- Measurements given in the text are in millimeters (mm).
- Weight referred to in the text applies only to the unit and does not include cables.

There are so many reasons why KYOWA strain-gage load cells are ideal as sensors for weighing systems

KYOWA load cells offer outstanding and sustained performance over long periods of usage, even under harsh operating conditions, thanks to their adoption of our independently developed, dedicated strain gages of excellent accuracy, our superior production technologies and calibration equipment of supreme precision, and our rich experience in this field. We offer a full range of models to satisfy all industrial needs, including: models for compression and tension applications; washer type models for measuring rolling pressure, etc.

KYOWA load cells can be used in sensing applications ranging from general force measurement in testing or research to measuring and controlling weight (mass) in tanks, hoppers, mills, vehicles, etc. All KYOWA load cells are built to provide high precision, stability and air-tight reliability as demanded for a broad array of industrial requirements. Discount is available to clients placing high-volume orders. Inquiries are welcome.

Load Cell (Load Transducer)

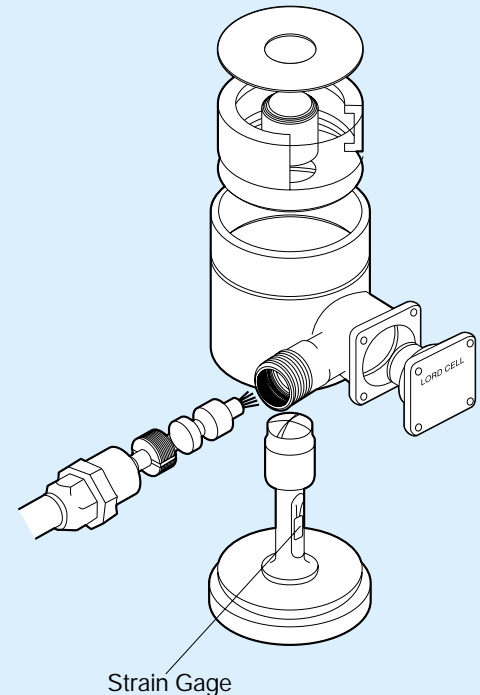

1

Outstanding weighing accuracy

Strain-gage load cells perform measurement tasks by converting weight, force, etc. to electrical output by use of a strain gage. KYOWA load cells feature strain gages of outstanding precision developed specifically for use in the company's load cells, built to offer maximum resistance against the effects of aging, ambient temperature, etc. They were developed applying nearly half a century of experience in this field, and are manufactured by KYOWA's superior production technologies and outstandingly precise calibration equipment. KYOWA strain-gage load cells are notable for their compact size, light weight, extremely modest mechanical displacement, simple structure, easy installation and maintenance over long periods of usage.

2

Long-term stability even under harsh operating conditions

Nearly all KYOWA load cells feature an air-tight structure containing inert gas. A configuration of this kind enables the prevention of the major causes of aging, including reduced insulation resistance and changes in the compensation resistance of the strain gage, etc. As a result, KYOWA load cells are able to maintain their initial high accuracy over a protracted time frame, even when used under harsh operation conditions.

One important consideration when load cells are used repeatedly is the approximate number of times such usage is possible. KYOWA load cells offer outstanding service life: more than 10 million operations with the LCN-A and LCV models (under 100% load).

3

Remote instruction and control

Because load cells convert load and force to electrical signals, they can be instructed from, or their data can be recorded at, remote locations. Traditionally, load cells have often been used in conjunction with testing or research, but more recently, in tandem with developments in peripheral technologies and trends toward labor saving and automation, they have come to be frequently used in production line weighing systems.

Configurations of Strain Column

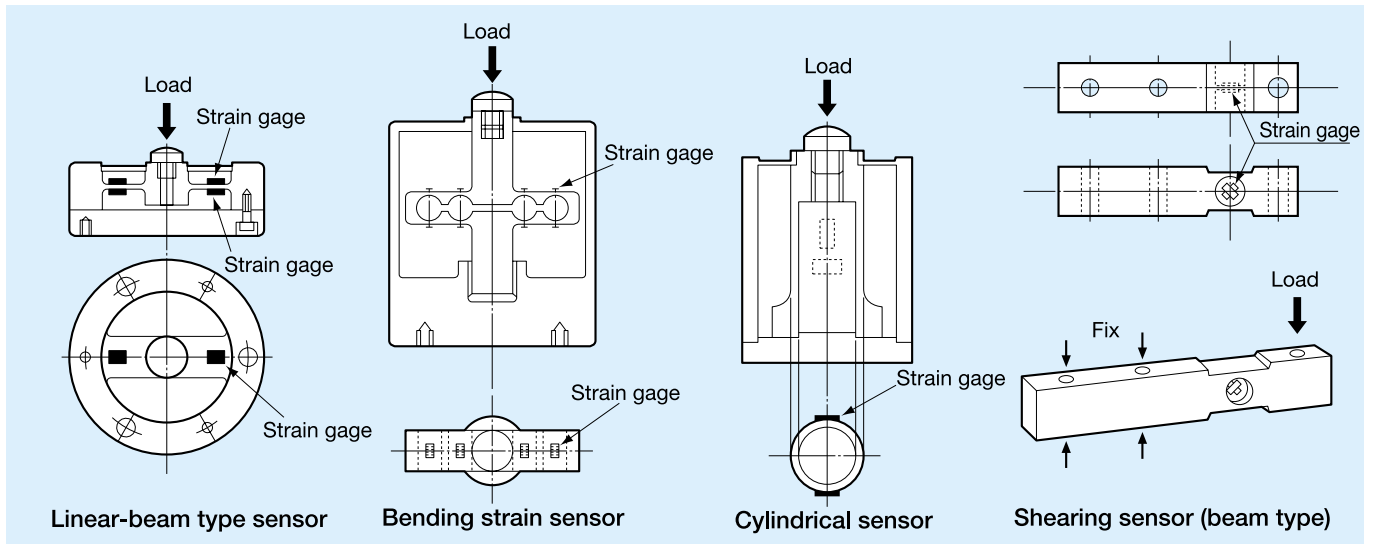

How to Install Load Cell and Special Accessories (For Accurate Measurement)

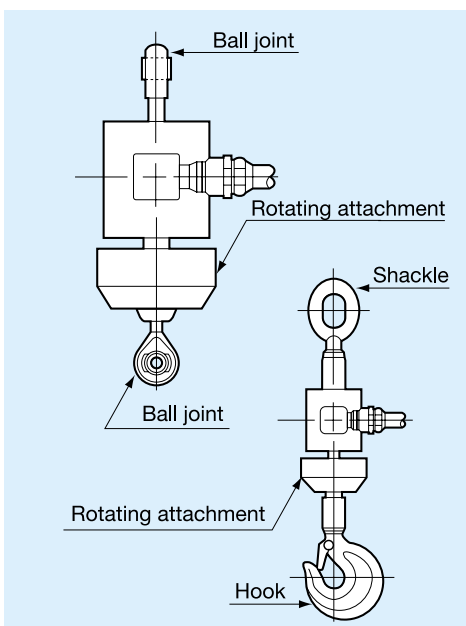
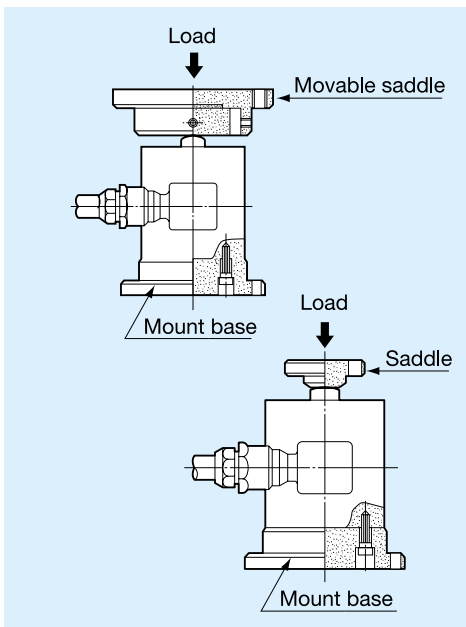

Compression Load Cells

- To install the saddle, prepare a steel plate and attach the accessory hexagon socket head cap screw to it. Weld the steel plate on the load point of measuring object or fix it on the load point with screws. To protect the saddle from rusting, grease it.
- Install the saddle and mount base so that each of their surface is horizontal to the load cell and a load is applied vertically to the load cell.
- Each load cell is designed to detect only the force applied to its central axis. Since the installation quality directly affects the measuring accuracy, install it carefully so that an inclining load, angular moment, horizontal force component and bending moment may not affect the load cell.
- Each load cell has a capability to sufficiently follow daily changes of temperature. However, if it is partially heated, the accuracy may be adversely affected transiently. If it cannot be avoided to use under temperatures beyond the specified operating temperature range, protect the load cell with a heat insulating material to keep it in the operating temperature range.
- If there is impact or vibration in the loading direction, it is difficult to determine the proper rated capacity of load cell unless the magnitude of acceleration is known. In such a case, therefore, select the load cell of which the rated capacity is sufficient enough. If the magnitude of acceleration is known, obtain the rated capacity by the product of weight and acceleration. If a weight including the tare weight is measured, obtain the rated capacity by adding the tare weight.

Tension Load Cells

- The tension load cell has one screw at the center of the upper and lower surfaces. Using the screws, set it in place taking care that any bending or angular moment may not be applied to the load cell during measurement. Such moment not only affects the measurement accuracy but also shortens the service life to a great extent.
- For the safe operation, select the load cell which provides a rated capacity sufficient enough to cover expected loads. Also, prepare safety devices against accidental hazards such as dropping.
- If the load cell with special accessories (such as TR, TH and RJ) attached is used at its full rated capacity or if there is a fear of overload, a problem on the mechanical strength may arise depending on the installation method. For solutions of such a problem, please contact us.
- When attaching the rotating attachment in the RJ-B series to the load cell, remove the coupling screw of the load cell. Then screw the rotating attachment with a proper tightening torque shown on the table above.
- When screwing a ball joint into the load cell, take care not to apply an excess torque to the load cell. Especially, a small-capacity load cell may be damaged by an excess torque.

Rated Capacity	0.5 to 2 kN (50 to 200 kgf)	5 to 20 kN (500 kgf to 2 tf)	50 kN (5 tf)	100 kN (10 tf)	200 kN (20 tf)
Tightening bolt	M6	M8	M10	M16	M20
Tightening torque (Approx.)	10 N·m (1 kgf·m)	30 N·m (3 kgf·m)	70 N·m (7 kgf·m)	270 N·m (27 kgf·m)	560 N·m (56 kgf·m)

■ TEDS

To obtain a correct value by using a transducer and a measuring instrument, the measuring instrument should be adjusted based on calibration data of the transducer. Conventionally, such adjustment has been done manually. TEDS-installed transducers have their own information saved in memory to let TEDS-compatible instrument read the data for automatic adjustment, thereby contributing to time and labor savings and prevention of erroneous setting.

■ Relation between Strain and Voltage in Transducer Outputs

The output of a strain gage transducer is expressed in either strain ($\mu\text{m}/\text{m}$) or voltage (mV/V or $\mu\text{V}/\text{V}$; voltage per 1 V bridge voltage). The strain quantity, ε , and output voltage, e , have the following relation:

$$e = \frac{1}{4} K_s \cdot E \cdot \varepsilon$$

where, K_s : Gage factor of transducer
 E : Excitation voltage

$$\therefore \frac{e}{E} = \frac{1}{4} K_s \cdot \varepsilon$$

Suppose the gage factor, K_s , is 2.00. Then,

$$2 \frac{e}{E} = \varepsilon, \text{ and if } E = 1 \text{ (V)}, 2e = \varepsilon$$

Thus, the strain output and voltage output always have a relation of 2:1.

e.g. $3000 \mu\text{m}/\text{m} \Rightarrow 1500 \mu\text{V}/\text{V}$ or $1.5 \text{ mV}/\text{V}$

■ Conversion of Strain Quantity (Voltage) Measured by Transducer into Proper Physical Quantity

Strain quantity (or voltage) measured by a transducer such as load cell or pressure transducer is converted into the physical quantity in proper engineering unit as follows.

- The following 2 types of calibration coefficients are stated in KYOWA's Test Data Sheet. Use a proper one for the applied measuring instrument.

A: Calibration factor indicating the physical quantity corresponding to a reference equivalent strain of $1 \mu\text{m}/\text{m}$

B: Calibration factor indicating the physical quantity corresponding to an output voltage of $1 \mu\text{V}$ against a bridge excitation voltage of 1 V.

- When using a strain amplifier
 Wanted physical quantity = Measured strain ($\mu\text{m}/\text{m}$) x A
- When using an amplifier other than strain amplifier or recorder

$$\text{Wanted physical quantity} = \frac{\text{Bridge output voltage } (\mu\text{V})}{\text{Bridge excitation voltage (V)}} \times B$$

■ Connection for Getting Average Output Value of Transducers of Same Model

If multiple transducers of the same model are connected in parallel, an average output voltage "e" can be obtained through the following equation, provided that the output resistance of each transducer is equal.

$$\text{Average output voltage } e = \frac{e_1 + e_2 + \dots + e_n}{n}$$

where, e_1, e_2, \dots, e_n : Output voltage of each transducer

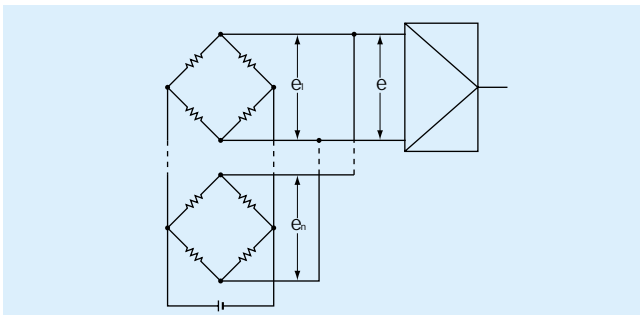

■ Advantages of Remote-Sensing Method

In measurement with the highly-accurate transducer connected through a long extension cable, cable conductor resistance and ambient temperature change cause measurement errors. The remote-sensing function removes these factors causing errors and stabilizes the bridge voltage.

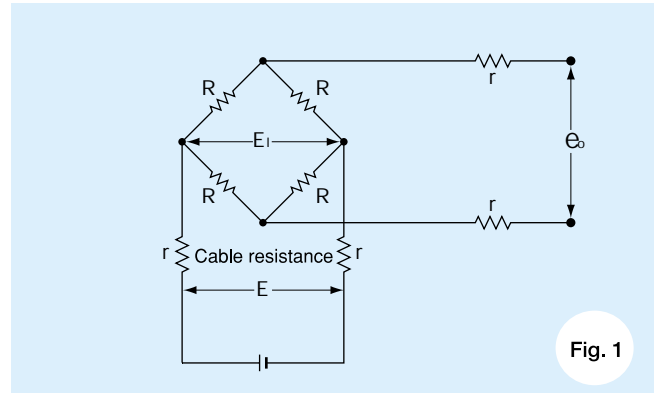

Fig. 1

If, for example, the 0.5 mm^2 -conductor cable is extended by 100 m, the conductor resistance is approximately 4.0Ω . If the cable resistance "r" in Fig. 1 is 4.0Ω , the reciprocating resistance on the input circuit is 8.0Ω . Suppose input and output resistances are 350Ω , then the voltage at both ends of the bridge is:

$$\frac{350E}{350 + 8.0} = 0.978E \text{ (V)}$$

where, E : Supply voltage (V)

Since there exists a relation of $e_0 = \frac{E_1}{4} K_s \cdot \varepsilon$,

the sensitivity of the transducer lowers by approximately 2.2%.

Furthermore, if the ambient temperature changes by 10°C during measurement, the voltage at both ends of the bridge fluctuates by approximately 0.1%, and the merit of the transducer featuring an accuracy of 0.02% RO is lost. With the remote-sensing method, a pair of cables for error detection are added to the input side of the bridge, thereby making the number of conductors 6.

The bridge voltage is lowered by the cable resistance "r" and the lowered voltage is sent to the error amplifier through error detection conductors. Then, it is compared with the reference voltage and a difference of the voltage is amplified by the high-amplification and high-impedance error voltage amplifier. Since the output of this amplifier drives the control circuit, the input voltage of the bridge is kept constant irrespective of the cable resistance "r," thereby enabling accurate and stable measurement. With this remote-sensing method, connections and conductor colors are as shown in Fig. 2.

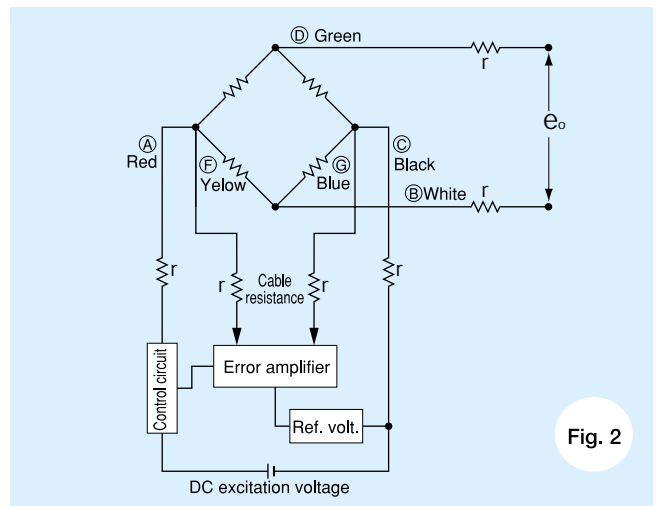
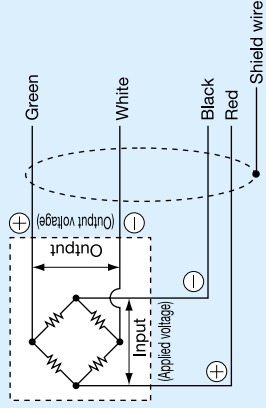

Fig. 2

Load Cell's Bridge Circuit and Cable Connection

In the case of cable bared at the tip



In the case of cable terminated with NDIS connector plug

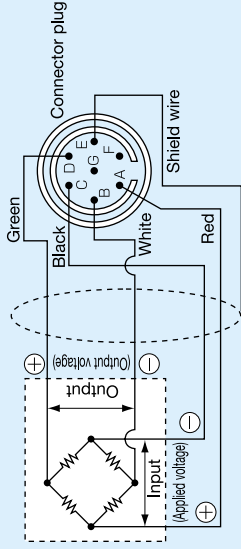

With most KYOWA load cells, the shield wire is not connected to the mainframe.

Resistances between conductors and between terminal pins

Terminal pins	Input (A-C)	Output (B-D)	A-B	A-D	B-C	C-D
Conductors	Red-Blk	Whit-Grn	Red-Whit	Red-Grn	Whit-Blk	Blk-Grn
Bridge resistance	350 Ω	350 Ω	262.5 Ω	262.5 Ω	262.5 Ω	262.5 Ω
(R)	120 Ω	120 Ω	90 Ω	90 Ω	90 Ω	90 Ω

Sensitivity Decline due to Cable Extension

If the cable between the load cell and amplifier/conditioner is extended, the extension cable resistance lowers the applied voltage to the load cell. This results in sensitivity decline which cannot be ignored.

The rated output affected by the sensitivity decline can be obtained through the following equation.

$$\epsilon_0 = \left(\frac{R}{R + (r \times L)} \right) \epsilon_i$$

where, R: Input resistance of load cell (Ω)

r: Reciprocating resistance of extension cable by 1 m (Ω)

L: Length of extension cable (m)

ε_i: Rated output stated in the Test Data Sheet.

KYOWA extension cables (N-82 to 85 and 100) and sensitivity decline

Model	Cable Length (L)	Sensitivity Lowering Ratio (Approx.)	Reference	
			r x L (Ω) (Approx.)	R / (R + (r x L))
N-82	10 m	0.2%	0.8	0.998
N-83	20 m	0.5%	1.6	0.995
N-84	30 m	0.7%	2.4	0.993
N-85	50 m	1.1%	4	0.989
N-100	100 m	2.2%	8	0.978

Bridge resistance R = 350 Ω

Extension cable: 4-conductor (0.5 mm²) chloroprene shielded cable

Reciprocating resistance of cable per 1 m: 0.0794 Ω ≈ 0.08 Ω

How to Obtain Proper Rated Capacity of Load Cell

● If the weighing object is a low-viscosity liquid showing less horizontal movement with both the container and content and initiating less impact, obtain the proper rated capacity of load cell through the following equation:

$$L \geq \frac{H+F}{n} \times 1.1$$

where, L: Capacity of load cell n: Number of load cells

H: Weighing capacity F: Tare

If there is vibration, use a higher factor in a range of 1.1 to 1.5 according to the degree of acceleration.

● If the weighing object is powder or high-viscosity liquid, change the factor to 1.3 in the equation above. Also, if there is vibration, use a higher factor in a range of 1.3 to 1.5.

● If the weighing object including the container shows less horizontal movement but initiates big impact, obtain the rated capacity through the following equation:

$$L \geq \frac{S+F}{n} \times 1.3 \quad \text{where, S: Maximum impact load}$$

● If the weighing object including the container shows horizontal movement and initiates big impact, obtain the rated capacity through the following equation:

$$L \geq \frac{2S+F}{n} \times 1.3$$

If the impact is repeatedly initiated, change the factor to 1.7.

The abovementioned equations are on the supposition that the load is evenly allotted to all load cells used in a multiple number. If the load is unevenly allotted, determine the rated capacity considering the load given to the load cell to which the biggest burden is allotted.

In the case of a hanging type system, it is recommended to select a rated capacity 2 times higher than obtained through each of the abovementioned equations, to ensure safe operation.

How to Obtain System Accuracy of Load-cell Based Weighing System

To obtain the accuracy of an electronic load-cell weighing system, load-cell installation quality and errors due to vibration, etc. should be considered together with intrinsic errors of load cell and amplifier and ambient temperature change. Here, we simplistically explain the method of calculating the system accuracy by taking the case where static errors of load cell and amplifier are main factors affecting the system accuracy.

Obtain the accuracy of the detecting section including the load cell and the accuracy of the amplifier. Then, obtain the system accuracy by calculating the square root of the sum of their squares.

$$\text{System accuracy } E = \sqrt{E_r^2 + E_l^2}$$

where, E_r: Accuracy of detecting section

E_l: Accuracy of amplifier

Generally, the accuracy of detecting section is obtained through the following equation:

$$E_r = \sqrt{E_1^2 + E_2^2 + E_3^2 + (E_4 \times \Delta t)^2 + (E_5 \times \Delta t)^2}$$

where, E₁: Nonlinearity

E₂: Hysteresis

E₃: Repeatability

E₄: Temperature effect on zero (°C)

E₅: Temperature effect on output (°C)

Δt: Change of ambient temperature

If multiple load cells are used,

$$E_r(n) = \frac{E_r}{\sqrt{n}} \quad \text{where, n: Number of load cells used}$$

Generally, the accuracy of amplifier is obtained through the following equation:

$$E_l = \sqrt{E_{11}^2 + (E_{12}^2 + \Delta t)^2 + (E_{13} \times \Delta H)^2 + E_{14}^2 + E_{15}^2}$$

where, E₁₁: Nonlinearity

E₁₂: Temperature effect on zero (°C)

E₁₃: Temperature effect on sensitivity (°C)

E₁₄: Aging effect on zero

E₁₅: Aging effect on sensitivity

Installation of Load Cell to Hopper or Tank

Usually, it is desirable that a total weight including the tare weight of hopper or tank is evenly loaded onto each load cell. If the loading point moves and the centroid is not fixed, estimate the locus of the centroid and referring to the typical position, arrange each load cell so that a maximum load is evenly imposed on each load cell. Also, select load cells of which the rated capacity is sufficient enough to cover the expected maximum load.

There may be two installation methods: standard and simplified. With the standard method, a load is wholly received by load cells alone. With the simplified method, a load is received by load cells, load cell dummies, pivots and hinges in combination. For the types of hoppers and tanks and the number of devices required for each installation method, see the table below.

Type		Horizontal	Vertical Cylindrical	Square	Special	1-point Hanging	2-point Hanging	3-point Hanging
Shape								
Standard Method (Liquid, Powder)	Load Cells	4	3	4	4	1	2	3
	Check Rods	6 to 8	6	4 to 8	8	4 to 6	4 to 8	6
Simplified Method (Liquid Only)	Load Cells	2	1	2	As a rule, the simplified method is not applicable for the special type hoppers or tanks.	—	—	—
	Dummy Load Cells	2	2	2				
	Check Rods	4	4	4				

Characteristics of Standard Method

- Load cells receive the whole load, thereby enabling measurement with minimal effect of fluctuation of the centroid.
- No restriction for application: solid, powder or liquid.
- Measurement accuracy receives minimal effect of external factors such as temperature, vibration and installation conditions.
- Accuracy of load cells is fully utilized.

Characteristics of Simplified Method

- Use of dummies and hinges enable economical construction.
- Weighing materials are limited to liquid.
- Hard to use for special types of hoppers and tanks and not applicable for those of which the centroid moves.
- Hinges should be installed carefully.
- Subject to adverse effects of vibration and temperature.

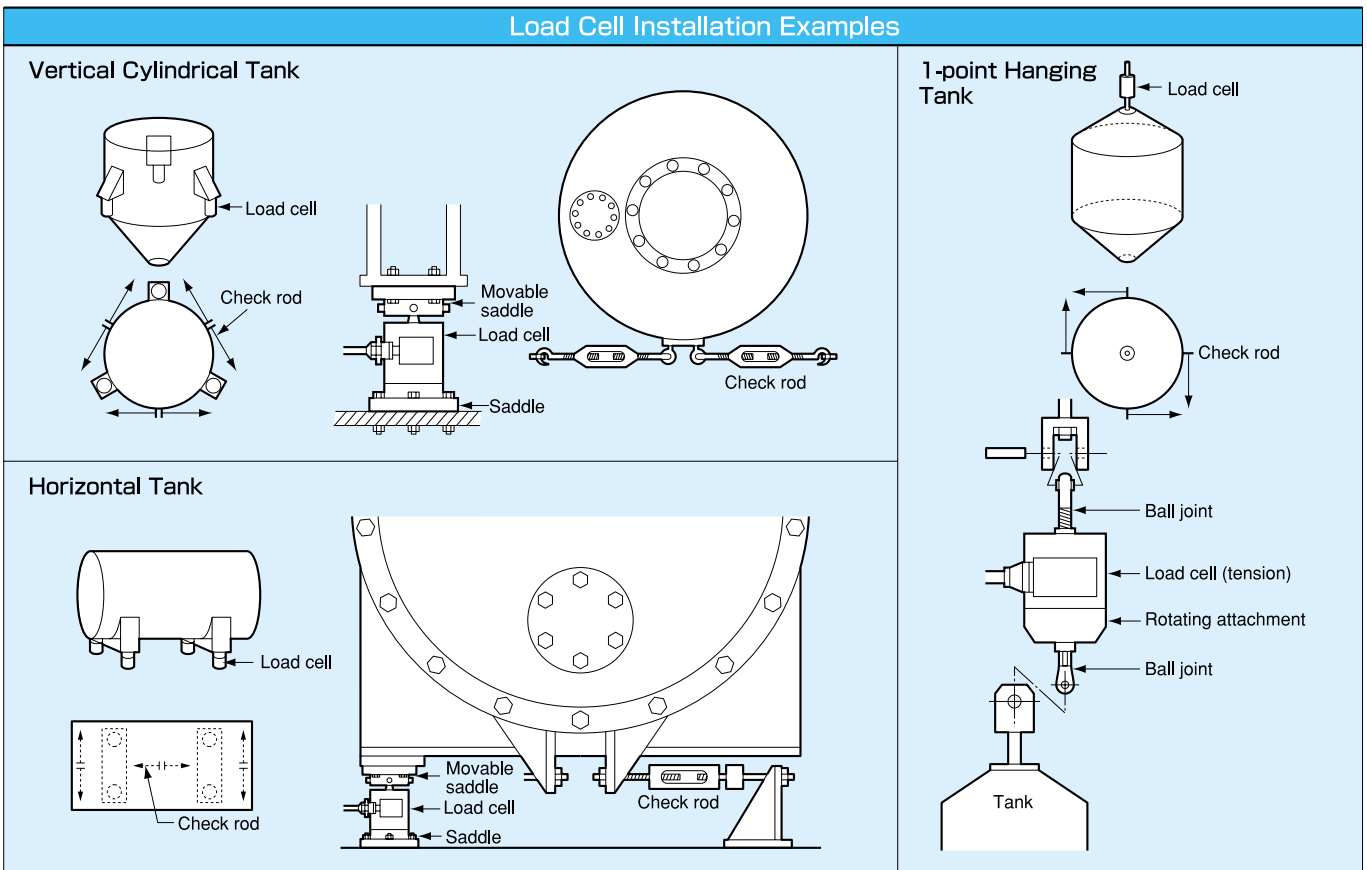

Measuring System Block Diagrams

● Indication, Measurement, Control & Monitor

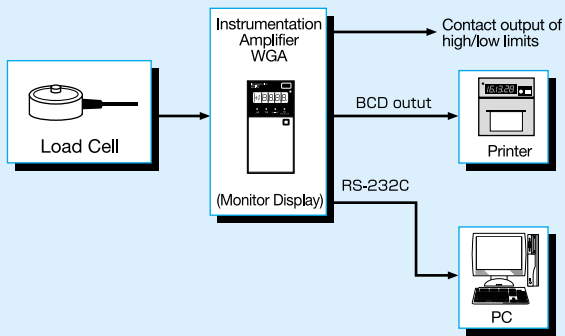

● Measurement of Dynamic Variables

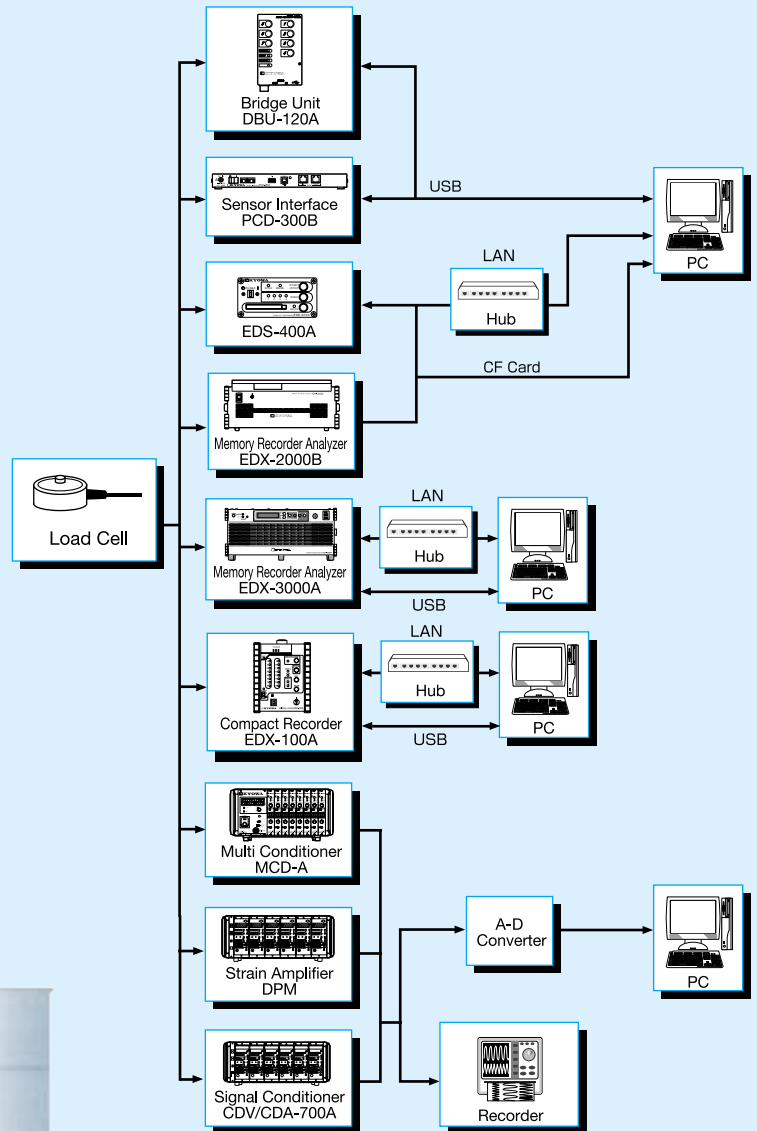

● Measurement of Static Variables with Data Loggers

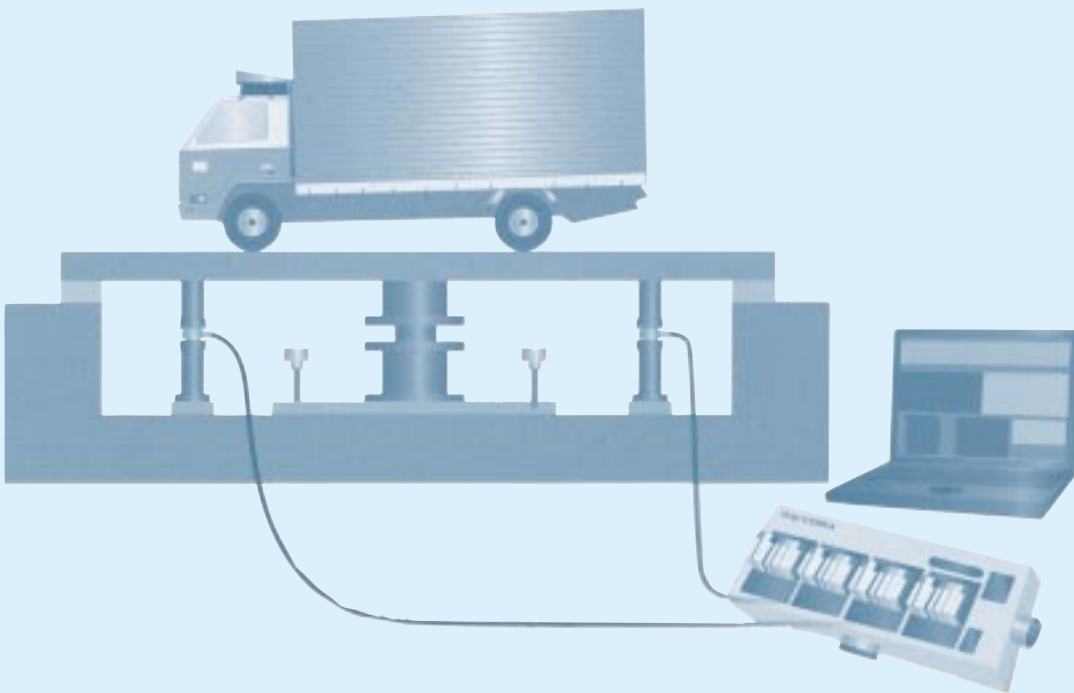
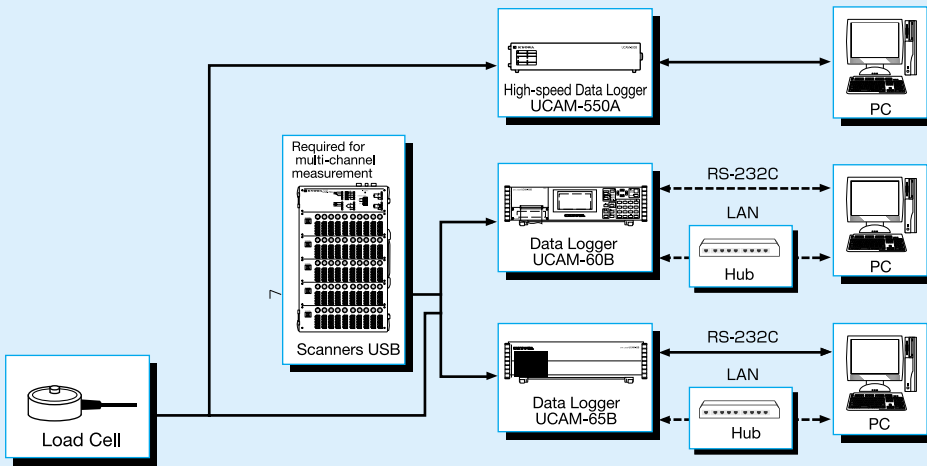

Individual catalog is available for each of the products described above. Inquiries are welcome.

With their full capabilities from sensors to data load cell possibilities expand to systemization,

Coefficient of friction measurement

Applicable products

LVS LTS LUR-A

Load cells can be used to measure the coefficient of friction of an object. For example, by loading the test material onto a truck and pulling the truck, the coefficient of static friction is measured.

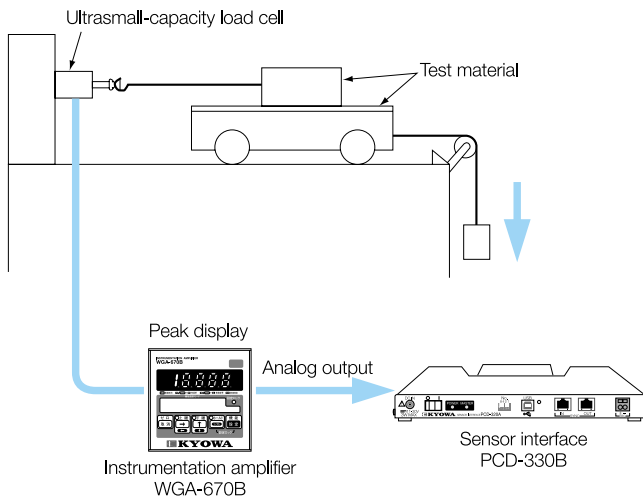

Truck scale

Applicable products

LCX-A LCN-A LC-V LCV-A

When a truck is positioned onto a scale, the output from each load cell (normally, 4 units) is received at a junction box and total output is calculated. Tare compensation is performed, and the weight of the frame is subtracted, enabling measurement of the weight of the truck itself. When used in conjunction with upper/lower limit-setting devices, warnings can be issued to inform of overloads, thereby enabling safety management.

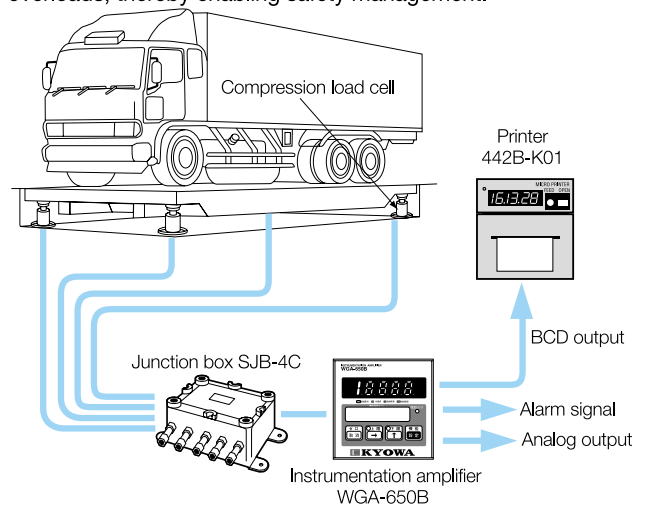

Measurement of animal weight

Applicable products

LUB LCX-A LC-V

This is a device that enables measurement of an animal's weight without frightening the animal. Four beam-type load cells are used to detect the load positioned on the detection bed, and the weight is displayed on the WGA-650B. Weight can also be recorded using the accessory printer. By embedding the device in the ground, it is possible to guide the animal to walk over the level surface for weighing.

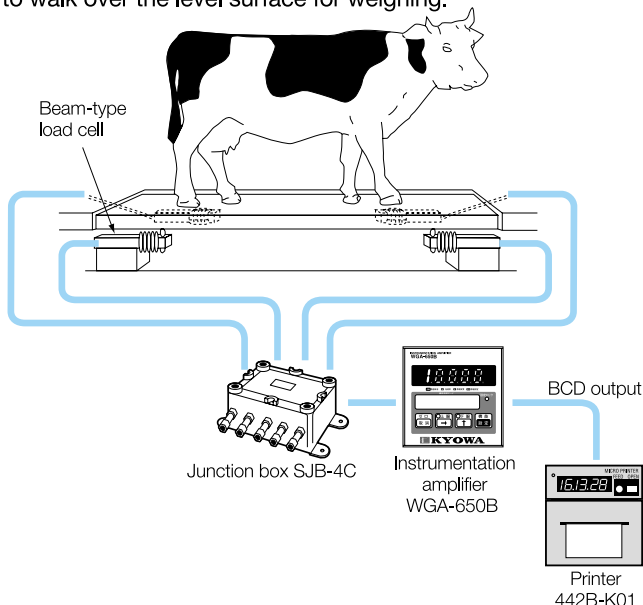

Load monitor for overhead traveling crane

Applicable products

LCD-A LCX-A LC-V

This load monitor is used to measure a load suspended from an overhead traveling crane. The load applied to the wire-rope winder drum axle is measured by load cell (1 or 2 units), and the result is displayed. With use of a conditioner equipped with control contact points, it is possible to perform winch control (for example, to prevent hoisting of overloads, to enable safety control).

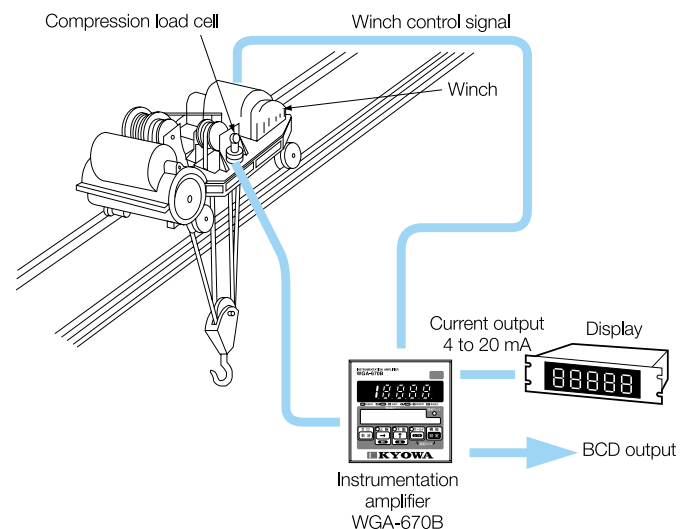

processing, manpower saving and automation.

Load control for load testing of structures

Applicable products **LUR-B** **LUK-A** **LCX-A** **LMR** **LC-V**

Load cells can be used in conjunction with an oil jack to measure the strength of structures of all kinds: automobiles, aircraft and ships. By combining the load cells with an instrumentation conditioner, the pressure load can be detected and displayed digitally. When an external digital display device is provided, operation can be performed while monitoring in real time. In addition, when a large-capacity displacement transducer (DTP-D-S) is used to detect the kinetic displacement of the load bed, it is possible to measure the correlation between the load beds weight and displacement.

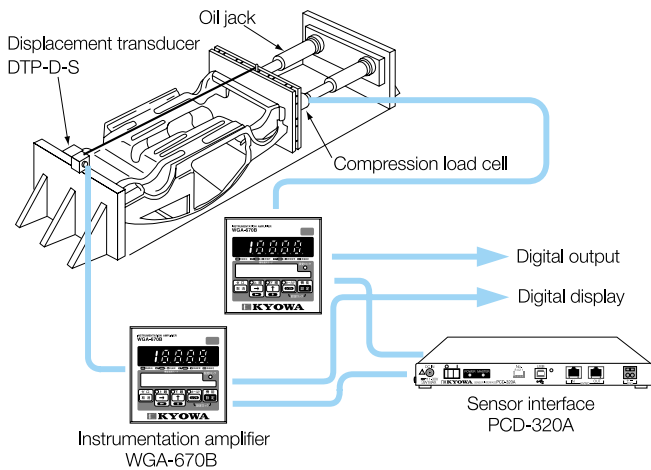

Tank scale

Applicable products **LCX-A** **LC-V** **LCV-A** **LUB**

By measuring the weight of multiple tanks as well as the weight of what each tank can contain, it is possible to achieve automation and labor saving in mixing operations. Generally, each tank is outfitted with 3 to 4 load cells, and their respective outputs are combined at a junction box. Conditioning is then performed by the WGA series and the results are displayed. This configuration makes it possible to use signals to control the volume of what goes into the tanks.

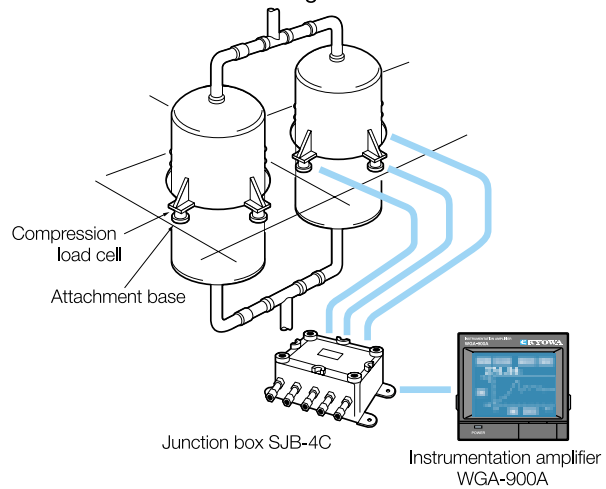

Press-fit load measurement device

Applicable products **LMB-A** **LMR** **LUR-A**

Manufacturers of automotive components use load cells and peak hold displays to control press-fitting load during the press-fitting process when making car air-conditioner parts. KYOWA's press-fit load measurement device can be utilized not only by automotive component makers but also by producers of a broad range of parts and machining tools.

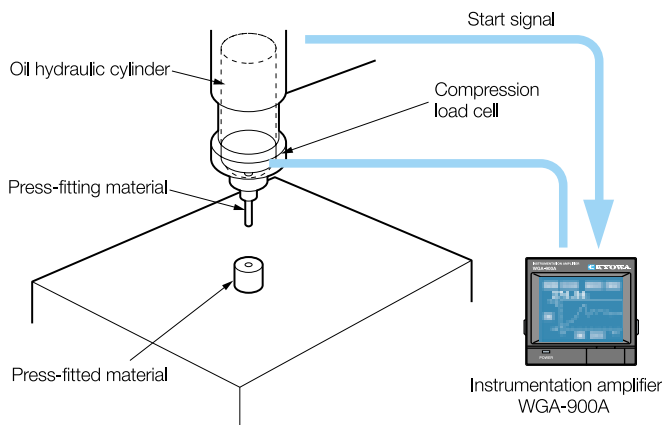

Tension control of film, sheets, etc.

Applicable products **LCR-B** **LMB-A** **LMR** **LCX-A**

This device is used to maintain uniform tension in order to assure quality control when film, sheets and other materials are wound on reels during the production process. Load cells are installed on the bearings at both ends of the roller, and tension is measured by combining the output of both load cells. It is also possible to monitor unbalanced load by measuring load cells individually.

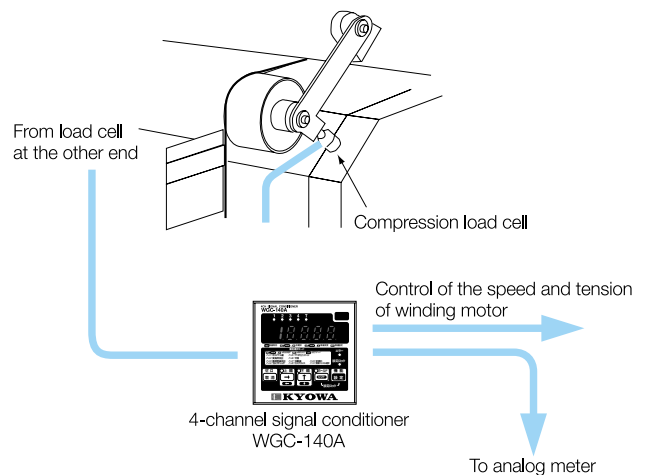

Load Cells (Load Transducers) For Compression Load Measurement

Small-Sized Load Cells

Small-sized for load distribution measurement

LMA-A

Miniature Compression Load Cells
5 N to 1 kN



See page 16

Ultra-small

LMB-A

Miniature Compression Load Cells
10 N to 2 kN



See page 17

Ultra-small

LMBT-A

NEW

Small-Sized Compression Load Cells
50 N to 2 kN



See page 18

21 mm diameter

LMR-S-SA2

Miniature Compression Load Cells
2 to 20 kN



See page 19

Small-sized and lightweight

LCX-A-ID

Miniature Compression Load Cells
500 N to 20 kN



See page 22

Beam-Type Load Cells

Small-sized and lightweight

LUB-B

Beam-Type Compression Load Cells
50 N to 20 kN



See page 55

Nonlinearity 1/2000

LUB-C

Beam-Type Compression Load Cells
500 N to 20 kN



See page 56

High-Accuracy Load Cells

Nonlinearity 1/5000

LCH-F

Highly Accurate Compression Load Cells
100, 200 kN



See page 30

Nonlinearity 1/2000

LC-V

Miniature Compression Load Cells
50 to 200 kN



See page 25

Large capacity, nonlinearity 1/1000

LCV-A

Miniature Compression Load Cells
500 kN, 1 MN



See page 28

Stainless steel make

LCN-A

Miniature Compression Load Cells
500 N to 20 kN



See page 20

20 or 25 mm diameter

LCR-G-SA2

Small-Sized, Large-Capacity
Compression Load Cells

5 to 50 kN



See page 24

Large capacity

LC-E Made to order

General-Purpose Compression Load Cells

2, 5 MN



See page 29

As thin as 25 to 50 mm in total height

LCK-A

Thin Compression Load Cells
5 to 200 kN



See page 31

Stainless steel make

LC-J Made to order

Corrosion-Resistant Compression Load Cells

5 to 200 kN



See page 33

For high temperatures

LC-FH

Compression Load Cells

500 N to 200 kN

LC-FH: -10 to 150°C



See page 42

Model	Rated Capacity																									Ref. Page						
	N										kN										MN											
	5	10	20	50	100	200	300	500	1	2	5	10	20	30	50	100	200	500	1	2	5											
LMA-A	█										█																			16		
LMB-A	█		█										█																			17
LMBT-A	█		█										█																			18
LUB-B	█										█																				55	
LCX-A-ID	█										█																				22	
LCN-A	█										█																				20	
LC-FH	█										█																				42	
LUB-C	█										█																				56	
LCR-G-SA2	█										█																				25	
LCK-A	█										█																				31	
LMR-S-SA2	█										█																				19	
LC-J	█										█																				33	
LC-V	█										█																				25	
LCH-F	█										█																				30	
LCV-A	█										█																				28	
LC-E	█										█																				29	

Load Cells (Load Transducers) For Tension Load Measurement

For high/low temperatures

LT-FH/FL

Tension Load Cells

500 N to 200 kN

LT-FH: -10 to 150°C

LT-FL: -196 to 30°C



See page 43

For measurement of load applied perpendicularly to rod

LVS-A

Ultra-small Capacity Load Cells

50 mN to 20 N



See page 57

For measurement of load applied horizontally to rod

LTS-A

Ultra-small Capacity Load Cells

500 mN to 20 N



See page 58

Nonlinearity 1/3333

LTZ-A

Highly-Accurate Tension Load Cells

500 N to 50 kN



See page 44

Model	Rated Capacity																Ref. Page			
	mN				N								kN							
	50	100	200	500	1	2	5	10	20	50	100	200	500	1	2	5		10	20	50
LVS-A	█																57			
LTS-A					█												58			
LTZ-A													█				44			
LT-FH/FL													█				43			

Load Cells (Load Transducers) Component Force Transducers

For 3-component force measurement

LSM-B-SA1

3-Component Force Transducers

10 to 500 N



See page 65

For 6-component force measurement

LAT-A

6-Component Force Transducers

100 to 300 N



See page 63

For 6-component force measurement

LFM-A

Compact 6-Component Force Transducers

1, 3 kN



See page 61

For 6-component force measurement

LFX-A

Compact 6-Component Force Transducers

with Built-in Amplifier

1, 3 kN



See page 62

Model	Rated Capacity									Ref. Page	
	N						kN				
	10	20	50	100	200	300	500	1	3		
LSM-B-SA1	█						█				65
LAT-1000A	█									63	
LFM-A							█			61	
LFX-A							█			62	

Load Cells (Load Transducers) For Tension/Compression Load Measurement

• With tension/compression load cells, tension load causes plus output and compression load, minus output.

Small capacity

LU-A

Small-Capacity Tension/Compression Load Cells

±50 to ±200 N



See page 52

Inert gas sealed

LU-E Made to order

Tension/Compression Load Cells

±500 N to ±200 kN



See page 47

Thin, large capacity

LUK-A

Tension/Compression Load Cells

±5 kN to ±2 MN



See page 59

Diameter 28 mm, weight 80 g

LUR-A-SA1

Tension/Compression Load Cells

±50 N to ±2 kN



See page 48

Compact

LUX-B-ID

Compact Tension/Compression Load Cells

±50 N to ±20 kN



See page 49

Nonlinearity 1/5000

LUH-F

Highly-Accurate Tension/Compression Load Cells

±500 N to ±200 kN



See page 53

Model	Rated Capacity																Ref. Page
	N				kN								MN				
	50	100	200	500	1	2	5	10	20	50	100	200	500	1	2		
LU-A	■	■	■	■													52
LUR-A-SA1	■	■	■	■	■	■	■	■	■	■	■	■	■				48
LUX-B-ID	■	■	■	■	■	■	■	■	■	■	■	■	■	■	■	■	49
LU-E					■	■	■	■	■	■	■	■	■	■	■	■	47
LUH-F					■	■	■	■	■	■	■	■	■	■	■	■	53
LUK-A										■	■	■	■	■	■	■	59

Load Cells (Load Transducers) For Special Purposes

Load Cells for Steelmaking Line

Washer type for rolling mill

LCW-D-S

Washer-Type Load Cells

1 to 5 MN



See page 35

Washer type for rolling mill

LCW-E-S

Washer-Type Load Cells

1 to 5 MN



See page 35

LCD-B-S

Rectangular Load Cells

5 to 20 kN



See page 71

LCD-C-S

Rectangular Load Cells

50 to 100 kN



See page 72

LCD-D-S

Rectangular Load Cells

500 kN to 5 MN



See page 73

For tension meter

LCR-B-S7

Tension Meter Load Cells

5 to 200 kN



See page 74

Load Cells for Cranes

1 to 5 V output available

LTA-B-S/C-S

Crane Load Cells

20 to 500 kN



See page 67

For pulley axis of crane

LTP-S-S

Pin-Type Load Cells

10 to 500 kN



See page 69

Model	Rated Capacity															Ref. Page		
	kN										MN							
	5	10	20	30	50	70	100	200	250	300	500	1	1.5	2	3		3.5	5
LCD-B-S																		71
LCR-B-S7																		74
LCW-C-SA3																		34
LTP-S-S																		69
LUR-B-SA1																		66
LTR-S-SA1																		68
LTA-B-S																		67
LTA-C-S																		67
LCD-A-S																		70
LCD-C-S																		72
LCD-D-S																		73
LCW-D-S																		35
LCW-E-S																		35

Different diameters available

LCW-C-SA3

Washer-Type Load Cells

10 to 300 kN



See page 34

For pillow block load

LCD-A-S1 to S9

Rectangular Load Cells

30 to 100 kN



See page 70

For jack

LUR-B-SA1

Jack Load Cells

10 kN to 5 MN



See page 66

For rope tension measurement

LTR-S-SA1

One-End Revolving Tension Load Cells

20 to 50 kN



See page 68

Stainless Steel Load Cells

For food tank and hopper

LCTS-B

Stainless Steel Load Cells

5 to 100 kN

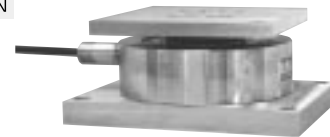

See page 36

Model	Rated Capacity											Ref. Page			
	N		kN												
	500	800	1	2	3	5	10	20	30	50	100		200	300	
LCTS-B															36
LCTA-A															37
LCTB-A															38
LCTE-A															39
LCTD-A															40

Thin Load Cells

For tank and hopper

LCTA-A

Thin Load Cells
Multiforce Sensors

500 N to 3 kN



See page 37

For tank and hopper

LCTB-A

Thin Load Cells
Multiforce Sensors

5 to 50 kN



See page 38

For tank and hopper

LCTE-A

Thin Load Cells
Multiforce Sensors

10 to 100 kN



See page 39

For tank and hopper

LCTD-A

Thin Load Cells
Multiforce Sensors

100 to 300 kN



See page 40

Load Cells (Load Transducers) For Incorporation into Equipment

Load Cell for Injection Molding Machines



See page 76

Small-Sized Compression Load Cells

12 mm dia., 4 mm thick (5 to 50 N)

LMA-A

5 N to 1 kN

Ultra-miniature

Lightweight

Affordable prices

Suitable for load distribution measurement

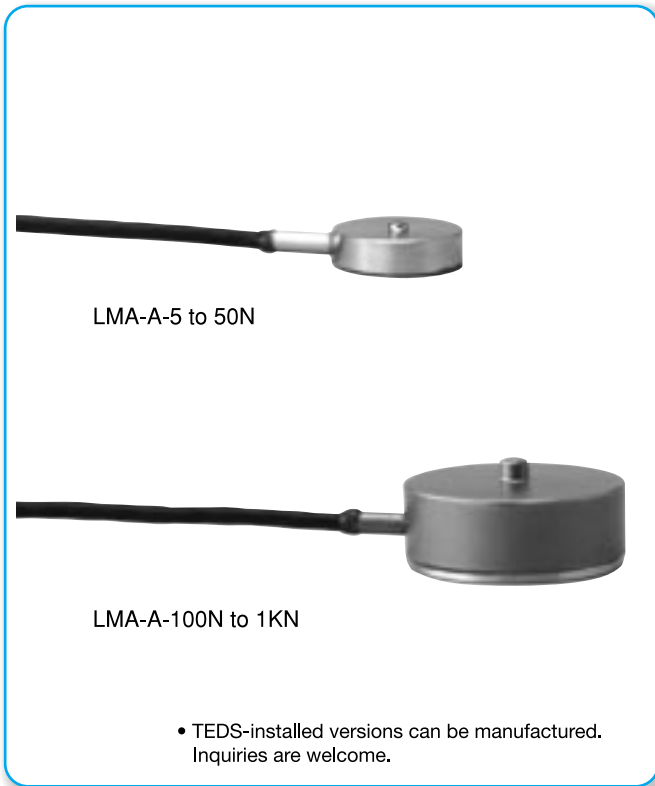

Compact and lightweight load cells in the LMA-A series can be used by merely putting or bonding on the subject site or setting in a hollow.

Specifications

Performance	
Rated Capacity	See table below.
Nonlinearity	Within $\pm 1\%$ RO
Hysteresis	Within $\pm 1\%$ RO
Repeatability	1% RO or less
Rated Output	0.75 to 2 mV/V (1500 to 4000 $\mu\text{m/m}$) 5 N: 0.6 to 2 mV/V (1200 to 4000 $\mu\text{m/m}$)

Note: Rated output is sorted to one of the classes divided by every 2% difference in output value. Since the rated output stated in the Test Data Sheet is the center value of the class, it may have a maximum error of $\pm 1\%$.

Environmental Capability	
Safe Temp. Range	-10 to 60°C
Comp. Temp. Range	0 to 50°C
Temp. Effect on Zero Bal.	Within $\pm 0.05\%$ RO/ $^\circ\text{C}$ (5 N: Within $\pm 0.3\%$ RO/ $^\circ\text{C}$, 10 to 50 N: Within $\pm 0.2\%$ RO/ $^\circ\text{C}$)
Temp. Effect on Out.	Within $\pm 0.05\%$ / $^\circ\text{C}$ (5 to 50 N: $\pm 0.2\%$ / $^\circ\text{C}$)

Electrical Characteristics	
Safe Excit. Voltage	7 V AC or DC
Recom. Excit. Voltage	1 to 5 V AC or DC
Input Resistance	$350 \Omega \pm 2.5\%$
Output Resistance	$350 \Omega \pm 2.5\%$
Cable	4-conductor (0.035 mm ²) vinyl shielded cable 1.7 mm diameter by 2 m long, bared at the tip (Shield wire is not connected to the mainframe.)

Mechanical Properties	
Safe Overload Rating	150%
Natural Frequency	See table below.
Weight	See table below.
Protection Rating	IP 64 (Sprashproof type conforming to JIS C 0920)
Enclosure	Copper alloy, 100 N or larger: Stainless steel

Option Mount Base CFM-A

Mount Base CFM-A

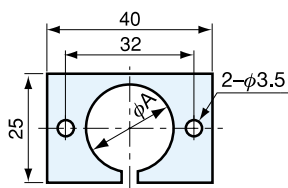

Model	ϕA	Thickness
CFM-5A	12.2	1.5
CFM-100A	20.2	3.0

Model	Rated Capacity	Nat. Freq. (App.)	Weight (App.)	Mount Base
LMA-A-5N	5 N	15.3 kHz	13 g including cable	CFM-5A
LMA-A-10N	10 N	17.5 kHz		
LMA-A-20N	20 N	24.8 kHz		
LMA-A-50N	50 N	32.6 kHz	23 g including cable	CFM-100A
LMA-A-100N	100 N	21.6 kHz		
LMA-A-200N	200 N	29.7 kHz		
LMA-A-500N	500 N	43.9 kHz		
LMA-A-1KN	1 kN	53 kHz		

Dimensions

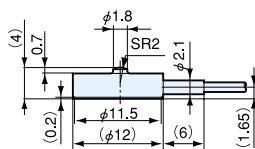

LMA-A-5 to 50N

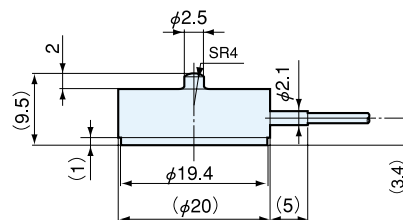

LMA-A-100N to 1KN

Small-Sized Compression Load Cells

10 mm dia., 4 mm thick

LMB-A

10 N to 2 kN

Ultra-miniature

Lightweight

Low price

Suitable for load distribution measurement



LMB-A-10N to 200N



LMB-A-500N to 2KN

- TEDS-installed versions can be manufactured. Inquiries are welcome.

Compact and lightweight load cells in the LMB-A series can be used by merely putting or bonding on the subject site or setting in a hollow.

Specifications

Performance	
Rated Capacity	See table below.
Nonlinearity	Within $\pm 0.5\%$ RO
Hysteresis	Within $\pm 0.5\%$ RO
Repeatability	Within 0.3% RO
Rated Output	10N: 0.5 mV/V (1000 $\mu\text{m}/\text{m}$) or more 50N to 2KN: 1.4 mV/V (2800 $\mu\text{m}/\text{m}$) or more

Note: Rated output is sorted to one of the classes divided by every 2% difference in output value. Since the rated output stated in the Test Data Sheet is the center value of the class, it may have a maximum error of $\pm 1\%$.

Environmental Capability	
Safe Temp. Range	-10 to 80°C (noncondensing)
Comp. Temp. Range	0 to 70°C (noncondensing)
Temp. Effect on Zero Bal.	Within $\pm 0.05\%$ RO/ $^\circ\text{C}$ (10 N: Within $\pm 0.2\%$ RO/ $^\circ\text{C}$) (50 N: Within $\pm 0.1\%$ RO/ $^\circ\text{C}$)
Temp. Effect on Out.	10N: Within $\pm 0.1\%$ / $^\circ\text{C}$ 50N to 2KN: Within $\pm 0.05\%$ / $^\circ\text{C}$

Electrical Characteristics	
Safe Excit. Voltage	7 V AC or DC
Recom. Excit. Voltage	1 to 5 V AC or DC
Input Resistance	$350 \Omega \pm 2.5\%$
Output Resistance	$350 \Omega \pm 2.5\%$
Cable	4-conductor (0.035 mm ²) vinyl shielded cable 1.7 mm diameter by 2 m long, bared at the tip (Shield wire is not connected to the mainframe.)

Mechanical Properties	
Safe Overload Rating	150%
Natural Frequency	See table below.
Spring Constant	See table below.
Weight	50 to 200 N: Approx. 1.5 g (excluding cable) 500 N to 2 kN: Approx. 7 g (excluding cable)
Protection Rating	Approximately equivalent to IP 64

Model	Rated Capacity	Nat. Freq. (App.)	Spring Constant (App.)
LMB-A-10N	10 N	32 kHz	1.5 kN/mm
LMB-A-50N	50 N	40 kHz	2.4 kN/mm
LMB-A-100N	100 N	47 kHz	4.5 kN/mm
LMB-A-200N	200 N	59 kHz	8.8 kN/mm
LMB-A-500N	500 N	37 kHz	16 kN/mm
LMB-A-1KN	1 kN	45 kHz	26 kN/mm
LMB-A-2KN	2 kN	54 kHz	41 kN/mm

Dimensions

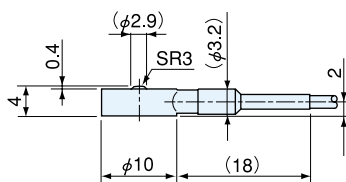

LMB-A-10N to 200N

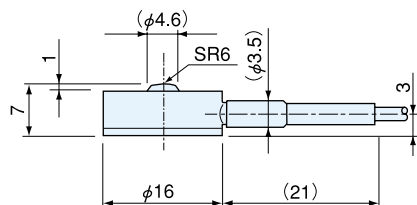

LMB-A-500N to 2KN

Small-Sized Compression Load Cells

10 mm dia., 4 mm thick

LMBT-A

50 N to 2 kN

Ultra-miniature

Lightweight

For high temp.

Suitable for load distribution measurement

NEW



LMBT-A-50N to 200N



LMBT-A-500N to 2kN

- TEDS-installed versions can be manufactured. Inquiries are welcome.

Compact and lightweight load cells in the LMBT-A series can be used by merely putting or bonding on the subject site or setting in a hollow.

Specifications

Performance	
Rated Capacity	See table below.
Nonlinearity	Within $\pm 0.3\%$ RO
Hysteresis	Within $\pm 0.3\%$ RO
Repeatability	Within 0.3% RO
Rated Output	1.4 mV/V (2800 $\mu\text{m/m}$) or more
Environmental Capability	
Safe Temp. Range	-20 to 120°C (noncondensing)
Comp. Temp. Range	-10 to 100°C (noncondensing, excluding the nameplate)
Temp. Effect on Zero Bal.	Within $\pm 0.05\%$ RO/°C
Temp. Effect on Out.	Within $\pm 0.05\%$ /°C
Electrical Characteristics	
Safe Excit. Voltage	7 V AC or DC
Recom. Excit. Voltage	1 to 5 V AC or DC
Input Resistance	350 $\Omega \pm 2.5\%$
Output Resistance	350 $\Omega \pm 2.5\%$
Cable	4-conductor (0.035 mm ²) fluoroplastics shielded cable 1.8 mm diameter by 2 m long, bared at the tip (Shield wire is not connected to the mainframe.)
Mechanical Properties	
Safe Overload Rating	150%
Natural Frequency	See table below.
Spring Constant	See table below.
Weight	50 to 200 N: Approx. 1.5 g (excluding cable) 500 N to 2 kN: Approx. 7 g (excluding cable)
Protection Rating	Approximately equivalent to IP 64

Model	Rated Capacity	Nat. Freq. (App.)	Spring Constant (App.)
LMBT-A-50N	50 N	40 kHz	2.4 kN/mm
LMBT-A-100N	100 N	47 kHz	4.5 kN/mm
LMBT-A-200N	200 N	59 kHz	8.8 kN/mm
LMBT-A-500N	500 N	37 kHz	16 kN/mm
LMBT-A-1kN	1 kN	45 kHz	26 kN/mm
LMBT-A-2kN	2 kN	54 kHz	41 kN/mm

Dimensions

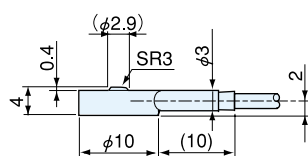

LMBT-A-50N to 200N

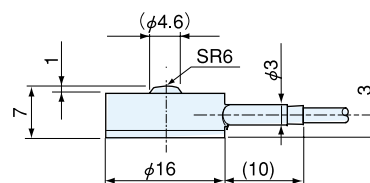

LMBT-A-500N to 2kN

Small-Sized Compression Load Cells

21 mm dia., 10 mm thick

LMR-S-SA2

2 to 20 kN

Compact

Lightweight

Affordable prices

Suitable for load distribution measurement

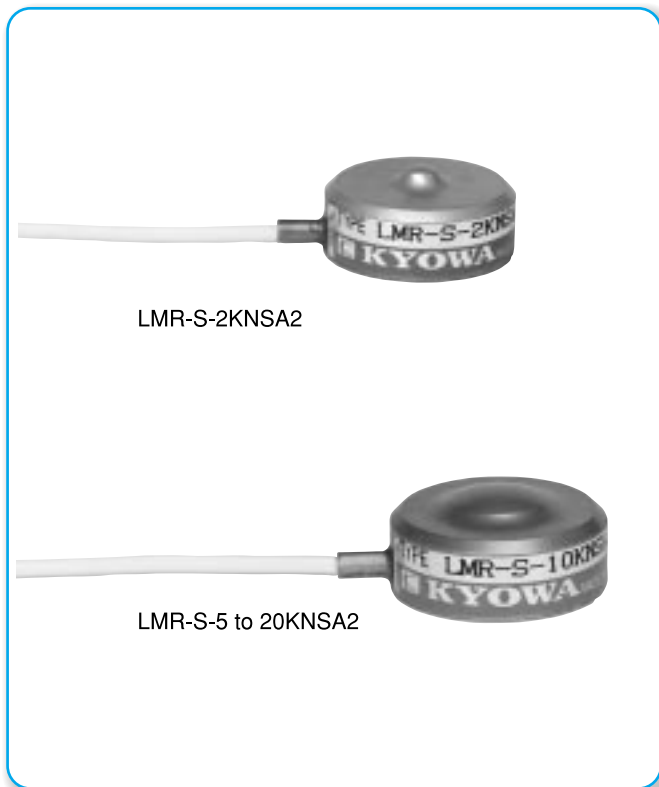

Compact and lightweight load cells in the LMR-S-SA2 series can be used by merely putting or bonding on the subject site or setting in a hollow. Major applications include measurement of load distribution by using multiple units and measurement of the load applied in making pipes or where a measuring site or the mass of load cell itself is limited.

Specifications

Performance	
Rated Capacity	See table below.
Nonlinearity	Within $\pm 1\%$ RO (20KNSA2: Within $\pm 2\%$ RO)
Hysteresis	Within $\pm 1\%$ RO (20KNSA2: Within $\pm 2\%$ RO)
Repeatability	1% RO or less
Rated Output	1 mV/V (2000 $\mu\text{m/m}$) or more
Environmental Capability	
Safe Temp. Range	-10 to 60°C
Comp. Temp. Range	0 to 50°C
Temp. Effect on Zero Bal.	Within $\pm 0.05\%$ RO/ $^\circ\text{C}$
Temp. Effect on Out.	Within $\pm 0.05\%$ / $^\circ\text{C}$
Electrical Characteristics	
Safe Excit. Voltage	7 V AC or DC
Recom. Excit. Voltage	1 to 2 V AC or DC
Input Resistance	$350\ \Omega \pm 2\%$
Output Resistance	$350\ \Omega \pm 2\%$
Cable	4-conductor (0.035 mm ²) heat-resistant vinyl shielded cable 1.7 mm diameter by 2 m long, bared at the tip (Shield wire is not connected to the mainframe.)
Mechanical Properties	
Safe Overload Rating	120%
Natural Frequency	See table below.
Weight	See table below.
Protection Rating	IP 64 (Sprashproof type conforming to JIS C 0920)
Enclosure	Stainless steel

Model	Rated Capacity	Nat. Freq. (App.)	Weight (App.)
LMR-S-2KNSA2	2 kN	50 kHz	25 g
LMR-S-5KNSA2	5 kN		
LMR-S-10KNSA2	10 kN		
LMR-S-20KNSA2	20 kN		

Users should be cautioned that operating conditions may adversely affect the stated specifications.

Dimensions

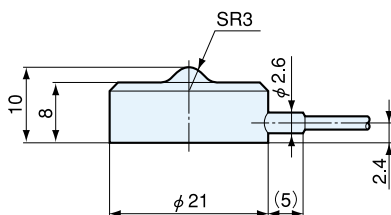

LMR-S-2KNSA2

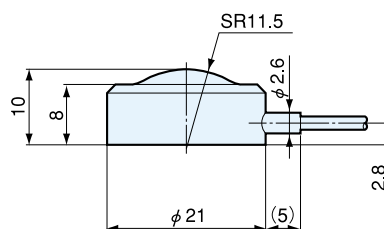

LMR-S-5 to 20KNSA2

Small-Sized Compression Load Cells

Compact, Stainless Steel Case

LCN-A

500 N to 20 kN

Compact, Lightweight

Corrosion Resistant

Hermetically Sealed Structure with Inert Gas Fill in



• TEDS-installed versions can be manufactured. Inquiries are welcome.

Since load cells in the LCN-A series are compact and lightweight, they can be easily installed to existing facilities. Their hermetically-sealed structure with inert gas filled in ensures the stable and reliable performance. In addition, the stainless steel enclosure makes them usable where corrosion resistance is required.

Specifications

Performance	
Rated Capacity	See table below.
Nonlinearity	Within $\pm 0.15\%$ RO
Hysteresis	Within $\pm 0.1\%$ RO
Repeatability	0.05% RO or less
Rated Output	2 mV/V (4000 $\mu\text{m/m}$) $\pm 0.3\%$
Environmental Capability	
Safe Temp. Range	-20 to 80°C
Comp. Temp. Range	-10 to 70°C
Temp. Effect on Zero Bal.	Within $\pm 0.005\%$ RO/°C
Temp. Effect on Out.	Within $\pm 0.01\%$ /°C
Electrical Characteristics	
Safe Excit. Voltage	20 V AC or DC
Recom. Excit. Voltage	1 to 12 V AC or DC
Input Resistance	350 $\Omega \pm 0.5\%$
Output Resistance	350 $\Omega \pm 0.5\%$
Cable	4-conductor (0.5 mm ²) chloroprene shielded cable, 8.5 mm dia. by 3 m long, with press-fit terminal for 4 mm (Shield wire is not connected to the mainframe.)
Mechanical Properties	
Safe Overload Rating	200%
Natural Frequency	See table below.
Weight	220 g
Protection Rating	IP 67 (Watertight type conforming to JIS C 0920)
Enclosure	Main unit: SUS 630, Bottom plate: SUS 304

Dimensions

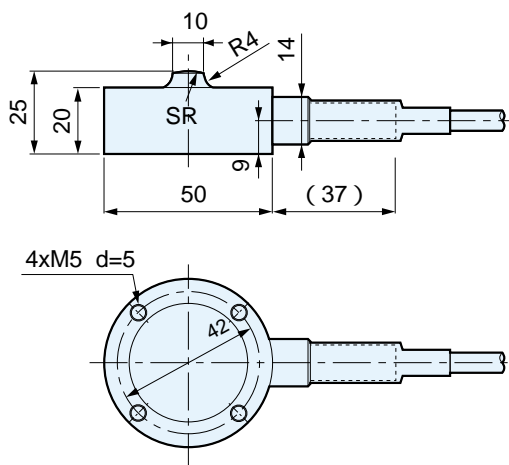

Model	SR
LCN-A-500N to 2KN	15
LCN-A-5 to 20KN	30

Model	Rated Capacity	Natural Frequency (App.)
LCN-A-500N	500 N	6.4 kHz
LCN-A-1KN	1 kN	5.3 kHz
LCN-A-2KN	2 kN	7.6 kHz
LCN-A-5KN	5 kN	13 kHz
LCN-A-10KN	10 kN	18 kHz
LCN-A-20KN	20 kN	24 kHz

Dimensions with Saddle and Mount Base Mounted

• In combination with Saddle CA and Mount Base CF

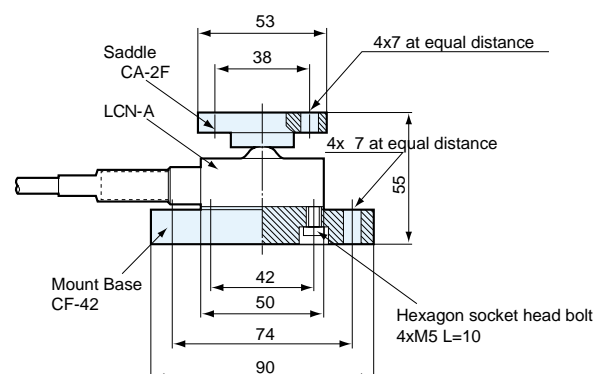

Hexagon socket head bolts to connect the load cell and the mount base are attached to the mount base.

Saddles and Mount Bases

	Saddle	Mount Base
Dedicated to LCN-A	CA-2F	CF-42
To use LCN-A in place of other models	CA-2FM1	CF-42M1
	CA-2FM2	CF-42M2
To use LCN-A in place of LCF-A*	CA-2B	CF-42M3

*To replace LCF-A with LCN-A

• Inner Plate CAI-2

The inner plate is intended to protect the load sensing part at the head of load cell. It prevents frequent application of impact load from damaging the load receiving part and making the spherical surface flat.

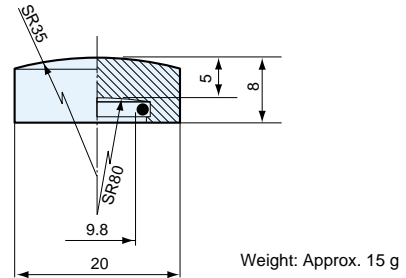
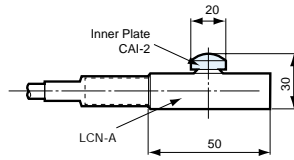

• Saddle CA-2F

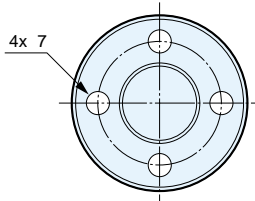
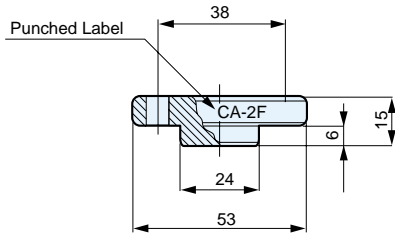

Weight: Approx. 200 g

• Saddle CA-2B for Alternate Use of LCF-A and LCN-A

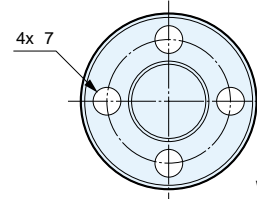
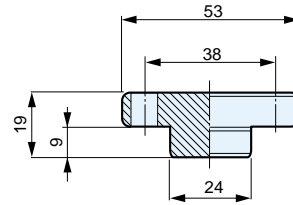

Weight: Approx. 200 g

• Mount Base CF-42

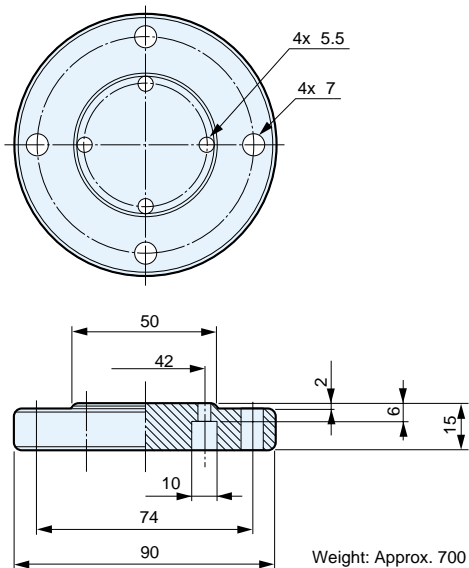

• Mount Base CF-42M3 for Alternate Use of LCF-A and LCN-A

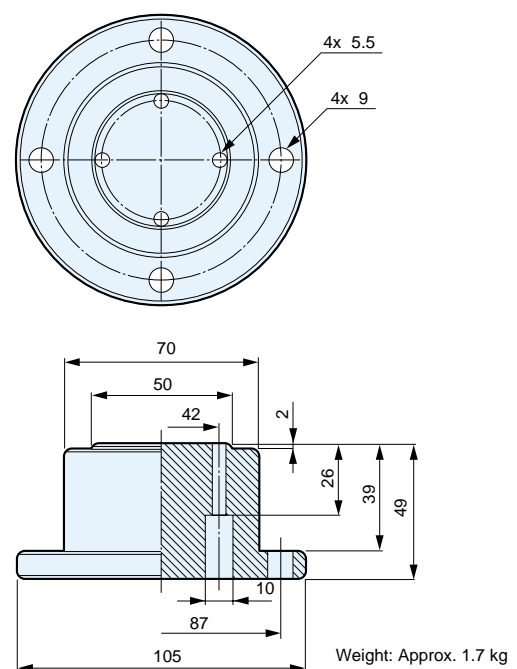

Small-Sized Compression Load Cells

Compact, Lightweight and Thin

LCX-A-ID

500 N to 20 kN

28 mm ϕ , 18 mm Thick (500 N to 2 kN)

Stainless Steel Case

TEDS Installed



LCX-A-5KN to 20KN



LCX-A-500N to 2KN

Load cells in the LCX-A-ID series are compact and lightweight, facilitating incorporation into equipment. The connector-integrated design ensures easy installation without worrying about cable handling as well as easy replacement of cable.

Specifications

Performance	
Rated Capacity	See table below.
Nonlinearity	Within $\pm 0.1\%$ RO
Hysteresis	Within $\pm 0.1\%$ RO
Repeatability	0.05% RO or less
Rated Output	1.0 mV/V (2000 $\mu\text{m/m}$) or more (500N) 1.5 mV/V (3000 $\mu\text{m/m}$) or more (1KN to 20KN)
Environmental Capability	
Safe Temp. Range	-20 to 80°C
Comp. Temp. Range	-10 to 70°C
Temp. Effect on Zero Bal.	Within $\pm 0.005\%$ RO/ $^\circ\text{C}$ (1KN to 20KN) Within $\pm 0.01\%$ RO/ $^\circ\text{C}$ (500N)
Temp. Effect on Out.	Within $\pm 0.005\%$ / $^\circ\text{C}$
Electrical Characteristics	
Safe Excit. Voltage	15 V AC or DC
Recom. Excit. Voltage	1 to 10 V AC or DC
Input Resistance	375 $\Omega \pm 5 \Omega$
Output Resistance	350 $\Omega \pm 3.5 \Omega$
Cable	6-conductor (0.08 mm ²) chloroprene shielded cable, 4.4 mm dia. by 3 m long, with connector plug to load cell and bared to amplifier (Shield wire is not connected to the mainframe.)
Mechanical Properties	
Safe Overload Rating	150%
Safe Lateral Load	15% the rated capacity
Natural Frequency	See table below.
Enclosure	SUS, metallic finish
Weight	Approx. 45 g (500N to 2KN), excluding cable Approx. 120 g (5KN to 200KN), excluding cable
Protection Rating	IP 67 (Watertight type conforming to JIS C 0920)

Model	Rated Capacity	Natural Freq. (App.)	Spring Constant (App.)
LCX-A-500N-ID	500 N	24 kHz	13 kN/mm
LCX-A-1KN-ID	1 kN	29 kHz	23 kN/mm
LCX-A-2KN-ID	2 kN	37 kHz	38 kN/mm
LCX-A-5KN-ID	5 kN	24 kHz	74 kN/mm
LCX-A-10KN-ID	10 kN	28 kHz	109 kN/mm
LCX-A-20KN-ID	20 kN	37 kHz	190 kN/mm

Dimensions

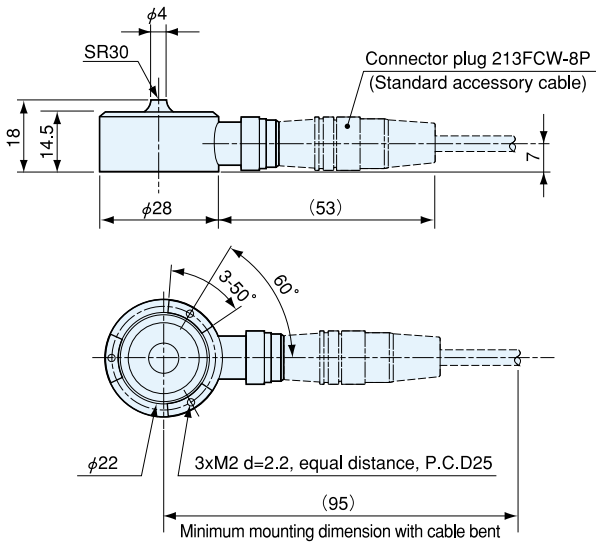

LCX-A-500N, 1KN, 2 KN-ID

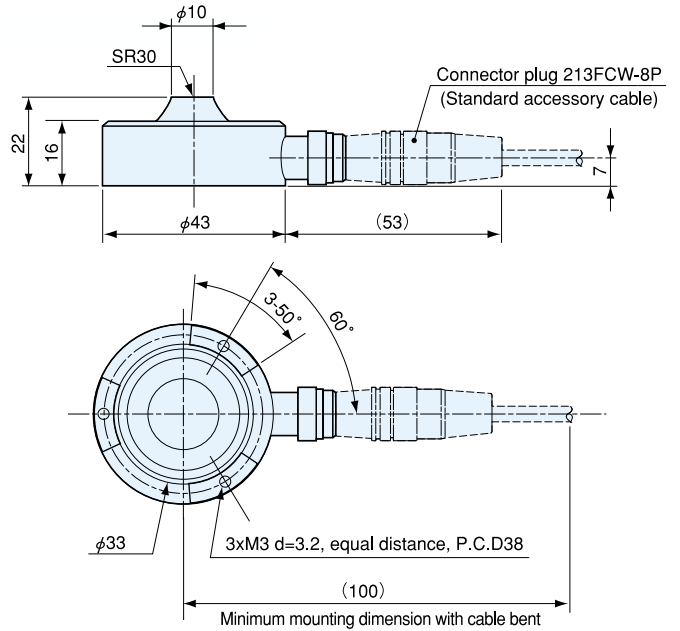

LCX-A-5KN, 10KN, 20KN-ID

Dimensions with Saddle and Mount Base Mounted

● In Combination with Saddle CA and Mount Base CX

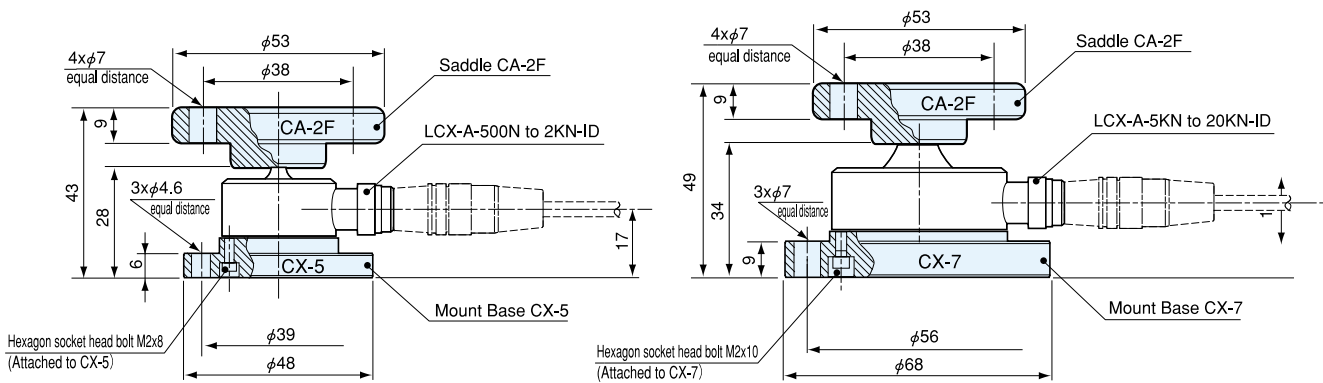

Dimensions of Mount Base

● Mount Base CX-5

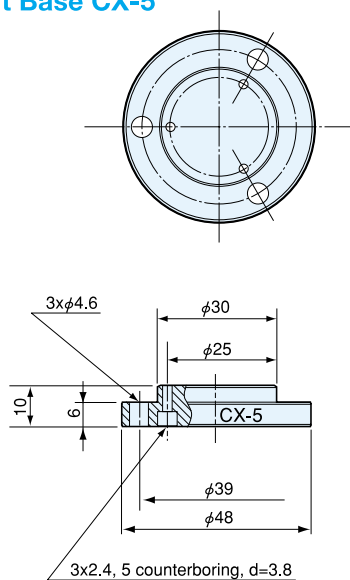

● Mount Base CX-7

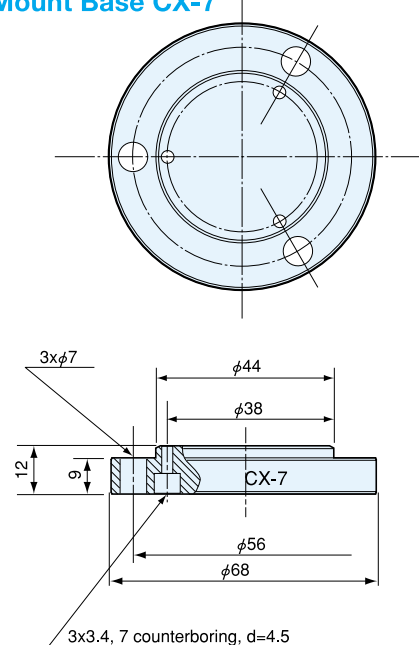

Small-Sized Large-Capacity Compression Load Cells

20 & 25 mm ϕ

LCR-G-SA2

5 to 50 kN

Compact

Lightweight

Large Capacity



Load cells in the LCR-G-SA2 series feature a small outer diameter and have the cable coming from the bottom. Thus, they can be inserted into a cylindrical object for measurement.

Specifications

Performance	
Rated Capacity	See table below.
Nonlinearity	Within $\pm 1\%$ RO
Hysteresis	Within $\pm 1\%$ RO
Rated Output	1 mV/V (2000 $\mu\text{m/m}$) or more
Environmental Capability	
Safe Temp. Range	-10 to 70°C
Comp. Temp. Range	0 to 60°C
Temp. Effect on Zero Bal.	Within $\pm 0.1\%$ RO/°C
Temp. Effect on Out.	Within $\pm 0.05\%$ /°C
Electrical Characteristics	
Safe Excit. Voltage	7 V AC or DC
Recom. Excit. Voltage	1 to 2 V AC or DC
Input Resistance	350 $\Omega \pm 5\%$
Output Resistance	350 $\Omega \pm 5\%$
Cable	4-conductor (0.05 mm ²) chloroprene shielded cable, 3 mm dia. by 5 m long, terminated with NDIS connector plug (Shield wire is not connected to the mainframe.)
Mechanical Properties	
Safe Overload Rating	120%
Weight	See table below.
Protection Rating	IP 64 (Splashproof type conforming to JIS C 0920)
Enclosure	SUS, metallic finish

Dimensions

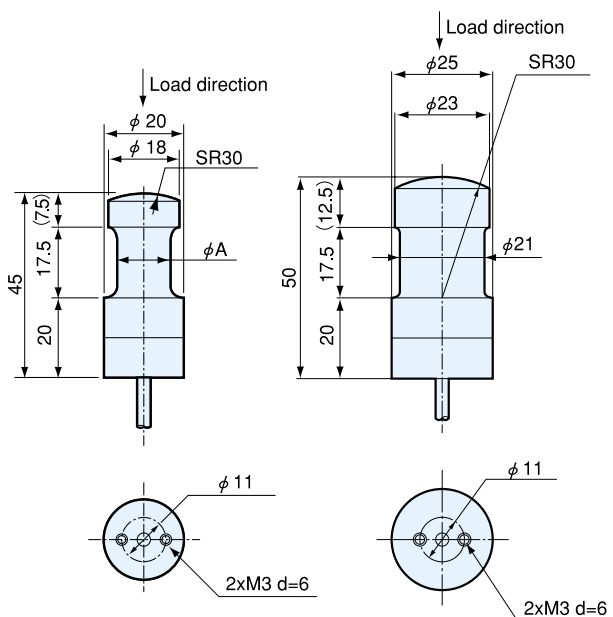

LCR-G-5 to 30KNSA2

LCR-G-50KNSA2

Model	Rated Capacity	Weight (App.)
LCR-G-5KNSA2	5 kN	100 g
LCR-G-10KNSA2	10 kN	
LCR-G-20KNSA2	20 kN	
LCR-G-30KNSA2	30 kN	
LCR-G-50KNSA2	50 kN	130 g

Model	ϕA
LCR-G-5KNSA2	9.2
LCR-G-10KNSA2	11
LCR-G-20KNSA2	14
LCR-G-30KNSA2	16.5

LC-V

50 to 200 kN

Compact, Lightweight

Nonlinearity 1/2000

Hermetically Sealed Structure with Inert Gas Filled in

Fatigue Life $\geq 1 \times 10^7$

BISELCOM Gage Used



• TEDS-installed versions can be manufactured. Inquiries are welcome.

• Steady brace CR is available. (See page 27.)

Since load cells in the LC-V series are compact and lightweight, they can be easily installed to existing facilities. Their hermetically-sealed structure filled with inert gas ensures the stable and reliable performance while maintaining accuracy as high as 1/2000.

Specifications

Performance									
Rated Capacity	See table below.								
Nonlinearity	Within $\pm 0.05\%$ RO								
Hysteresis	Within $\pm 0.05\%$ RO								
Repeatability	0.03% RO or less								
Rated Output	2.5 mV/V (5000 $\mu\text{m/m}$) $\pm 0.2\%$								
Environmental Capability									
Safe Temp. Range	-20 to 80°C								
Comp. Temp. Range	-10 to 70°C								
Temp. Effect on Zero Bal.	Within $\pm 0.003\%$ RO/°C								
Temp. Effect on Out.	Within $\pm 0.003\%$ /°C								
Electrical Characteristics									
Safe Excit. Voltage	20 V AC or DC								
Recom. Excit. Voltage	1 to 10 V AC or DC								
Input Resistance	350 $\Omega \pm 0.5\%$								
Output Resistance	350 $\Omega \pm 0.5\%$								
Cable	4-conductor (0.5 mm ²) chloroprene shielded cable, 8.5 mm dia. by 5 m long, with a press-fit terminal for 4 mm (Shield wire is not connected to the mainframe.)								
Mechanical Properties									
Safe Overload Rating	150%								
Natural Frequency	<table border="1"> <thead> <tr> <th>Model</th> <th>Natural Frequency (Approx.)</th> </tr> </thead> <tbody> <tr> <td>LC-5TV</td> <td>17 kHz</td> </tr> <tr> <td>LC-10TV</td> <td>16 kHz</td> </tr> <tr> <td>LC-20TV</td> <td>15 kHz</td> </tr> </tbody> </table>	Model	Natural Frequency (Approx.)	LC-5TV	17 kHz	LC-10TV	16 kHz	LC-20TV	15 kHz
Model	Natural Frequency (Approx.)								
LC-5TV	17 kHz								
LC-10TV	16 kHz								
LC-20TV	15 kHz								
Weight	See table below.								
Protection Rating	IP 67 (Watertight type conforming to JIS C 0920)								

Dimensions

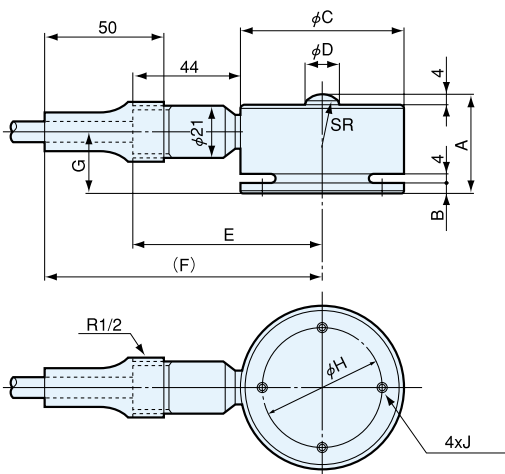

Model	Rated Capacity	A	B	ϕC	ϕD	E	F	G	ϕH	J	R	Weight (App.)
LC-5TV	50kN	40	4	68	14	78	114	25	50	M5	40	1.0 kg
LC-10TV	100kN	45	5	78	20	83	119	29	60	M6	70	1.3 kg
LC-20TV	200kN	55	6	98	26	93	129	36	80	M8	120	3.1 kg

Dimensions with Accessories Mounted

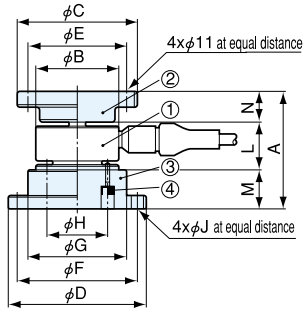

● In Combination with Saddle CA and Mount Base CF

Load Cell Proper ①	Saddle ②	Mount Base ③	Hexagon Socket Head Cap Screw ④	A	B	φC	φD	φE	φF	φG	φH	φJ	L	M	N
LC-5TV	CA-10B	CF-50	4-M5 L=20	94	68	98	112	80	96	80	50	9	40	30	24
LC-10TV	CA-10B	CF-60	4-M6 L=20	99	78	98	122	80	106	90	60	9	45	30	24
LC-20TV	CA-50B	CF-80	4-M8 L=25	123	98	118	148	100	124	100	80	13	55	40	28

Hexagon socket head cap screw is attached to the mount base for its connection to the load cell.

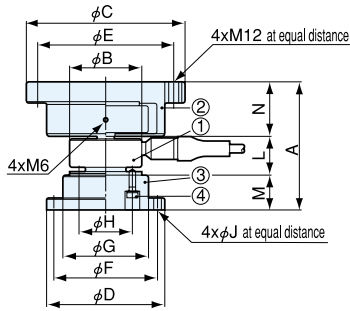

● In Combination with Movable Saddle ER and Mount Base CF

Load Cell Proper ①	Movable Saddle ②	Mount Base ③	Hexagon Socket Head Cap Screw ④	A	B	φC	φD	φE	φF	φG	φH	φJ	L	M	N
LC-5TV	ER-5B	CF-50	4-M5 L=20	119	68	148	112	128	96	80	50	9	40	30	49
LC-10TV	ER-10B	CF-60	4-M6 L=20	134	78	178	122	158	106	90	60	9	45	30	59
LC-20TV	ER-20B	CF-80	4-M8 L=25	173	98	198	148	178	124	100	80	13	55	40	78

Hexagon socket head cap screw is attached to the mount base for its connection to the load cell.

Dimensions in Combination with Mount Bases for Model Change

● These mount bases are used to replace LC-E, LCF-A (LC-F) or LC-G with LC-V.

● Mount Base CFS-E to Replace LC-E with LC-V

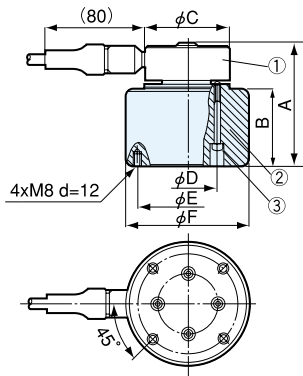

Load Cell Proper ①	Mount Base ②	Hexagon Socket Head Cap Screw ③	A	B	φC	φD	φE	φF
LC-5TV	CFS-5E	4-M5 L=50	103	63	68	50	80	100
LC-10TV	CFS-10E	4-M6 L=50	103	58	78	60	80	100
LC-20TV	CFS-20E	4-M8 L=50	110	55	98	80	90	120

Hexagon socket head cap screw is attached to the mount base for its connection to the load cell.

● Mount Base CFS-F to Replace LCF-A with LC-V

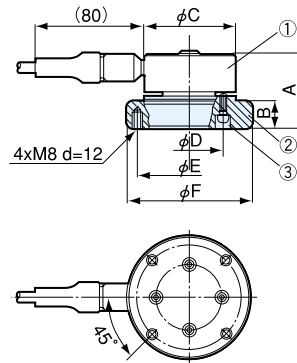

Load Cell Proper ①	Mount Base ②	Hexagon Socket Head Cap Screw ③	A	B	φC	φD	φE	φF
LC-5TV	CFS-5F	4-M5 L=16	60	20	68	50	80	96
LC-10TV	CFS-10F	4-M6 L=25	75	30	78	60	100	116
LC-20TV	CFS-20F	4-M8 L=35	95	40	98	80	130	156

Hexagon socket head cap screw is attached to the mount base for its connection to the load cell.

● Mount Base CFS-G to Replace LC-G with LC-V

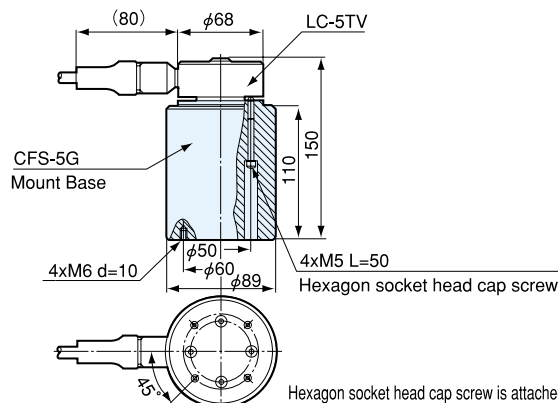

Hexagon socket head cap screw is attached to the mount base for its connection to the load cell.

Special Accessories

Steady Braces CR Series



The steady brace is used in place of a saddle and mount base when installing a load cell to a hopper scale. It eliminates the need to prepare a rolling prevention mechanism such as check rod.

Features

- Reductions in construction time and investment are ensured since designing and construction for rolling prevention are not required.
- Enables installation of a load cell in small space.
- Easy installation to equipment

Dimensions in Combination with Load Cell

• Steady Brace CR in Combination with LC-V

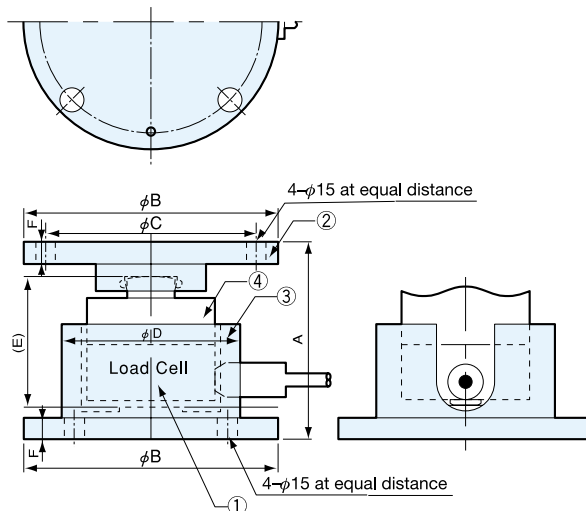

Load Cell Proper ①	Steady Brace ②, ③, ④	A	φB	φC	φD	E	F	Weight (App.)
LC-5TV	CR-5	120	148	126	96	80	13	7 kg
LC-10TV	CR-10	120	158	136	110	80	13	8.5 kg
LC-20TV	CR-20	145	187	164	136	95	15	15.6 kg

Installation Sample

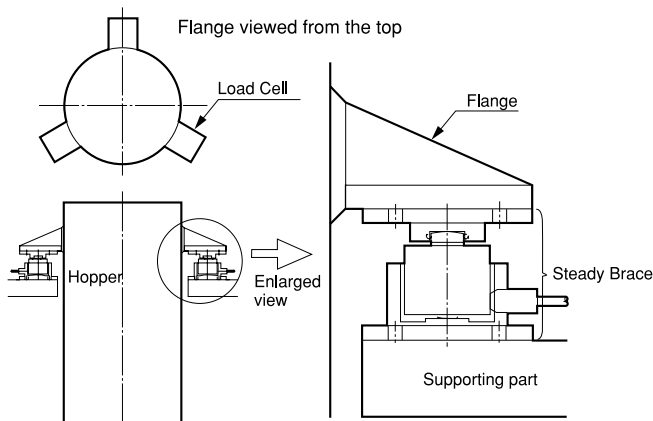

Behavior of Steady Brace against Lateral Load

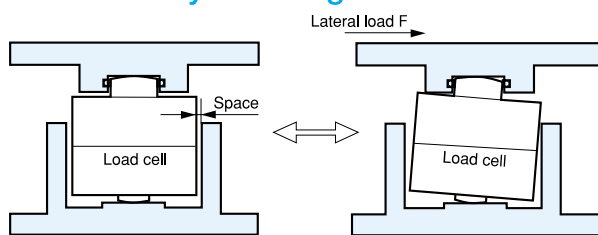

Fig. 1 Normal Status

Fig. 2 With lateral load applied

When a lateral load is applied in the status shown in Fig. 1, the load cell inside the assembly is inclined and the upper part of steady brace moves to the right (see Fig. 2).
When the lateral load is removed, the status shown in Fig. 1 returns.

For safe operation

To prevent the hopper from falling down, the hopper's center of gravity should be low enough from the installation position of load cell.

Small-Sized Compression Load Cells

Compact but Large Rated Capacity

LCV-A

500 kN, 1 MN

Compact, Lightweight

Nonlinearity 1/1000

Fatigue Life $\geq 1 \times 10^7$

BISELCOM Gage Used



• TEDS-installed versions can be manufactured. Inquiries are welcome.

LCV-A series is compact and lightweight load cells developed for large capacities of 500 kN and 1 MN. They can easily be installed into existing facilities. The hermetically-sealed structure with inert gas filled in ensures stable and reliable performance with 1/1000 accuracy. Use of BISELCOM gage ensures increased output and improved reliability.

Specifications

Performance										
Rated Capacity	See table below.									
Nonlinearity	Within $\pm 0.1\%$ RO									
Hysteresis	Within $\pm 0.1\%$ RO									
Repeatability	0.05% RO or less									
Rated Output	2.5 mV/V (5000 $\mu\text{m/m}$) $\pm 0.2\%$									
Environmental Capability										
Safe Temp. Range	-20 to 80°C									
Comp. Temp. Range	-10 to 70°C									
Temp. Effect on Zero Bal.	Within $\pm 0.005\%$ RO/°C									
Temp. Effect on Out.	Within $\pm 0.005\%$ /°C									
Electrical Characteristics										
Safe Excit. Voltage	20 V AC or DC									
Recom. Excit. Voltage	1 to 10 V AC or DC									
Input Resistance	350 $\Omega \pm 0.5\%$									
Output Resistance	350 $\Omega \pm 0.5\%$									
Cable	4-conductor (0.5 mm ²) chloroprene shielded cable, 8.5 mm dia. by 5 m long, with a press-fit terminal for 4 mm (Shield wire is not connected to the mainframe.)									
Mechanical Properties										
Safe Overload Rating	150%									
Natural Frequency	<table border="1"> <thead> <tr> <th>Model</th> <th>Nat. Freq. (App.)</th> <th>Weight (App.)</th> </tr> </thead> <tbody> <tr> <td>LCV-A-500KN</td> <td>13 kHz</td> <td>6 kg</td> </tr> <tr> <td>LCV-A-1MN</td> <td>12 kHz</td> <td>11 kg</td> </tr> </tbody> </table>	Model	Nat. Freq. (App.)	Weight (App.)	LCV-A-500KN	13 kHz	6 kg	LCV-A-1MN	12 kHz	11 kg
Model	Nat. Freq. (App.)	Weight (App.)								
LCV-A-500KN	13 kHz	6 kg								
LCV-A-1MN	12 kHz	11 kg								
Protection Rating	IP 67 (Watertight type conforming to JIS C 0920)									

Dimensions

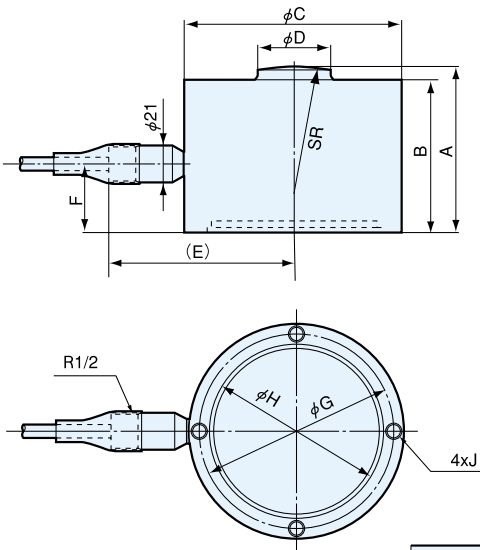

Model	Rated Capacity	A	B	ϕC	ϕD	E	F	ϕG	ϕH	J	R
LCV-A-500KN	500 kN	95	88	126	42	107	40	113	101	M10 d=12	125
LCV-A-1MN	1 MN	120	110	146	58	117	50	130	115	M12 d=18	180

Dimensions with Accessories Mounted

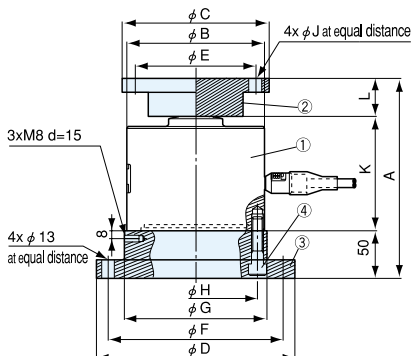

• In Combination with Saddle CA and Mount Base CF

Load Cell Proper ①	Saddle ②	Mount Base ③	Hexagon Socket Head Cap Screw ④	A	ϕB	ϕC	ϕD	ϕE	ϕF	ϕG	ϕH	ϕJ	K	L
LCV-A-500KN	CA-50B	CF-113F	4-M10 L=45	173	126	118	178	100	154	130	113	11	95	28
LCV-A-1MN	CA-1MH	CF-130F	4-M12 L=50	210	146	156	208	128	184	150	130	13	120	40

Hexagon socket head cap screw is attached to the mount base for its connection to the load cell.

General-Purpose Compression Load Cells

Large Rated Capacity

LC-E Made to order

2, 5 MN

Highly Stable

Hermetically Sealed Structure with Inert Gas Filled in



• Watertight versions conforming to JIS C 0920 can be manufactured.

Load cells in the LC-E series feature the detecting part in which inert gas is sealed to prevent aging deterioration while ensuring reliable, stable operation.

Specifications

Performance	
Rated Capacity	See table below.
Nonlinearity	Within $\pm 0.5\%$ RO
Hysteresis	Within $\pm 0.2\%$ RO
Repeatability	0.1% RO or less
Rated Output	2 mV/V (4000 $\mu\text{m/m}$) $\pm 1\%$
Environmental Capability	
Safe Temp. Range	-30 to 85°C
Comp. Temp. Range	-10 to 70°C
Temp. Effect on Zero Bal.	Within $\pm 0.005\%$ RO/°C
Temp. Effect on Out.	Within $\pm 0.005\%$ /°C
Electrical Characteristics	
Safe Excit. Voltage	20 V AC or DC
Recom. Excit. Voltage	1 to 10 V AC or DC
Input Resistance	350 $\Omega \pm 0.5\%$
Output Resistance	350 $\Omega \pm 0.5\%$
Cable	4-conductor (0.3 mm ²) chloroprene shielded cable, 7.6 mm dia. by 5 m long, terminated with an NDIS connector plug (Shield wire is not connected to the mainframe,)
Mechanical Properties	
Safe Overload Rating	150%
Natural Frequency	Refer to table below.
Weight	Refer to table below.
Protection Rating	IP 64 (Sprashproof type conforming to JIS C 0920)

Dimensions

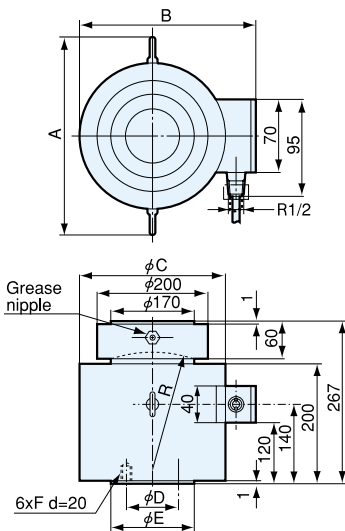

Model	Rated Capacity	Natural Frequency (App.)	A	B	ϕC	ϕD	ϕE	F	R	Weight (App.)
LC-200TE	2 MN	3.5 kHz	310	246	210	90	135	M14	180	49 kg
LC-500TE	5 MN	4 kHz	340	277	240	130	170	M16	230	65 kg

• Saddle CA-B is a standard provision.
Watertight versions conforming to JIS C 0920 can be manufactured.

Dimensions with Accessories Mounted

• In Combination with Saddle CA and Mount Base CF

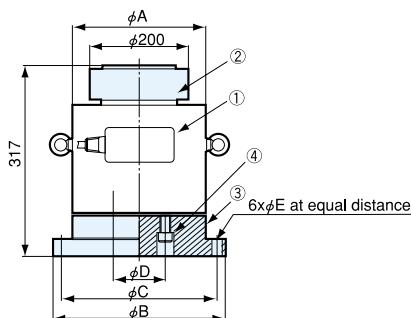

Load Cell Proper ①	Saddle ②	Mount Base ③	Hexagon Socket Head Cap Screw ④	ϕA	ϕB	ϕC	ϕD	ϕE
LC-200TE	CA-200B	CF-90E	6-M14 L=40	210	268	240	90	18
LC-500TE	CA-500B	CF-130E	6-M16 L=40	240	318	279	130	22

Hexagon socket head cap screw is attached to the mount base for its connection to the load cell.

Dimensions of Mount Base

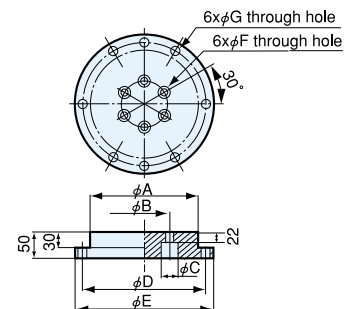

Model	Applicable Load Cell	ϕA	ϕB	ϕC	ϕD	ϕE	ϕF	ϕG
CF-90E	LC-200TE	210	90	23	240	268	16	18
CF-130E	LC-500TE	240	130	26	279	318	18	22

General-Purpose Compression Load Cells LC-E

LCH-F

100, 200 kN

Nonlinearity 1/5000

Remote Sensing Possible

Watertight Structure



• TEDS-installed versions can be manufactured. Inquiries are welcome. Note, however, that remote sensing function cannot be used for TEDS-installed versions.

Load cells in the LCH-F series perform measurement with an accuracy as high as 1/5000 even at high temperatures or under water (watertight design in conformity with JIS C 0920). For remote sensing, refer to page 3.

Specifications

Performance	
Rated Capacity	See table below.
Nonlinearity	Within $\pm 0.02\%$ RO
Hysteresis	Within $\pm 0.02\%$ RO
Repeatability	0.02% RO or less
Rated Output	2 mV/V (4000 $\mu\text{m/m}$) $\pm 0.1\%$
Environmental Capability	
Safe Temp. Range	-35 to 80°C
Comp. Temp. Range	-10 to 60°C
Temp. Effect on Zero Bal.	Within $\pm 0.0015\%$ RO/ $^\circ\text{C}$
Temp. Effect on Out.	Within $\pm 0.001\%$ / $^\circ\text{C}$
Electrical Characteristics	
Safe Excit. Voltage	20 V AC or DC
Recom. Excit. Voltage	1 to 10 V AC or DC
Input Resistance	350 $\Omega \pm 0.5\%$
Output Resistance	350 $\Omega \pm 0.5\%$
Cable	4-conductor (0.5 mm ²) chloroprene shielded cable, 9.5 mm dia. by 5 m long, with a press-fit terminal for 4 mm (Shield wire is not connected to the mainframe.)

Mechanical Properties	
Safe Overload Rating	200%
Natural Frequency	Refer to table below.
Weight	Refer to table below.
Protection Rating	IP 67 (Watertight type conforming to JIS C 0920)

Dimensions

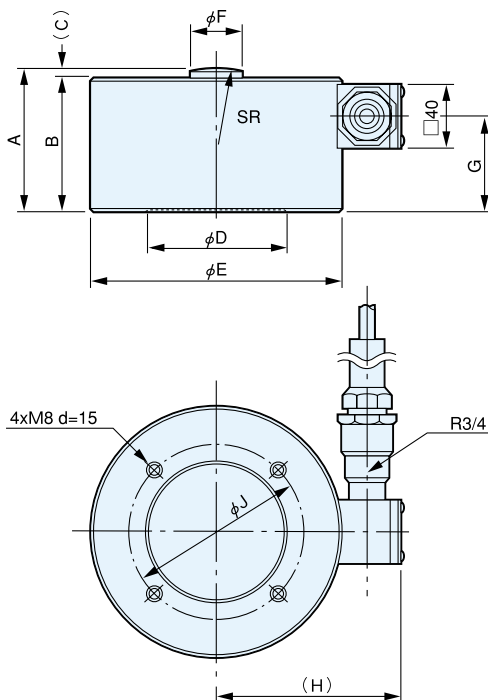

Dimensions with Accessories Mounted

• In Combination with Saddle CA and Mount Base CF

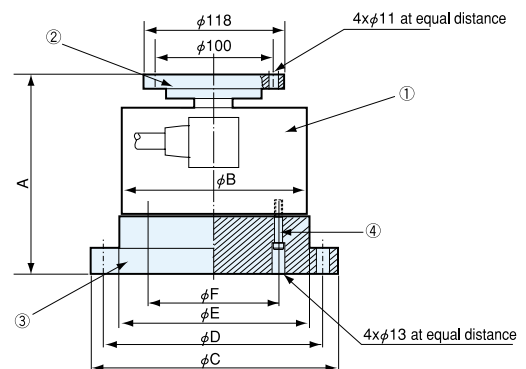

Load Cell Proper ①	Saddle ②	Mount Base ③	Hexagon Socket Head Cap Screw ④	A	ϕB	ϕC	ϕD	ϕE	ϕF
LCH-10TF	CA-50B	CF-110	4-M8 L=35	168	156	208	184	160	110
LCH-20TF	CA-50B	CF-130	4-M8 L=30	188	176	234	210	186	130

Hexagon socket head cap screw is attached to the mount base for its connection to the load cell.

Model	Rated Capacity	Natural Frequency (App.)	A	B	C	ϕD	ϕE	ϕF	G	H	ϕJ	R	Weight (App.)	Movable Saddle
LCH-10TF	100 kN	7.5 kHz	90	82	8	90	156	32	60	113.5	110	50	12 kg	ER-10B
LCH-20TF	200 kN	7 kHz	110	100	10	110	176	45	75	123.5	130	70	17 kg	ER-20B

Thin Compression Load Cells

25 mm Thick (5 to 20 kN)

LCK-A

5 to 200 kN

Thin

High Reliability

Hermetically Sealed Structure with Inert Gas Filled in



- TEDS-installed versions can be manufactured. Inquiries are welcome.

While load cells in the LCK-A series are designed to be thin for convenient installation as detection terminals of weighing systems, they are excellent in every point; accuracy, reliability, stability, and response. The thin design makes them suitable for applications where the space, especially the height, is limited or the detecting part is desired to be downsized for measurement of force or weight applied to a conveyor, hopper or tank.

Specifications

Performance	
Rated Capacity	See table below.
Nonlinearity	Within $\pm 0.2\%$ RO (200kN: Within $\pm 0.5\%$ RO)
Hysteresis	Within $\pm 0.2\%$ RO (200kN: Within $\pm 0.5\%$ RO)
Repeatability	0.05% RO or less
Rated Output	2 mV/V (4000 $\mu\text{m/m}$) $\pm 0.5\%$
Environmental Capability	
Safe Temp. Range	-30 to 80°C
Comp. Temp. Range	-10 to 70°C
Temp. Effect on Zero Bal.	Within $\pm 0.007\%$ RO/°C
Temp. Effect on Out.	Within $\pm 0.005\%$ /°C
Electrical Characteristics	
Safe Excit. Voltage	20 V AC or DC
Recom. Excit. Voltage	1 to 10 V AC or DC
Input Resistance	350 $\Omega \pm 0.5\%$
Output Resistance	350 $\Omega \pm 0.5\%$
Cable	4-conductor (0.3 mm ²) chloroprene shielded cable, 7.6 mm dia. by 5 m long, bared at the tip (Shield wire is not connected to the mainframe.)
Mechanical Properties	
Safe Overload Rating	150%
Natural Frequency	Refer to table below.
Weight	Refer to table below.
Protection Rating	IP 67 (Watertight type conforming to JIS C 0920)

Dimensions

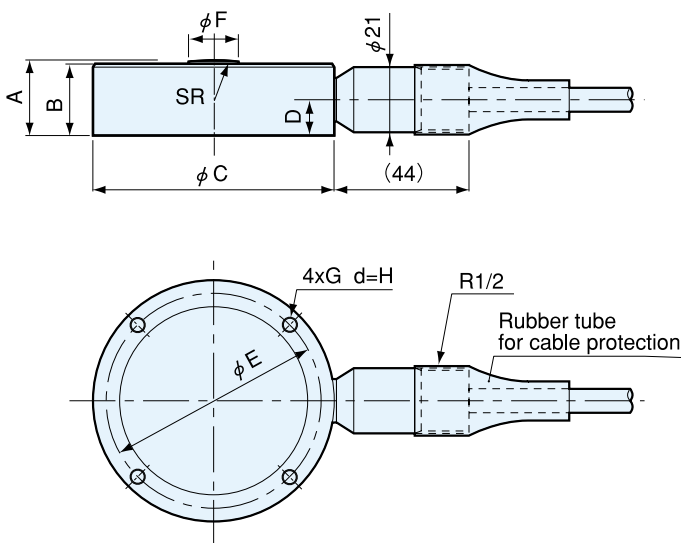

Model	Rated Capacity	Natural Frequency (App.)	A	B	ϕC	D	ϕE	ϕF	G	H	R	Weight (App.)
LCK-A-5KN	5 kN	10.7 kHz	25	23.5	78	12	70	16	M5	8	50	900g
LCK-A-10KN	10 kN	11.4 kHz										
LCK-A-20KN	20 kN	14.2 kHz										
LCK-A-50KN	50 kN	24.2 kHz	30	28	98	14.5	80	18	M8	12	70	1.8 kg
LCK-A-100KN	100 kN	14.8 kHz	35	33	108	17.5	90	25	M8	12	70	2.5 kg
LCK-A-200KN	200 kN	12.6 kHz	50	45	118	25	100	35	M8	12	100	4.1 kg

Dimensions with Accessories Mounted

● In Combination with Saddle CA and Mount Base CF

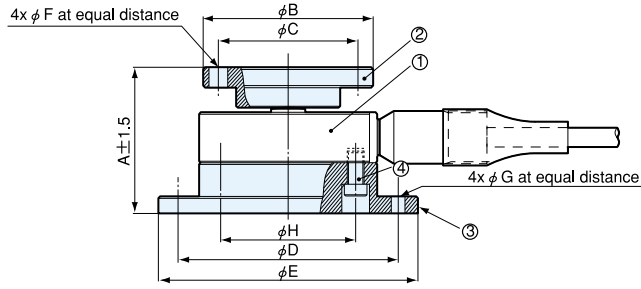

Load Cell Proper ①	Saddle ②	Mount Base ③	Hexagon Socket Head Cap Screw ④	A	φB	φC	φD	φE	φF	φG	φH
LCK-A-5KN	CA-2B	CF-70D	4-M5 L=20	74	53	38	100	116	7	9	70
LCK-A-10KN											
LCK-A-20KN											
LC -A-50KN	CA-10B	CF-80D	4-M8 L=20	84	98	80	130	154	11	13	80
LC -A-100KN	CA-10B	CF-90D	4-M8 L=20	89	98	80	140	164	11	13	90
LCK-A-200KN	CA-50B	CF-100D	4-M8 L=25	118	118	100	150	174	11	13	100

Hexagon socket head cap screw is attached to the mount base for its connection to the load cell.

Dimensions of Saddle

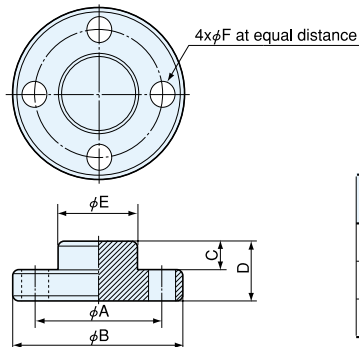

Model	φA	φB	C	D	φE	φF	Hexagon Socket Head Cap Screw	Weight (App.)
CA-2B	38	53	9	19	24	7	M6	200 g
CA-10B	80	98	12	24	60	11	M10	1 kg
CA-50B	100	118	13	28	80	11	M10	1.8 kg

Dimensions of Mount Base

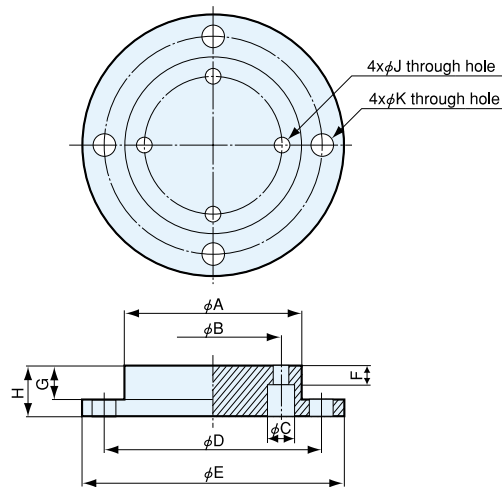

Model	φA	φB	φC	φD	φE	F	G	H	φJ	φK	Weight (App.)
CF-70D	84	70	10	100	116	13	20	30	5.5	9	
CF-80D	106	80	16	130	154	13	20	30	9	13	
CF-90D	116	90	16	140	164	13	20	30	9	13	
CF-100D	126	100	16	150	174	18	25	40	9	13	

Corrosion-Resistant Compression Load Cells

Stainless Steel

LC-J Made to order

5 to 200 kN

Corrosion-Resistant

Hermetically Sealed Structure with Inert Gas Filled in

Safe Overload Rating as High as 400%



The hermetically-sealed structure with inert gas filled in makes load cells in the LC-J series applicable for measurement in food processing or where they are exposed to strongly corrosive liquids or gases. Their high overload rating minimizes a chance of breaking down due to overload.

Specifications

Performance	
Rated Capacity	See table below.
Nonlinearity	Within $\pm 0.5\%$ RO
Hysteresis	Within $\pm 0.5\%$ RO
Repeatability	0.1% RO or less
Rated Output	1 mV/V (2000 $\mu\text{m/m}$) $\pm 0.2\%$
Environmental Capability	
Safe Temp. Range	-35 to 80°C
Comp. Temp. Range	-10 to 70°C
Temp. Effect on Zero Bal.	Within $\pm 0.005\%$ RO/°C
Temp. Effect on Out.	Within $\pm 0.005\%$ /°C
Electrical Characteristics	
Safe Excit. Voltage	20 V AC or DC
Recom. Excit. Voltage	1 to 12 V AC or DC
Input Resistance	350 $\Omega \pm 0.5\%$
Output Resistance	350 $\Omega \pm 0.5\%$
Cable	4-conductor (0.3 mm ²) chloroprene shielded cable, 7.6 mm dia. by 5 m long, terminated with an NDIS connector plug (Shield wire is not connected to the mainframe.)
Mechanical Properties	
Safe Overload Rating	400%
Natural Frequency	See table below.
Weight	See table below.
Protection Rating	IP 67 (Watertight type conforming to JIS C 0920)

Dimensions

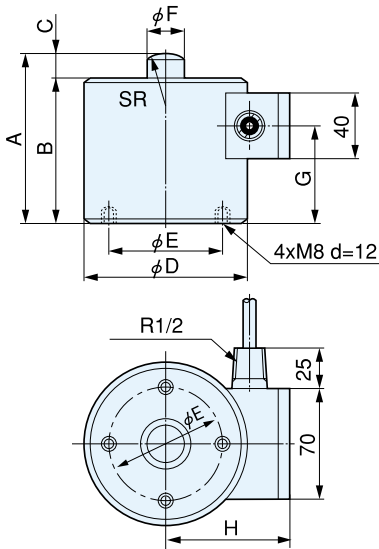

Model	Rated Capacity	Nat. Freq. (App.)	A	B	C	ϕD	ϕE	ϕF	G	H	R	Weight (App.)	Saddle
LC-500KJ	5 kN	5.2 kHz	103	90	13	100	80	24	60	77	50	3.6 kg	CA-1C
LC-1TJ	10 kN	6 kHz	103	90	13	100	80	24	60	77	70		CA-10C
LC-2TJ	20 kN	5.8 kHz										CA-50C	
LC-5TJ	50 kN	5.7 kHz										CA-50C	
LC-10TJ	100 kN	5.5 kHz	110	95	15	120	90	36	60	90	100	5.6 kg	CA-50C
LC-20TJ	200 kN	6 kHz	135	115	20	120	90	46	80	90	130	6.6 kg	

Dimensions with Accessories Mounted

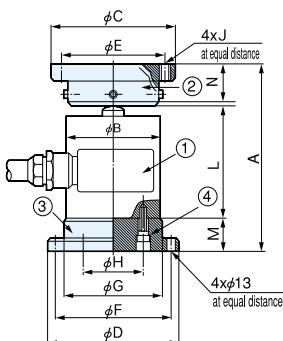

• In Combination with Movable Saddle ER and Mount Base CF

Load Cell Proper ①	Movable Saddle ②	Mount Base ③	Hexagon Socket Head Cap Screw ④	A	ϕB	ϕC	ϕD	ϕE	ϕF	ϕG	ϕH	J	L	M	N
LC-500KJ	ER-1D	CF-80C	M8 L=25	182	100	138	148	118	124	100	80	M12	103	40	40
LC-1TJ	ER-5D	CF-80C	M8 L=25	192	100	148	148	128	124	100	80	M12	103	40	50
LC-2TJ				202	100	178	148	158	124	100	80	M12	103	40	60
LC-5TJ	ER-10D	CF-80C	M8 L=25	238	120	198	168	178	144	120	90	M12	110	50	80
LC-10TJ	ER-20D	CF-90C	M8 L=30	—	120	—	168	—	144	120	90	—	135	50	—
LC-20TJ	—	CF-90C	M8 L=35	—	—	—	168	—	—	—	—	—	—	—	—

Hexagon socket head cap screw is attached to the mount base for its connection to the load cell.

Washer-Type Compression Load Cells

For Press Forming

LCW-C-SA3

10 to 300 kN

Thin Structure

Abundant Rated Capacities



LCW-C-20KN25SA3

LCW-C-300KN60SA3

Load cells in the LCW-C-SA3 series feature an extremely simple structure facilitating handling and maintenance. They can be widely used for measurement of bolt tension, load applied to a press, etc.

Specifications

Performance	
Rated Capacity	See table below.
Nonlinearity	Within $\pm 1\%$ RO
Hysteresis	Within $\pm 1\%$ RO
Rated Output	Approx. 1 mV/V (2000 $\mu\text{m/m}$)
Environmental Capability	
Safe Temp. Range	-35 to 80°C
Comp. Temp. Range	-10 to 70°C
Temp. Effect on Zero Bal.	Within $\pm 0.01\%$ RO/ $^\circ\text{C}$
Temp. Effect on Out.	Within $\pm 0.01\%$ / $^\circ\text{C}$
Electrical Characteristics	
Safe Excit. Voltage	15 V AC or DC
Recom. Excit. Voltage	1 to 10 V AC or DC
Input Resistance	$350 \Omega \pm 1\%$
Output Resistance	$350 \Omega \pm 1\%$
Cable	4-conductor (0.3 mm ²) chloroprene shielded cable, 7.6 mm dia. by 5 m long, bared at the tip (Shield wire is not connected to the mainframe.)
Mechanical Properties	
Safe Overload Rating	150%
Weight	See table below.
Protection Rating	IP 64 (Sprashproof type conforming to JIS C 0920)

Dimensions

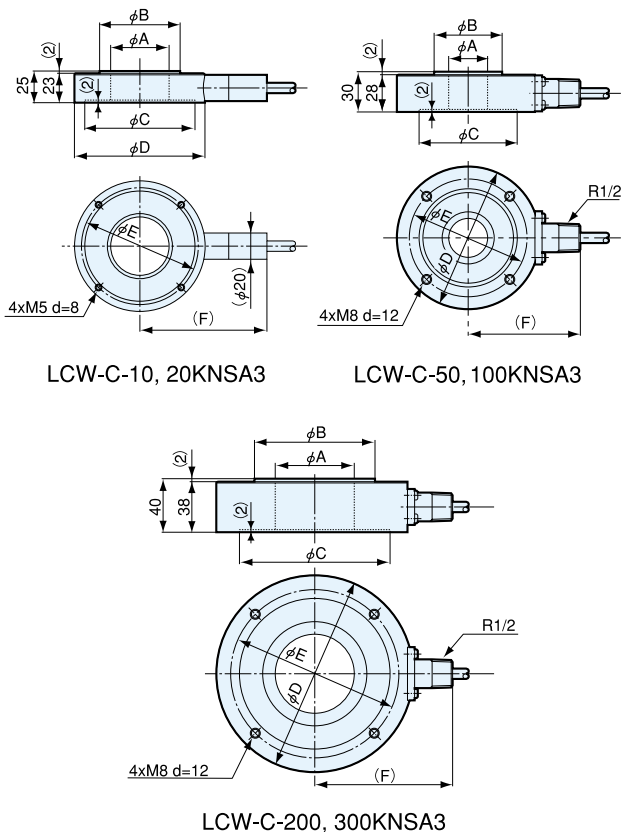

LCW-C-10, 20KNSA3

LCW-C-50, 100KNSA3

LCW-C-200, 300KNSA3

Model	Rated Capacity	ϕA	ϕB	ϕC	ϕD	ϕE	F)	Wt. (App.)
LCW-C-10KN25SA3	10 kN	25	42	64	80	70	87	0.6 kg
LCW-C-10KN35SA3		35	52	74	90	80	92	0.7 kg
LCW-C-10KN45SA3		45	62	84	100	90	97	0.8 kg
LCW-C-10KN55SA3		55	72	94	110	100	102	0.9 kg
LCW-C-10KN65SA3		65	82	104	120	110	107	1.0 kg
LCW-C-20KN25SA3	20 kN	25	42	64	80	70	87	0.6 kg
LCW-C-20KN35SA3		35	52	74	90	80	92	0.7 kg
LCW-C-20KN45SA3		45	62	84	100	90	97	0.8 kg
LCW-C-20KN55SA3		55	72	94	110	100	102	0.9 kg
LCW-C-20KN65SA3		65	82	104	120	110	107	1.0 kg
LCW-C-50KN30SA3	50 kN	30	52	74	108	90	85	1.7 kg
LCW-C-50KN40SA3		40	62	84	118	100	90	1.9 kg
LCW-C-50KN50SA3		50	72	94	128	110	95	2.1 kg
LCW-C-50KN60SA3		60	82	104	138	120	100	2.3 kg
LCW-C-50KN70SA3		70	92	114	148	130	105	2.5 kg
LCW-C-50KN80SA3	80	102	124	158	140	110	2.7 kg	
LCW-C-100KN30SA3	100 kN	30	52	74	108	90	85	1.7 kg
LCW-C-100KN40SA3		40	62	84	118	100	90	1.9 kg
LCW-C-100KN50SA3		50	72	94	128	110	95	2.1 kg
LCW-C-100KN60SA3		60	82	104	138	120	100	2.3 kg
LCW-C-100KN70SA3		70	92	114	148	130	105	2.5 kg
LCW-C-100KN80SA3	80	102	124	158	140	110	2.7 kg	
LCW-C-200KN60SA3	200 kN	60	92	114	148	130	105	3.7 kg
LCW-C-200KN70SA3		70	102	124	158	140	110	4.1 kg
LCW-C-200KN80SA3		80	112	134	168	150	115	4.4 kg
LCW-C-200KN90SA3		90	122	144	178	160	121	4.8 kg
LCW-C-200KN100SA3		100	132	154	188	170	126	5.1 kg
LCW-C-300KN60SA3	300 kN	60	92	114	148	130	105	3.7 kg
LCW-C-300KN70SA3		70	102	124	158	140	110	4.1 kg
LCW-C-300KN80SA3		80	112	134	168	150	115	4.4 kg
LCW-C-300KN90SA3		90	122	144	178	160	121	4.8 kg
LCW-C-300KN100SA3		100	132	154	188	170	126	5.1 kg

Washer-Type Compression Load Cells

For Rolling/Drepressing Pressure Measurement under Harsh Environment

LCW-D-S/E-S

1 to 5 MN

Hermetically Sealed Structure with Inert Gas Filled in

Heat- and Oil-Resistant Cable

High Stability



Hermetically-sealed structure with inert gas filled in ensures highly reliable, stable operation for a long period of time under harsh conditions. The flat washer-type structure requires only fabrication of screw nuts for installation to existing rolling mills.

Load cells which meet individual rolling mills can also be manufactured. Inquiries are welcome.

Specifications

Performance	
Rated Capacity	See table below.
Nonlinearity	Within $\pm 1\%$ RO
Hysteresis	Within $\pm 1\%$ RO
Repeatability	0.3% RO or less
Rated Output	1 mV/V (2000 $\mu\text{m/m}$) or more
Environmental Capability	
Safe Temp. Range	-20 to 100°C
Comp. Temp. Range	-10 to 80°C
Temp. Effect on Zero Bal.	Within $\pm 0.01\%$ RO/°C
Temp. Effect on Out.	Within $\pm 0.01\%$ /°C
Electrical Characteristics	
Safe Excit. Voltage	15 V AC or DC
Recom. Excit. Voltage	1 to 10 V AC or DC
Input Resistance	350 $\Omega \pm 1\%$
Output Resistance	350 $\Omega \pm 1\%$
Cable	4-conductor (0.75 mm ²) fluonlex shielded cable, 8 mm dia. by 15 m long, bared at the tip (Shield wire is not connected to the mainframe.)

Dimensions

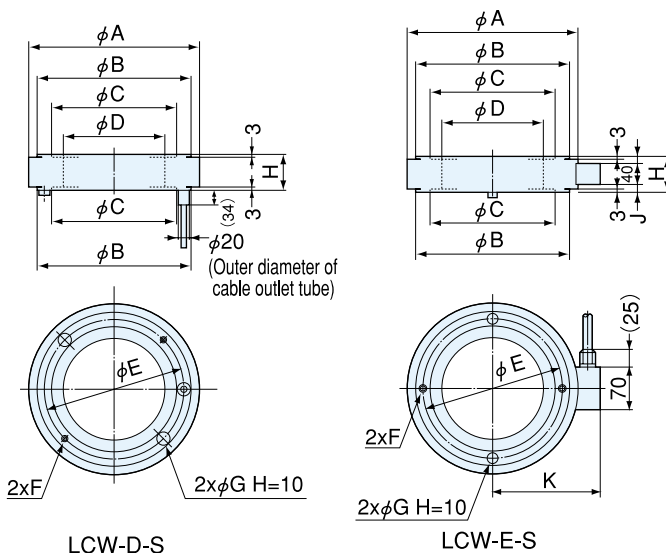

Mechanical Properties	
Safe Overload Rating	150%
Natural Frequency	See table below.
Weight	See table below.
Protection Rating	IP 64 (Sprashproof type conforming to JIS C 0920)

Model	Rated Capacity	Natural Freq. (App.)	ϕA	ϕB	ϕC	ϕD	ϕE	F	ϕG	H	J	K	Weight (App.)
LCW-D-1MNS	1 MN	16 kHz	241	202	178	140	190	M8 d=8	8	64	—	—	7 kg
LCW-D-2MNS	2 MN	14 kHz	355	307	277	230	292	M10 d=10	12	70	—	—	15 kg
LCW-D-3MNS	3 MN	15 kHz	355	314	270	230	292	M10 d=12	20	70	—	—	17 kg
LCW-D-5MNS	5 MN	16 kHz	355	312	252	210	282	M10 d=12	20	70	—	—	20 kg
LCW-E-1MNS	1 MN	16 kHz	241	202	178	140	190	M8 d=8	8	64	16	155	7 kg
LCW-E-2MNS	2 MN	14 kHz	355	307	277	230	292	M10 d=10	12	70	18	213	15 kg
LCW-E-3MNS	3 MN	15 kHz	355	314	270	230	292	M10 d=12	20	70	18	213	17 kg
LCW-E-5MNS	5 MN	16 kHz	355	312	252	210	282	M10 d=12	20	70	18	213	20 kg

Stainless Steel Load Cells

LCTS-B

5 to 100 kN

Stainless Steel

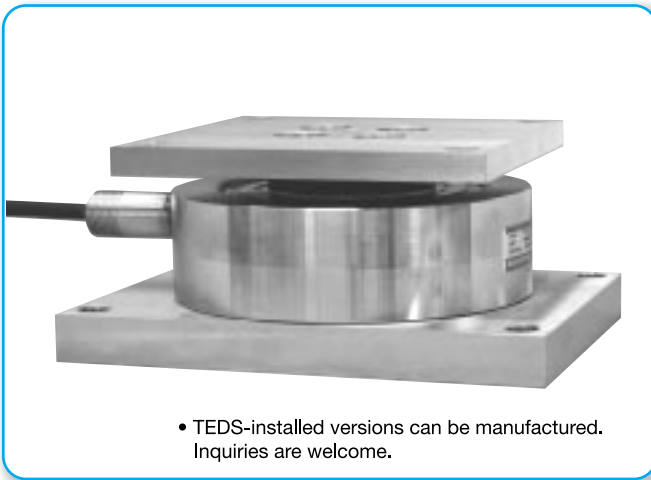

Features

- Stainless steel structure enables use under conditions where the load cell is exposed to moisture and corrosive gases.
- "Thin" and "top and bottom plates integrated" design facilitates installation to hopper brackets or tank's feet.
- Hermetically-sealed structure (protection rating IP67)
- Built-in steady brace mechanism makes LCTS-B suitable for weighing stirring tanks or tanks with feet, while simplifying peripheral facilities by eliminating check rod, etc.
- Since the load cell can be fixed with bolts, dropping or floating of the load cell can be prevented.

Dimensions

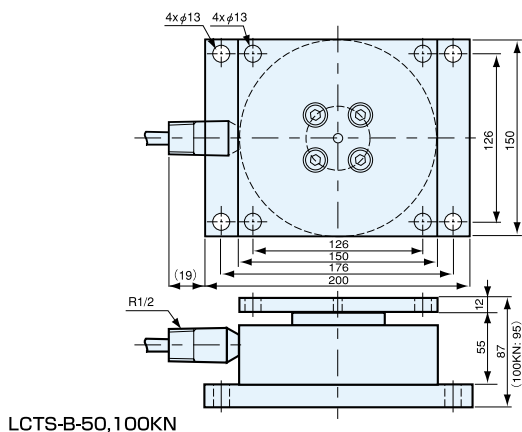
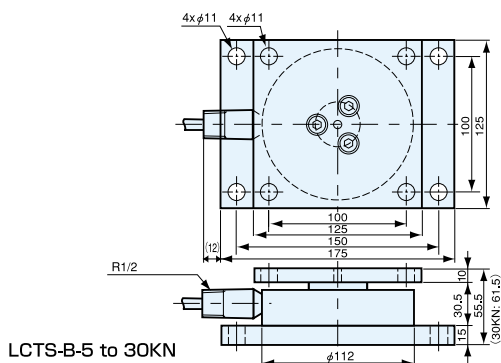

Developed for weighing hoppers and tanks, LCTS-B series is stainless steel compression load cells with built-in steady brace mechanism.

Specifications

Performance	
Rated Capacity	See table below.
Nonlinearity	Within $\pm 0.03\%$ RO
Hysteresis	Within $\pm 0.03\%$ RO
Repeatability	0.02% RO or less
Rated Output	2 mV/V (4000 $\mu\text{m/m}$) $\pm 0.1\%$
Environmental Capability	
Safe Temp. Range	-20 to 70°C
Comp. Temp. Range	-10 to 60°C
Temp. Effect on Zero Bal.	Within $\pm 0.003\%$ RO/°C
Temp. Effect on Out.	Within $\pm 0.003\%$ /°C
Electrical Characteristics	
Safe Excit. Voltage	20 V AC or DC
Recom. Excit. Voltage	1 to 10 V AC or DC
Input Resistance	700 $\Omega \pm 0.7\%$
Output Resistance	700 $\Omega \pm 0.7\%$
Cable	4-conductor (0.3 mm ²) chloroprene shielded cable, 7.6mm dia. by 5 m long (50, 100KN: 10 m long), bared at the tip (Shield wire is not connected to the mainframe.)

Mechanical Properties	
Safe Overload Rating	150%
Critical Lateral Load*	10 kN (50, 100 kN: 30 kN)
Weight	See table below.
Enclosure	Stainless steel alloy
Protection Rating	IP 67 (Watertight type conforming to JIS C 0920)

*Maximum load which does not cause any mechanical damage.

Model	Rated Capacity	Weight (App.)
LCTS-B-5KN	5 kN	5 kg
LCTS-B-10KN	10 kN	
LCTS-B-20KN	20 kN	
LCTS-B-30KN	30 kN	6 kg
LCTS-B-50KN	50 kN	11 kg
LCTS-B-100KN	100 kN	13 kg

To Ensure Safe Usage

■ Accessories to Load Cell

Do not disassemble or remodel accessories such as top plate and mounting plate designed for installation of LCTS-B series load cells.

■ Installation of Floating Prevention Stopper

Install the hazard prevention stopper when using in an environment where the load cell may be damaged or the hopper or tank may overturn due to lateral load or lateral displacement caused by thermal expansion of structure or vibration of stirrer.

Precautions

1. LCTS-B cannot be used for any onboard measurement.
2. LCTS-B cannot be used in an environment where it is frequently exposed to lateral load.
3. LCTS-B cannot be installed to any inclined or vertical surface.

Installation Examples

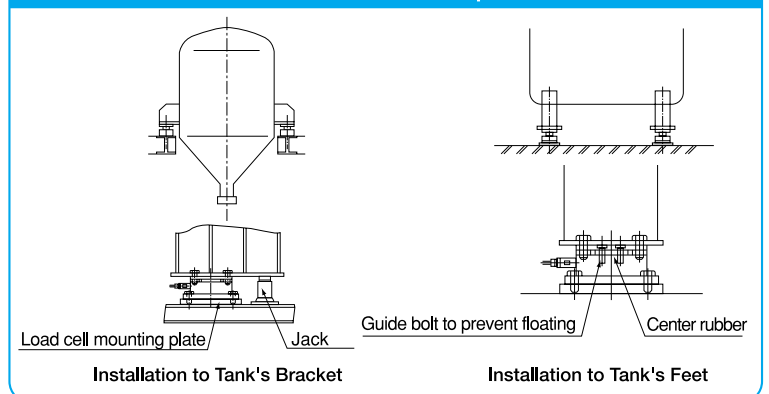

Thin Load Cells "Multiforce Sensor"

LCTA-A

500 N to 3 kN

Thin



- TEDS-installed versions can be manufactured. Inquiries are welcome.

Features

- **Advanced thin design** – When compared with conventional load cells, the height is 1/2 to 1/3. Space saving expands the application range.
- **Usable with top and bottom fixed** – Optional dedicated rubber attachment enables fixing the top and bottom with bolts, thereby making it possible to design the system with no tension rod or stay rod used.
- **Strong against lateral load** – Safety factor is 3 to 5 times higher than conventionals. Endures lateral loads up to 20% of the rated capacity.
- **Excellent impact/vibration resistance** – Rubber attachment attenuates impact energy and lessens the effects of thermal expansion of system and moment of fixed section.
- **Easy installation** – Rubber attachment facilitates installation with less care about parallelism.
- **Wide variation in accuracy and reliability** – Varieties of accuracies and outputs are available, enabling configuration of the most suitable system for each individual application.
- **Compatibility with peripheral equipment** – Since wirings are the same as conventional load cells, peripheral instruments such as amplifiers can easily be connected.

Dimensions

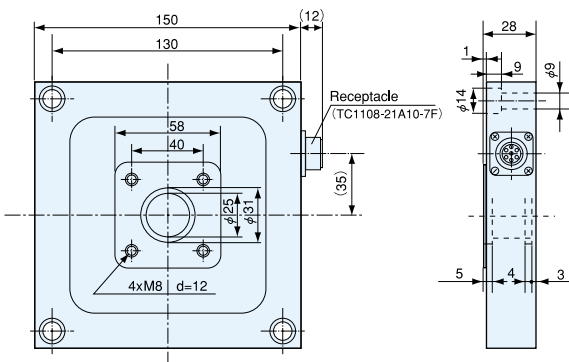

High technologies cultivated in weight control of large-scale airplanes and original ideas are incorporated into the revolutionary thin design of LCTA-A series load cells. Besides accuracy, the integrated flat design and rubber attachment enable use with the top and bottom fixed and provide excellent buffer function and ease of use.

Specifications

Performance

Rated Capacity	Model	Rated Capacity
	LCTA-A-500N	500 N
	LCTA-A-800N	800 N
	LCTA-A-1KN	1 kN
	LCTA-A-2KN	2 kN
	LCTA-A-3KN	3 kN

Nonlinearity	Within $\pm 0.05\%$ RO
Hysteresis	Within $\pm 0.05\%$ RO
Repeatability	0.03% RO or less
Rated Output	2 mV/V (4000 $\mu\text{m/m}$) $\pm 0.2\%$

Environmental Capability

Safe Temp. Range	-20 to 70°C
Comp. Temp. Range	-10 to 60°C
Temp. Effect on Zero Bal.	Within $\pm 0.01\%$ RO/ $^\circ\text{C}$
Temp. Effect on Out.	Within $\pm 0.01\%$ / $^\circ\text{C}$

Electrical Characteristics

Safe Excit. Voltage	20 V DC
Recom. Excit. Voltage	1 to 10 V DC
Input Resistance	350 $\Omega \pm 1.5\%$
Output Resistance	350 $\Omega \pm 1.5\%$
Cable	4-conductor (0.5 mm ²) vinyl sheath shielded cable, 8 mm dia. by 5 m long, bared at the tip (Shield wire is not connected to the mainframe.)

Mechanical Properties

Safe Overload Rating	150%
Critical Lateral Load	20% (Maximum load which does not cause any mechanical damage)
Weight	Approx. 1.1 kg
Enclosure	Aluminum alloy

Precautions

1. LCTA-A cannot be used for any onboard measurement.
2. LCTA-A cannot be used in an environment where it is frequently exposed to lateral load.
3. LCTA-A cannot be installed to any inclined or vertical surface.

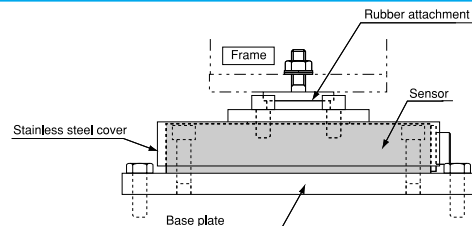

Applicable Accessories

Model	Stainless Steel Cover	Rubber Attachment	Base Plate
LCTA-A-500N	COV03-300K	RA02-100K	BP03-300K
LCTA-A-800N			
LCTA-A-1KN			
LCTA-A-2KN		RA02-300K	
LCTA-A-3KN			

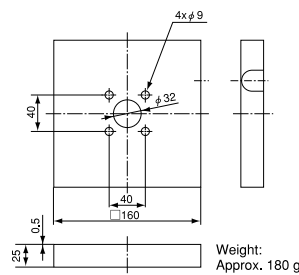

Stainless Steel Cover

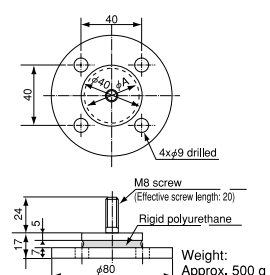

Rubber Attachment

For base plate, refer to page 40.

Model	A
RA02-100K	30
RA02-300K	36

Thin Load Cells "Multiforce Sensor"

LCTB-A

5 to 50 kN

Thin



Features

- Advanced thin design – When compared with conventional load cells, the height is 1/2 to 1/3. Space saving expands the application range.
- Usable with top and bottom fixed – Optional dedicated rubber attachment enables fixing the top and bottom with bolts, thereby making it possible to design the system with no tension rod or stay rod used.
- Strong against lateral load – Safety factor is 3 to 5 times higher than conventionals. Endures lateral loads up to 50% of the rated capacity.
- Excellent impact/vibration resistance – Rubber attachment attenuates impact energy and lessens the effects of thermal expansion of system and moment of fixed section.
- Easy installation – Rubber attachment facilitates installation with less care about parallelism.
- Wide variation in accuracy and reliability – Varieties of accuracies and outputs are available, enabling configuration of the most suitable system for each individual application.
- Compatibility with peripheral equipment – Since wirings are the same as conventional load cells, peripheral instruments such as amplifiers can easily be connected.

Dimensions

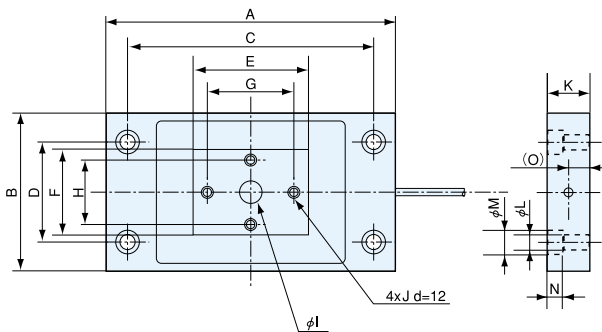

Specifications

Performance	
Rated Capacity	See table below.
Nonlinearity	Within $\pm 0.03\%$ RO
Hysteresis	Within $\pm 0.03\%$ RO
Repeatability	0.02% RO or less
Rated Output	1.5 mV/V (3000 $\mu\text{m/m}$) $\pm 0.2\%$
Environmental Capability	
Safe Temp. Range	-20 to 70°C
Comp. Temp. Range	-10 to 60°C
Temp. Effect on Zero Bal.	Within $\pm 0.005\%$ RO/°C
Temp. Effect on Out.	Within $\pm 0.005\%$ /°C
Electrical Characteristics	
Safe Excit. Voltage	20 V DC
Recom. Excit. Voltage	1 to 10 V DC
Input Resistance	350 $\Omega \pm 1.5\%$
Output Resistance	350 $\Omega \pm 1.5\%$
Cable	4-conductor (0.5 mm ²) chloroprene shielded cable, 6 mm dia. by 5 m long, bared at the tip (Shield wire is not connected to the mainframe.)
Mechanical Properties	
Safe Overload Rating	150%
Critical Lateral Load	50% (Maximum load which does not cause any mechanical damage)
Weight	See table below.
Enclosure	Aluminum alloy

Precautions

1. LCTB-A cannot be used for any onboard measurement.
2. LCTB-A cannot be used in an environment where it is frequently exposed to lateral load.
3. LCTB-A cannot be installed to any inclined or vertical surface.

Applicable Accessories

Model	Stainless Steel Cover	Rubber Attachment	Base Plate
LCTB-A-5KN			
LCTB-A-10KN	COV01-2T	RA01-2T	BP01-2T
LCTB-A-20KN			
LCTB-A-30KN	COV01-5T	RA01-5T	BP01-5T
LCTB-A-50KN			

Stainless Steel Cover

Model	A	B	C	D	E	φF	G	Weight (App.)
COV01-2T	206	116	25	5.5	45	18	M8	400 g
COV01-5T	270	160	35	9.5	60	22	M10	900 g

For rubber attachment and base plate, refer to page 40.

Model	Rated Capacity	A	B	C	D	E	F	G	H	φI	J	K	φL	φM	N	O	Weight (App.)
LCTB-A-5KN	5 kN	200	110	170	70	80	60	60	45	16	M8	29	11	17	11	15	1.8 kg
LCTB-A-10KN	10 kN											35				16.5	2.3 kg
LCTB-A-20KN	20 kN	260	150	220	90	90	80	60	60	20	M10	39	13	19	13	19	4.3 kg
LCTB-A-30KN	30 kN											49				24	5.3 kg
LCTB-A-50KN	50 kN																

Thin Load Cells "Multiforce Sensor"

LCTE-A

10 to 100 kN

Thin



• TEDS-installed versions can be manufactured. Inquiries are welcome.

Features

- Advanced thin design – When compared with conventional load cells, the height is 1/2 to 1/3. Space saving expands the application range.
- Usable with top and bottom fixed – Optional dedicated rubber attachment enables fixing the top and bottom with bolts, thereby making it possible to design the system with no tension rod or stay rod used.
- Strong against lateral load – Safety factor is 3 to 5 times higher than conventionals. Endures lateral loads up to 50% of the rated capacity.
- Excellent impact/vibration resistance – Rubber attachment attenuates impact energy and lessens the effects of thermal expansion of system and moment of fixed section.
- Easy installation – Rubber attachment facilitates installation with less care about parallelism.
- Wide variation in accuracy and reliability – Varieties of accuracies and outputs are available, enabling configuration of the most suitable system for each individual application.
- Compatibility with peripheral equipment – Since wirings are the same as conventional load cells, peripheral instruments such as amplifiers can easily be connected.

Dimensions

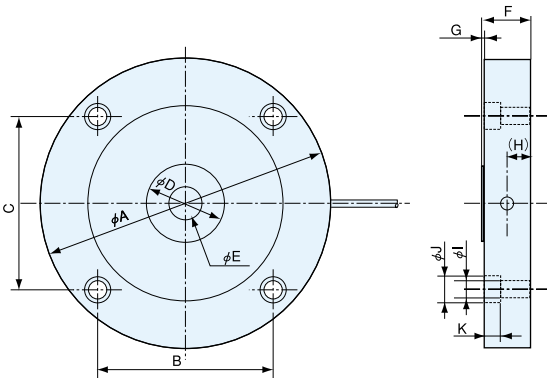

Specifications

Performance	
Rated Capacity	See table below.
Nonlinearity	Within $\pm 0.05\%$ RO (100KN: Within $\pm 0.1\%$ RO)
Hysteresis	Within $\pm 0.05\%$ RO (100KN: Within $\pm 0.1\%$ RO)
Repeatability	0.03% RO or less (100KN: 0.05% RO or less)
Rated Output	2 mV/V (4000 $\mu\text{m/m}$) $\pm 0.2\%$
Environmental Capability	
Safe Temp. Range	-20 to 70°C
Comp. Temp. Range	-10 to 60°C
Temp. Effect on Zero Bal.	Within $\pm 0.003\%$ RO/°C
Temp. Effect on Out.	Within $\pm 0.003\%$ /°C
Electrical Characteristics	
Safe Excit. Voltage	20 V DC
Recom. Excit. Voltage	1 to 10 V DC
Input Resistance	350 $\Omega \pm 1.5\%$
Output Resistance	350 $\Omega \pm 1.5\%$
Cable	4-conductor (0.3 mm ²) chloroprene shielded cable, 6 mm dia. by 5 m long (100KN: 10 m long), bared at the tip (Shield wire is not connected to the mainframe.)
Mechanical Properties	
Safe Overload Rating	150%
Critical Lateral Load	50% (Maximum load which does not cause any mechanical damage)
Weight	See table below.
Enclosure	Special steel

Precautions

1. LCCTE-A cannot be used for any onboard measurement.
2. LCCTE-A cannot be used in an environment where it is frequently exposed to lateral load.
3. LCCTE-A cannot be installed to any inclined or vertical surface.

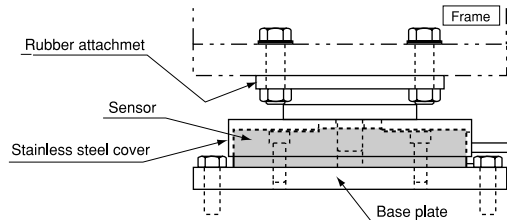

Applicable Accessories

Model	Stainless Steel Cover	Rubber Attachment	Base Plate	Base Plate (when stainless cover is used)
LCCTE-A-10KN	COV04-1T	RA01-2T	BP04-1T	BP04-1T01
LCCTE-A-20KN	COV04-3T	RA01-2T	BP04-2T	BP04-2T01
LCCTE-A-30KN			BP04-3T	BP04-3T01
LCCTE-A-50KN	COV04-10T	RA01-10T	BP04-5T	BP04-5T01
LCCTE-A-100KN			BP04-10T02	BP04-10T03

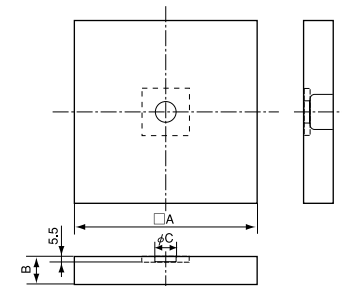

Stainless Steel Cover

Model	A	B	ϕC	Weight (App.)
COV04-1T	155	25	18	230 g
COV04-3T	185	30	22	380 g
COV04-10T	205	35	22	670 g

For rubber attachment and base plate, refer to page 41.

Model	Rated Capacity	ϕA	B	C	ϕD	ϕE	F	G	H	ϕI	ϕJ	K	Weight (App.)
LCCTE-A-10KN	10 kN	148	90	90	40	16	25	1	13	9	14	8.5	3.2 kg
LCCTE-A-20KN	20 kN	178	110	110	62		31		15	11	18	11	5.1 kg
LCCTE-A-30KN	30 kN					198	124	124	80	35	17	14	20
LCCTE-A-50KN	50 kN	37	3	7.2 kg									
LCCTE-A-100KN	100 kN												

Thin Load Cells "Multiforce Sensor" LCCTE-A

Thin Load Cells "Multiforce Sensor"

LCTD-A

100 to 300 kN

Thin

NEW



• TEDS-installed versions can be manufactured. Inquiries are welcome.

Features

- Advanced thin design – When compared with conventional load cells, the height is 1/2 to 1/3. Space saving expands the application range.
- Usable with top and bottom fixed – Optional dedicated rubber attachment enables fixing the top and bottom with bolts, thereby making it possible to design the system with no tension rod or stay rod used.
- Strong against lateral load – Safety factor is 3 to 5 times higher than conventionals. Endures lateral loads up to 50% of the rated capacity.
- Excellent impact/vibration resistance – Rubber attachment attenuates impact energy and lessens the effects of thermal expansion of system and moment of fixed section.
- Easy installation – Rubber attachment facilitates installation with less care about parallelism.
- Wide variation in accuracy and reliability – Varieties of accuracies and outputs are available, enabling configuration of the most suitable system for each individual application.
- Compatibility with peripheral equipment – Since wirings are the same as conventional load cells, peripheral instruments such as amplifiers can easily be connected.

Dimensions

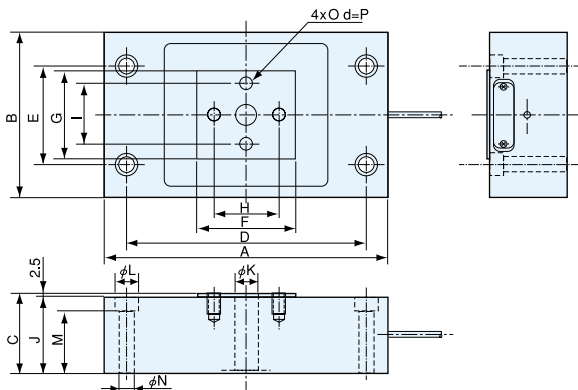

Specifications

Performance	
Rated Capacity	See table below.
Nonlinearity	Within $\pm 0.03\%$ RO
Hysteresis	Within $\pm 0.03\%$ RO
Repeatability	0.02% RO or less
Rated Output	2 mV/V (4000 $\mu\text{m/m}$) $\pm 0.2\%$
Environmental Capability	
Safe Temp. Range	-20 to 70°C
Comp. Temp. Range	-10 to 60°C
Temp. Effect on Zero Bal.	Within $\pm 0.003\%$ RO/°C
Temp. Effect on Out.	Within $\pm 0.003\%$ /°C
Electrical Characteristics	
Safe Excit. Voltage	20 V DC
Recom. Excit. Voltage	1 to 10 V DC
Input Resistance	350 $\Omega \pm 1.5\%$
Output Resistance	350 $\Omega \pm 1.5\%$
Cable	4-conductor (0.3 mm ²) chloroprene shielded cable, 7.6 mm dia. by 10 m long, bared at the tip (Shield wire is not connected to the mainframe.)
Mechanical Properties	
Safe Overload Rating	150%
Critical Lateral Load	50% (Maximum load which does not cause any mechanical damage)
Weight	See table below.
Enclosure	Special steel

Precautions

1. LCTD-A cannot be used for any onboard measurement.
2. LCTD-A cannot be used in an environment where it is frequently exposed to lateral load.
3. LCTD-A cannot be installed to any inclined or vertical surface.

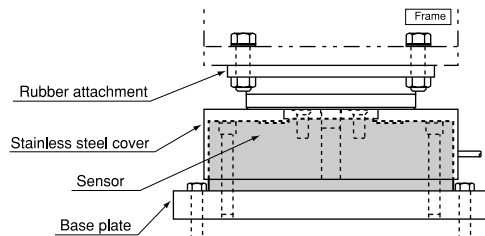

Applicable Accessories

Model	Stainless Steel Cover	Rubber Attachment	Base Plate
LCTD-A-100KN	COV02-10T	RA01-10T	BP02-10T
LCTD-A-200KN	COV02-20T	RA01-30T	BP02-20T
LCTD-A-300KN	COV02-30T		BP02-30T

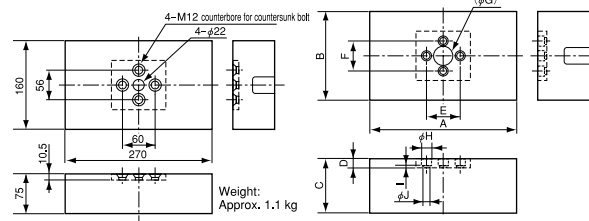

Model	Stainless Steel Cover (COV02-10T)										Weight (App.)
	A	B	C	D	E	F	(ϕ G)	ϕ H	I	ϕ J	
COV02-20T	270	160	100	10.5	60	56	35.5	18.5	3.5	13	1.6 kg
COV02-30T	316	216	100	19.5	70	80	38	26	9	18	2.6 kg

For rubber attachment and base plate, refer to page 41.

Model	Rated Capacity	A	B	C	D	E	F	G	H	I	J	ϕ K	ϕ L	M	ϕ N	O	P	Weight (App.)
LCTD-A-100KN	100 kN	260	150	74	220	90	90	80	60	56	71.5	20	20	58.5	14	M12	18.5	18 kg
LCTD-A-200KN	200 kN			93														23 kg
LCTD-A-300KN	300 kN	300	200	94	250	140	100	130	70	80	91.5	36	26	74	18	M16	28.5	33 kg

● Rubber Attachment

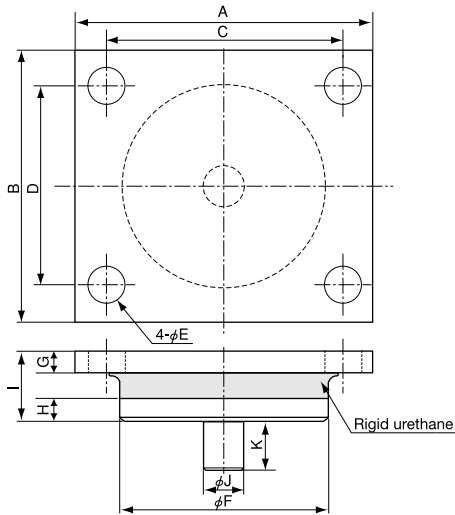

Model	A	B	C	D	φE	φF	G	H	I	φJ	K	Weight (App.)
RA01-2T	120	110	95	80	14	85	8.5	9.5	28	16	20	1.4 kg
RA01-5T	170	150	140	120		130		12.5	35			3.2 kg
RA01-10T	220	200	186	140	18	180	11.5	15.5	45			7.4 kg
RA01-30T	300	250	250	200	23	240	18.5	20.5	63	35	40	19.2 kg

● Base Plate

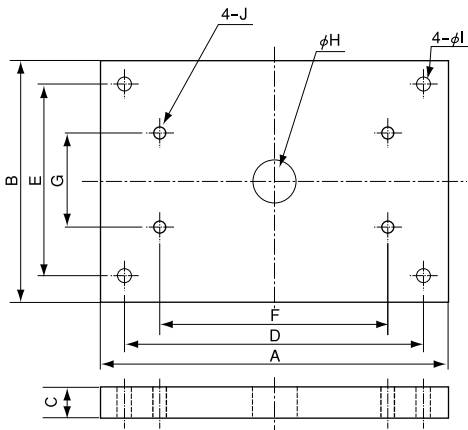

Applicable Load cell	Base Plate	A	B	C	D	E	F	G	φH	φI	J	
LCTA-A-500N LCTA-A-800N LCTA-A-1KN LCTA-A-2KN LCTA-A-3KN	BP03-300K	200	200	12	180	180	130	130	30	9	M8	
LCTB-A-5KN LCTB-A-10KN LCTB-A-20KN	BP01-2T	250	168	14	220	138	170	70	30	13	M10	
LCTB-A-30KN LCTB-A-50KN	BP01-5T	335	235	23	285	185	220	90	40		M12	
LCTE-A-10KN	BP04-1T BP04-1T01	170 200	170 200	14	140 175	140 175	90	90	30	11	M8	
LCTE-A-20KN	BP04-2T BP04-2T01	200 230	200 230		170 205	170 205						
LCTE-A-30KN	BP04-3T BP04-3T01	200 230	200 230	20	170 205	170 205	110	110	40	13	M10	
LCTE-A-50KN	BP04-5T BP04-5T01	220 260	220 260		180 230	180 230						
LCTE-A-100KN	BP04-10T02 BP04-10T03	220 260	220 260	30	180 230	180 230	124	124	40	18	M12	
LCTD-A-100KN	BP02-10T	335	235	30 38	285	185						220
LCTD-A-200KN	BP02-20T											
LCTD-A-300KN	BP02-30T	400	280	38	350	240	250	140	60	18	M16	

● 4-channel Junction Box JB4LC-US

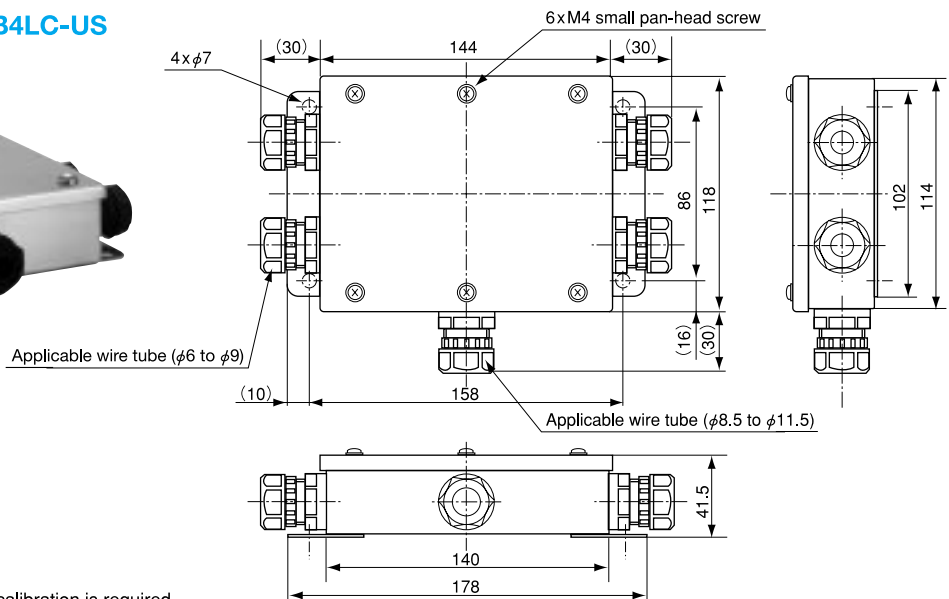

Note: Adjustment through actual load calibration is required.

High Temperature Compression Load Cells

FH: -10 to 150°C

LC-FH

500 N to 200 kN

Selectable from a Wide Range of Rated Capacities

High Reliability

Airtight Structure



- TEDS-installed versions can be manufactured. Inquiries are welcome.

LC-FH series enables continuous operation under temperatures as high as 150°C with no external cooling.

Specifications

Performance	
Rated Capacity	See table below.
Nonlinearity	Within $\pm 0.5\%$ RO
Hysteresis	Within $\pm 0.5\%$ RO
Repeatability	0.05% RO or less
Rated Output	1.5 mV/V (3000 $\mu\text{m/m}$) $\pm 0.2\%$
Environmental Capability	
Safe Temp. Range	FH -10 to 150°C
Comp. Temp. Range	FH -10 to 150°C
Temp. Effect on Zero Bal.	Within $\pm 0.005\%$ RO/°C
Temp. Effect on Out.	Within $\pm 0.01\%$ /°C
Electrical Characteristics	
Safe Excit. Voltage	20 V DC
Recom. Excit. Voltage	1 to 10 V DC
Input Resistance	350 $\Omega \pm 0.5\%$
Output Resistance	350 $\Omega \pm 0.5\%$
Cable	4-conductor (0.3 mm ²) fluoroplastic shielded cable, 5 mm dia. by 5 m long, terminated with NDIS connector plug (Shield wire is not connected to the mainframe.)
Mechanical Properties	
Safe Overload Rating	200%
Natural Frequency	See table below.
Weight	See table below.
Protection Rating	IP 52

Dimensions

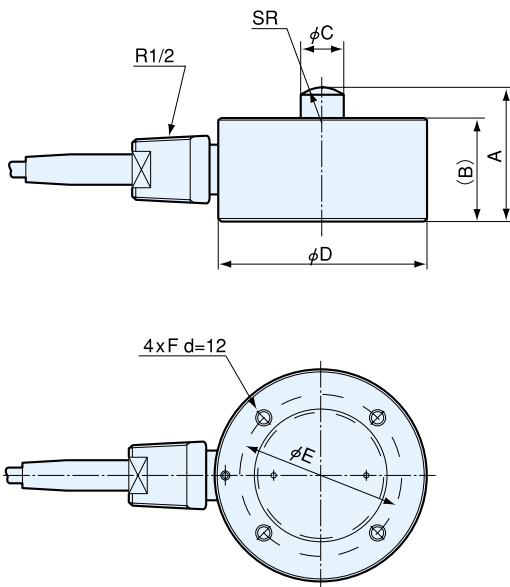

Model	Rated Capacity	Natural Frequency (App.)	A	B	φC	φD	φE	F	R	Weight (App.)
LC-50KFH	500 N	3.2 kHz	44	32	14	68	52	M5	12	1.5 kg
LC-100KFH	1 kN	5.1 kHz								
LC-200KFH	2 kN	7.2 Hz								
LC-500KFH	5 kN	11 kHz	44	32	14	68	52	M5	30	1.5 kg
LC-1TFH	10 kN	17 kHz	44	34	14	68	52	M5	30	1.5 kg
LC-2TFH	20 kN	21 kHz								
LC-5TFH	50 kN	16 kHz	60	45	18	96	80	M8	70	2.6 kg
LC-10TFH	100 kN	11 kHz	75	55	26	116	100	M8	100	4.2 kg
L -20TFH	200 kN	8.6 kHz	95	70	36	156	130	M8	100	8.5 kg

High/Low Temp. Tension Load Cells

FH: -10 to 150°C
FL: -196 to 30°C

LT-FH/FL

500 N to 200 kN

Wide Range of Rated Capacities

Mechanical Stopper which activates against 500% overload

High Reliability

Airtight Structure



• TEDS-installed versions can be manufactured. Inquiries are welcome.

LT-FH series enables continuous operation under temperatures as high as 150°C with no external cooling. LT-FL series enables operation under ultra-low temperature ranging from -196°C.

Specifications

Performance	
Rated Capacity	See table below.
Nonlinearity	Within $\pm 0.5\%$ RO
Hysteresis	Within $\pm 0.5\%$ RO
Repeatability	0.05% RO or less
Rated Output	1.5 mV/V (3000 $\mu\text{m/m}$) $\pm 0.2\%$
Environmental Capability	
Safe Temp. Range	FH -10 to 150°C
	FL -200 to 80°C
Comp. Temp. Range	FH -10 to 150°C
	FL -196 to 30°C
Temp. Effect on Zero Bal.	Within $\pm 0.005\%$ RO/°C
Temp. Effect on Out.	Within $\pm 0.01\%$ /°C
Electrical Characteristics	
Safe Excit. Voltage	20 V AC or DC
Recom. Excit. Voltage	1 to 10 V AC or DC
Input Resistance	350 $\Omega \pm 0.5\%$
Output Resistance	350 $\Omega \pm 0.5\%$
Cable	4-conductor (0,3 mm ²) fluoroplastic shielded cable, 5 mm dia. by 5 m long, terminated with NDIS connector plug (Shield wire is not connected to the mainframe.)

Mechanical Properties	
Safe Overload Rating	200%
Critical Overload Rating	500%
Natural Frequency	See table below.
Weight	See table below.
Protection Rating	IP 52

- For special accessories to tension load cells such as rotating attachments, ball joints, hooks and shackles, refer to pages 79 and 80.
- Use these special accessories pre-attached to load cells at our factory.

Dimensions

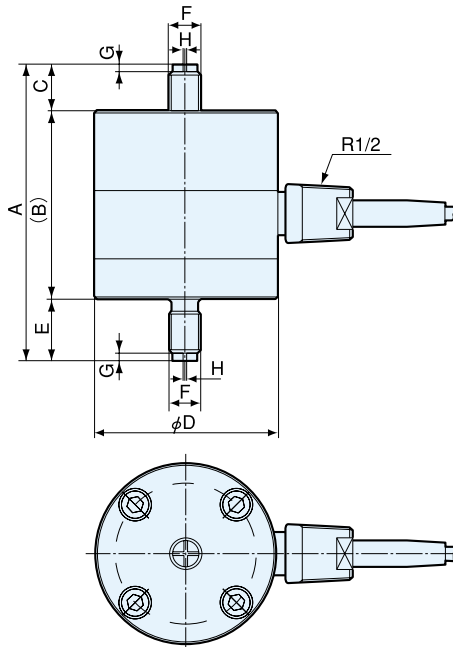

High Temp.	Low Temp.	Rated Capacity	Natural Frequency (App.)	A	B	C	ϕD	E	F	G	H	Weight (App)
LT-50KFH	LT-50KFL	500 N	1.5 kHz	111	71	17	68	23	M12 P=1.75	3	1.6	2.3 kg
LT-100KFH	LT-100KFL	1 kN	2.6 kHz									
LT-200KFH	LT-200KFL	2 kN	4.1 Hz									
LT-500KFH	LT-500KFL	5 kN	5.0 kHz	129	82	20	68	27	M14 P=2	5	3	2.6 kg
LT-1TFH	LT-1TFL	10 kN	5.2 kHz	143	84	26	68	33	M18 P=1.5	5	3	2.7 kg
LT-2TFH	LT-2TFL	20 kN	5.8 kHz	168	89	35	68	44	M24 P=2	5	3	2.9 kg
LT-5TFH	LT-5TFL	50 kN	4.5 kHz	236	126	55	96	55	M39 P=3	6	6	7.0 kg
LT-10TFH	LT-10TFL	100 kN	3.3 kHz	317	167	75	135	75	M56 P=3	6	6	19 kg
LT-20TFH	LT-20TFL	200 kN	2.4 kHz	421	221	100	185	100	M76 P=4	8	8	45 kg

High-Accuracy Tension Load Cells

Small-Sized, High Accuracy

LTZ-A

500 N to 50 kN

Compact and Lightweight

Nonlinearity 1/3333

Large Output

Usable also for Compression Load Measurement

• Extra calibration and patch are required.

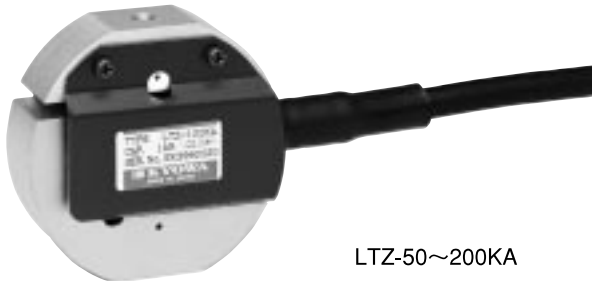

LTZ-50~200KA



LTZ-500KA~2TA

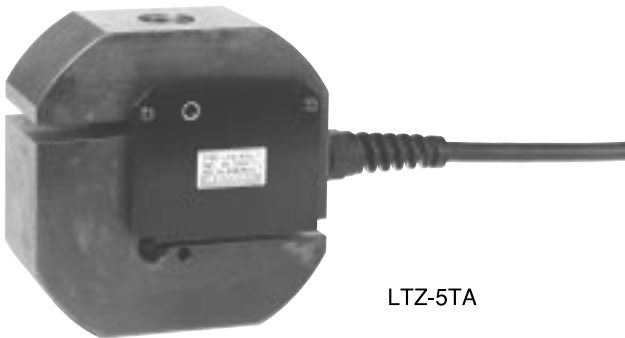

LTZ-5TA

• TEDS-installed versions can be manufactured. Inquiries are welcome.

The LTZ-A series load cells adopt a Roberval's mechanism to ensure 1/3333 accuracy and easy handling and maintenance. Since they can be installed with less burden to existing facilities, they are used as compact, lightweight load cells with excellent cost performance for weighing or testing systems in various fields.

Specifications

Performance	
Rated Capacity	See table below.
Nonlinearity	Within $\pm 0.03\%$ RO (500KA to 5TA: Within $\pm 0.05\%$ RO)
Hysteresis	Within $\pm 0.03\%$ RO (500KA to 5TA: Within $\pm 0.05\%$ RO)
Repeatability	0.03% RO or less
Rated Output	3 mV/V (6000 $\mu\text{m/m}$) $\pm 0.2\%$
Environmental Capability	
Safe Temp. Range	-20 to 80°C
Comp. Temp. Range	-10 to 70°C
Temp. Effect on Zero Bal.	Within $\pm 0.005\%$ RO/°C
Temp. Effect on Out.	Within $\pm 0.005\%$ /°C
Electrical Characteristics	
Safe Excit. Voltage	20 V AC or DC
Recom. Excit. Voltage	1 to 10 V AC or DC
Input Resistance	350 $\Omega \pm 0.5\%$
Output Resistance	350 $\Omega \pm 0.5\%$
Cable	4-conductor (0.5 mm ²) chloroprene shielded cable, 8.5 mm dia. by 3 m long, with press-fit terminal for 4 mm (Shield wire is not connected to the mainframe.)
Mechanical Properties	
Safe Overload Rating	150%
Enclosure	Aluminum alloy (mainframe of 50 to 200KA)
Natural Frequency	See table below.
Weight	See table below.
Protection Rating	IP 64 (Sprashproof type conforming to JIS C 0920)

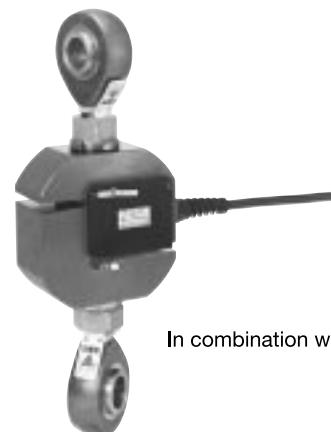

In combination with Ball Joint

Model	Rated Capacity	Natural Frequency (App.)	Weight (App.)
LTZ-50KA	500 N	1.25 kHz	300g
LTZ-100KA	1 kN	1.75 kHz	
LTZ-200KA	2 kN	2 kHz	
LTZ-500KA	5 kN	2.5 kHz	700g
LTZ-1TA	10 kN	2.8 kHz	
LTZ-2TA	20 kN	2.6 kHz	1.5 kg
LTZ-5TA	50 kN	4.3 kHz	4.4 kg

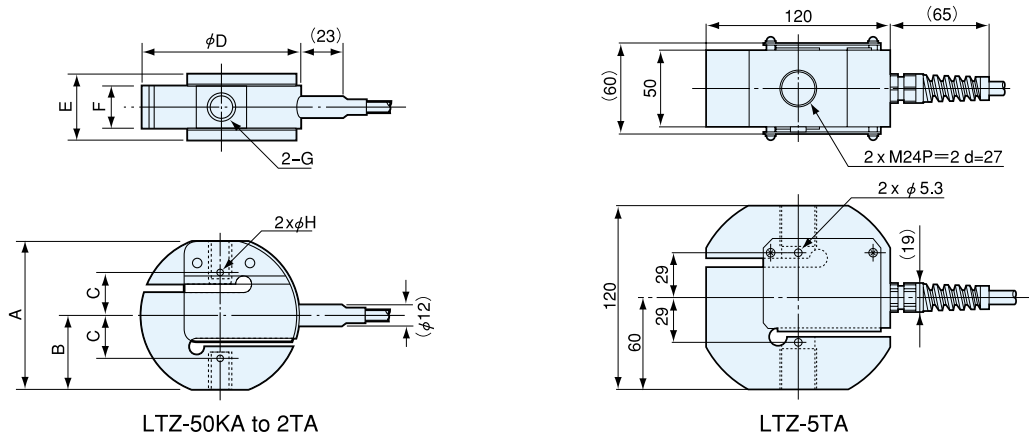

Model	A	B	C	ϕD	E	F	G	ϕH
LTZ-50KA	64	32	19	68	32	22	M6 P=1 d=14	1.6
LTZ-100KA								
LTZ-200KA								
LTZ-500KA	74	37	21	78	32	22	M12 P=1.75 d=18	3.5
LTZ-1TA								
LTZ-2TA	94	47	23	98	40	30	M18 P=1.5 d=25	3.5
LTZ-5TA	See the dimensional drawing above.							

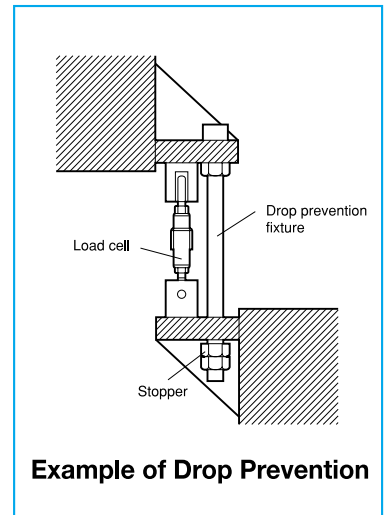
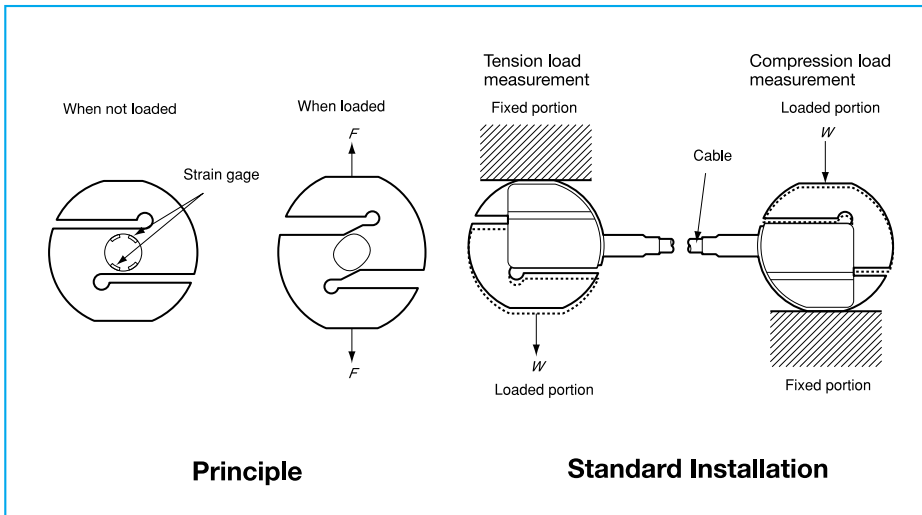

Dimensions in Combination with Special Accessories

● **Contact us for using the tension load cell in combination with special accessories.**

Note: Special accessories to tension load cells should be pre-attached to load cells at our factory.

● **In Combination with Patch CWM**

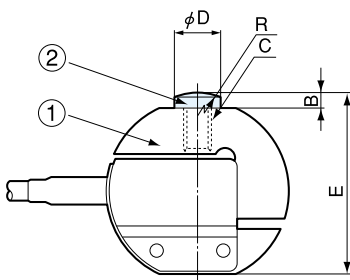

① Load Cell	② Patch	B	C	ϕD	E	R
LTZ-50KA	CWM-6	4	M6 P=1	10	68	SR30
LTZ-100KA						
LTZ-200KA						
LTZ-500KA	CWM-12	7	M12 P=1.75	19	81	SR30
LTZ-1TA						
LTZ-2TA	CWM-18	10	M18 P=1.5	26	104	SR70
LTZ-5TA	CWM-24	17	M24 P=2	36	137	

Dimensions in Combination with Special Accessories

● Contact us for using the tension load cell in combination with special accessories.

Note: Special accessories to tension load cells should be pre-attached to load cells at our factory.

● In Combination with Patch CWM, Mount Base CF and Saddle CA

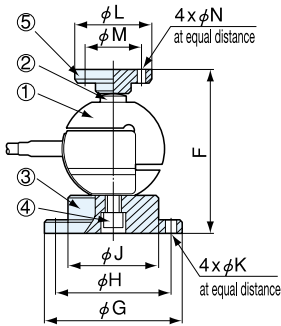

① Load Cell	② Patch	③ Mount Base	④ Hexagon Socket Head Bolt*	⑤ Saddle	F	φG	φH	φJ	φK	φL	φM	φN
LTZ-50KA	CWM-6	CF-6	M6 P=1 L=20	CA-2B	107	88	72	56	7	53	38	7
LTZ-100KA												
LTZ-200KA												
LTZ-500KA	CWM-12	CF-12	M12 P=1.75 L=30	CA-2B	130	105	87	70	9	53	38	7
LTZ-1TA												
LTZ-2TA	CWM-18	CF-18	M18 P=1.5 L=30	CA-2B	153	105	87	70	9	53	38	7
LTZ-5TA	CWM-24	CF-24	M24 P=2 L=40	CA-10B	201	148	124	100	13	98	80	11

*Hexagon socket head bolt is attached to the mount base for its connection to the load cell.

● In Combination with Patch CWM, Mount Base CF and Movable Saddle ER

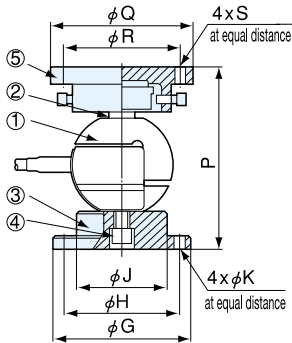

① Load Cell	② Patch	③ Mount Base	④ Hexagon Socket Head Bolt*	⑤ Movable Saddle	φG	φH	φJ	φK	P	φQ	φR	S
LTZ-50KA	CWM-6	CF-6	M6 P=1 L=20	ER-2B	88	72	56	7	122	108	90	M8
LTZ-100KA												
LTZ-200KA												
LTZ-500KA	CWM-12	CF-12	M12 P=1.75 L=30	ER-2B	105	87	70	9	145	108	90	M8
LTZ-1TA												
LTZ-2TA	CWM-18	CF-18	M18 P=1.5 L=30	ER-2B	105	87	70	9	168	108	90	M8
LTZ-5TA	CWM-24	CF-24	M24 P=2 L=40	ER-5B	148	124	100	13	226	148	128	M12

*Hexagon socket head bolt is attached to the mount base for its connection to the load cell.

● In Combination with Ball Joint TU

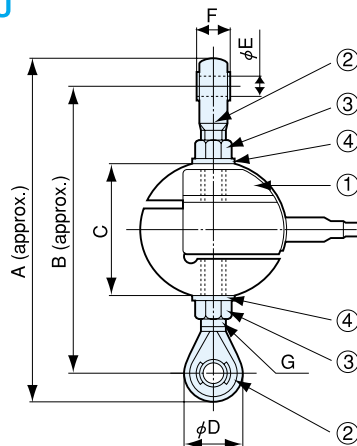

① Load Cell	② Ball Joint	③ Hexagon Nut	④ Spring Washer	A	B	C	φD	φE	F	G	Static Breaking Load (Approx.)
LTZ-50KA	TU-6C	M6 P=1	#2 6S	128	110	64	18	6	9	M6 P=1	1.4 kN
LTZ-100KA											2.9 kN
LTZ-200KA											5.8 kN
LTZ-500KA	TU-12C	M12 P=1.75	#2 12S	196	166	74	30	12	16	M12 P=1.75	14.7 kN
LTZ-1TA											29.4 kN
LTZ-2TA	TU-18C	M18 P=1.5	#2 18S	232	190	94	42	18	23	M18 P=1.5	58.8 kN
LTZ-5TA	TU-24C	M24 P=2	#3 24S	346	276	120	70	25	37	M24 P=2	147 kN

Dimensions A and B are approximate, since the ball joint is screw-in type.

Tension/Compression Load Cells

For Both Tension & Compression Loads

LU-E **Made to order**

500 N to 200 kN

Hermetically-Sealed Structure with Inert Gas Filled in

For Both Tension & Compression Loads



• TEDS-installed versions can be manufactured. Inquiries are welcome.

The detection portion is hermetically sealed with inert gas filled in to prevent aging deterioration and to ensure reliability and stability for a long period of time.

Specifications

Performance	
Rated Capacity	See table below.
Nonlinearity	Within $\pm 0.2\%$ RO
Hysteresis	Within $\pm 0.1\%$ RO
Repeatability	0.1% RO or less
Rated Output	2 mV/V (4000 $\mu\text{m/m}$) $\pm 0.2\%$
Environmental Capability	
Safe Temp. Range	-30 to 85°C
Comp. Temp. Range	-10 to 70°C
Temp. Effect on Zero Bal.	Within $\pm 0.005\%$ RO/°C
Temp. Effect on Out.	Within $\pm 0.005\%$ /°C
Electrical Characteristics	
Safe Excit. Voltage	20 V AC or DC
Recom. Excit. Voltage	1 to 10 V AC or DC
Input Resistance	350 $\Omega \pm 0.5\%$
Output Resistance	350 $\Omega \pm 0.5\%$
Cable	4-conductor (0.3 mm ²) chloroprene shielded cable, 7.5 mm dia. by 5 m long, terminated with NDIS connector plug (Shield wire is not connected to the mainframe.)
Mechanical Properties	
Safe Overload Rating	150%
Natural Frequency	See table below.
Weight	See table below.
Protection Rating	IP 32

Dimensions

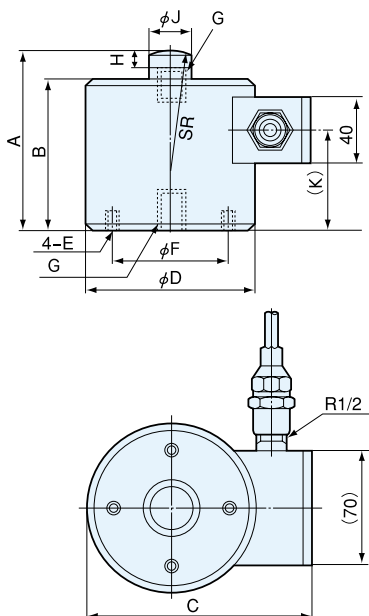

Model	Rated Capacity	Nat. Freq. (App.)	A	B	C	ϕ D	E	ϕ F	G	H	ϕ J	K	R	Weight (App.)	Saddle	Movable Saddle	Mount Base
LU-50KE	± 500 N	1.54 kHz	91.5	77.5	114	80	M5 d=8	50	M8 P=1.25 d=12	10	12	32.5	30	3.9 kg	CA-1B	ER-1B	CF-50
LU-100KE	± 1 kN	2.16 kHz															
LU-200KE	± 2 kN	3.28 kHz															
LU-500KE	± 5 kN	2.66 kHz	105	90	134	100	M8 d=8	80	M12 P=1.75 d=17	10	19	40	30	3.9 kg	CA-1B	ER-1B	CF-80
LU-1TE	± 10 kN	4.2 kHz	108	90	130	100	M8 d=12	80	M14 P=2 d=22	10	26	60	50	3.4 kg			
LU-2TE	± 20 kN	4.97 kHz	108	90	130	100	M8 d=12	80	M18 P=1.5 d=22	10	26	60	70	3.4 kg			
LU-5TE	± 50 kN	3.5 kHz	167	140	144	112	M8 d=15	95	M26 P=2 d=35	17	36	100	70	5.2 kg			
LU-10TE	± 100 kN	3.14 kHz	220	190	172.5	138	M8 d=15	120	M36 P=2 d=45	20	50	145	70	11.0 kg			
LU-20TE	± 200 kN	2.5 kHz	277	235	221	186	M8 d=15	160	M50 P=3 d=65	27	64	190	100	22.5 kg			

Dimensions in Combination

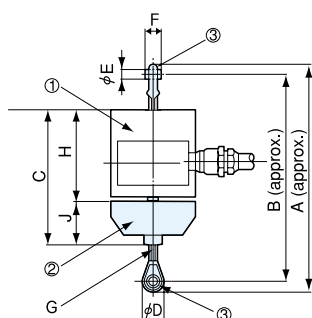

In Combination with Rotating Attachment RJ and Ball Joint TU

① Load Cell	② Rotating Attachment	③ Ball Joint	A	B	C	ϕ D	ϕ E	F	G	H	J	Static Breaking Load (Approx.)
LU-50KE	RJ-02	TU-8	217	195	125	22	8	11	M8 P=1.25	81.5	45	1.4kN
LU-100KE												2.9kN
LU-200KE												5.8kN
LU-500KE	RJ-05	TU-12	262	232	140	30	12	16	M12 P=1.75	95	45	14.7kN
LU-1TE	RJ-1	TU-14	283	246	160	37	14	17	M14 P=2	98	62	29.4kN
LU-2TE	RJ-2	TU-18	304	262	160	42	18	23	M18 P=1.5	98	62	58.8kN
LU-5TE	RJ-5	TU-26	463	393	235	70	25	37	M26 P=2	150	85	136.3kN
LU-10TE	RJ-10	TU-36										
LU-20TE	RJ-20	TU-50										

Contact us for dimensions in these cases.

Notes: 1. Rotation attachment RJ is not applicable for compression load measurement.
2. Special accessories for tension loads should be mounted at our factory.
3. Dimensions A and B are approximate, since the ball joint is screw-in type.

Compact Tension/Compression Load Cells

28 mm ϕ , Weight 80 g

LUR-A-SA1

50 N to 2 kN

Compact

Lightweight

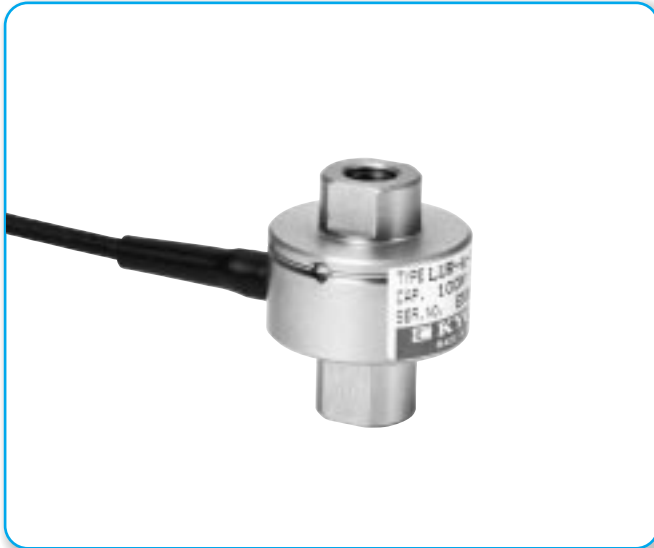

Compact and lightweight LUR-A-S1 series is easy-to-use tension/compression load cells, which can be used in various fields ranging from production lines to experiments.

Specifications

Performance	
Rated Capacity	See table below.
Nonlinearity	Within $\pm 0.5\%$ RO
Hysteresis	Within $\pm 0.5\%$ RO
Rated Output	± 0.5 mV/V (1000 $\mu\text{m/m}$) or more 50NSA1: Approx. ± 0.4 mV/V (± 800 $\mu\text{m/m}$)
Environmental Capability	
Safe Temp. Range	-10 to 70°C
Comp. Temp. Range	0 to 70°C
Temp. Effect on Zero Bal.	Within $\pm 0.05\%$ RO/ $^\circ\text{C}$ (50NSA1: Within $\pm 0.1\%$ RO/ $^\circ\text{C}$)
Temp. Effect on Out.	Within $\pm 0.05\%$ / $^\circ\text{C}$ (50NSA1: Within $\pm 0.1\%$ / $^\circ\text{C}$)
Electrical Characteristics	
Safe Excit. Voltage	7 V AC or DC
Recom. Excit. Voltage	1 to 10 V AC or DC
Input Resistance	$350 \Omega \pm 2\%$
Output Resistance	$350 \Omega \pm 2\%$
Cable	4-conductor (0.05 mm 2) chloroprene shielded cable, 3 mm dia. by 5 m long, terminated with NDIS connector plug (Shield wire is not connected to the mainframe.)
Mechanical Properties	
Safe Overload Rating	150%
Natural Frequency	See table below.
Weight	Approx. 80 g
Protection Rating	IP 40

Dimensions

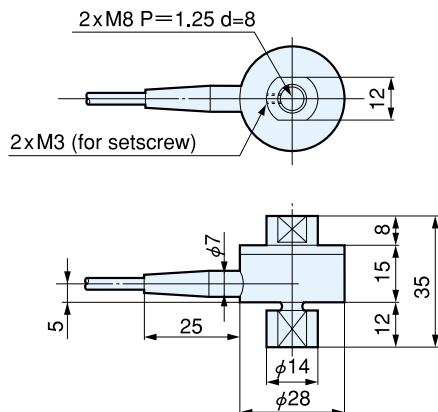

Dimensions in Combination with Ball Joint

In Combination with Ball Joint TU-B

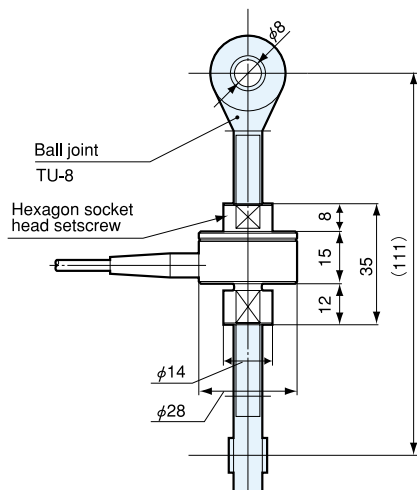

Standard Accessories Hexagon socket head setscrew M3 L=4

Model	Rated Capacity	Natural Frequency (App.)
LUR-A-50NSA1	± 50 N	2 kHz
LUR-A-100NSA1	± 100 N	4 kHz
LUR-A-200NSA1	± 200 N	5 kHz
LUR-A-500NSA1	± 500 N	9 kHz
LUR-A-1KNSA1	± 1 kN	14 kHz
LUR-A-2KNSA1	± 2 kN	20 kHz

To Ensure Safe Usage

- Consult with our sales engineer when using in combination with special accessories.
- Special accessories for tension loads should be mounted to the load cell at our factory.
- When using for tension loads, be sure to fix the load cell with accessory hexagon socket head setscrews (M3 L=4).

Note: The connector plug at the cable tip may be replaced with R05-PB5M. When ordering, suffix "-R" to the model number

Compact Tension/Compression Load Cells

Compact

LUX-B-ID

50 N to 20 kN

IP 67

Stainless Steel Made

Easy Installation

TEDS Installable



LUX-B-5 to 20KN

LUX-B-500N to 2KN

Dimensions

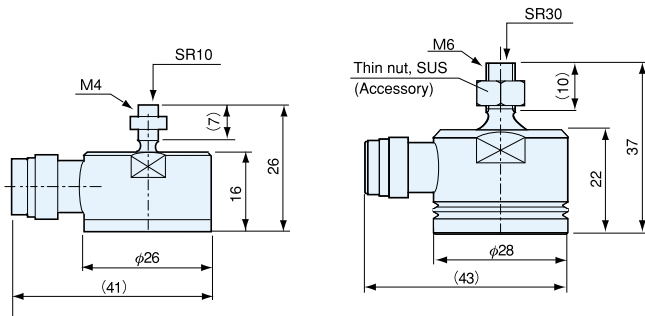

LUX-B-50N to 400N

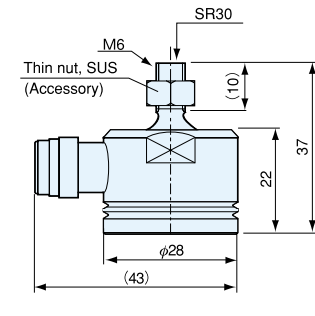

LUX-B-500N to 2KN

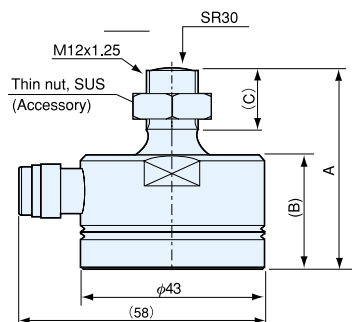
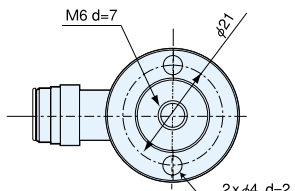
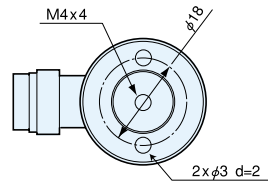

LUX-B-5KN to 20KN

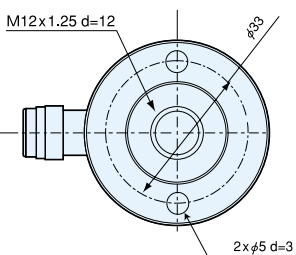

Model	A	B	C
LUX-B-5KN-ID	49	26.5	15
LUX-B-10KN-ID	51	27.5	16
LUX-B-20KN-ID	53	27	16

The LUX-A series is suitable for measuring and controlling loads applied to small-scale presses and press-fitting devices. Compact and lightweight design with screw-shape load receiving portion facilitates installation to equipment. In addition, the connector-equipped design further ensures easy installation without handling the cable together with the load cell, and easy replacement of cable.

Specifications

Performance	
Rated Capacity	See table below.
Nonlinearity	Within $\pm 0.1\%$ RO (2KN: Within $\pm 0.15\%$ RO)
Hysteresis	Within $\pm 0.1\%$ RO (2KN: Within $\pm 0.15\%$ RO)
Repeatability	0.05% RO or less
Rated Output	± 1.3 mV/V or more (500N, 1KN: 0.9 mV/V or more)
Environmental Capability	
Safe Temp. Range	-20 to 80°C
Comp. Temp. Range	-10 to 70°C
Temp. Effect on Zero Bal.	Within $\pm 0.005\%$ RO/ $^{\circ}\text{C}$
Temp. Effect on Out.	Within $\pm 0.005\%$ / $^{\circ}\text{C}$
Electrical Characteristics	
Safe Excit. Voltage	15 V AC or DC
Recom. Excit. Voltage	1 to 10 V AC or DC
Input Resistance	$350 \Omega \pm 25\%$
Output Resistance	$350 \Omega \pm 3.5\%$
Cable	4-conductor (0.08 mm ²) chloroprene shielded cable, 4 mm dia. by 4 m long, with connector plug to mainframe and bared to amplifier (Shield wire is not connected to the mainframe.)
Mechanical Properties	
Safe Overload Rating	150%
Natural Frequency	See table below.
Enclosure	SUS (metallic finish)
Weight	Approx. 0.3 kg (5 to 20KN), approx. 0. kg (500N to 2KN)
Protection Rating	IP 67 (Watertight type conforming to JIS C 0920)

Model	Rated Capacity	Natural Frequency (App.)	Recommended Tightening Torque*
LUX-B-50N-ID	± 50 N	8 kHz	3
LUX-B-100N-ID	± 100 N	11 kHz	
LUX-B-400N-ID	± 200 N	14 kHz	
LUX-B-500N-ID	± 500 N	16 kHz	10
LUX-B-1KN-ID	± 1 kN	21 kHz	
LUX-B-2KN-ID	± 2 kN	27 kHz	
LUX-B-5KN-ID	± 5 kN	18 kHz	80
LUX-B-10KN-ID	± 10 kN	21 kHz	
LUX-B-20KN-ID	± 20 kN	25 kHz	

* Tighten the oil-free part with torque wrench.

To Ensure Safe Usage

If impacts are expected in receiving tension loads, select a load cell with the rated capacity higher by one rank than the operating load.

Dimensions of Mount Base

Mount Base CX

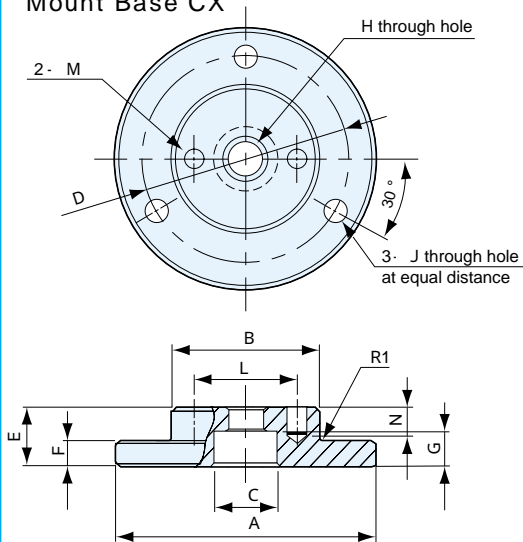

Load Cell	Mount Base	A	B	C	D	E	F	G	H	J	L	M	N	Weight (App.)
LUX-B-50N-ID	CX-2	43	26	9	35	7	2.5	4.5	4.5	5	18±0.1	3 ^{+0.20} _{+0.06}	4.5 ^{+0.2} ₀	40 g
LUX-B-100N-ID														
LUX-B-200N-ID														
LUX-B-500N-ID	CX-4	48	29	13	39	12	5	7	7	5	21±0.1	4 ^{+0.2} _{+0.1}	6	100 g
LUX-B-1KN-ID														
LUX-B-2KN-ID														
LUX-B-5KN-ID	CX-6	68	44	20	57	20	10	13	13	7	33±0.1	5 ^{+0.2} _{+0.1}	6	350 g
LUX-B-10KN-ID														
LUX-B-20KN-ID														

Hexagon socket head bolt for connection between load cell and mount base and locking pins are attached to the mount base.

Dimensions in Combination with Special Accessories

In Combination with Mount Base CX

Patch should be prepared by user or CA-2 or the equivalent should be used. This combination does not apply to tension load measurement.

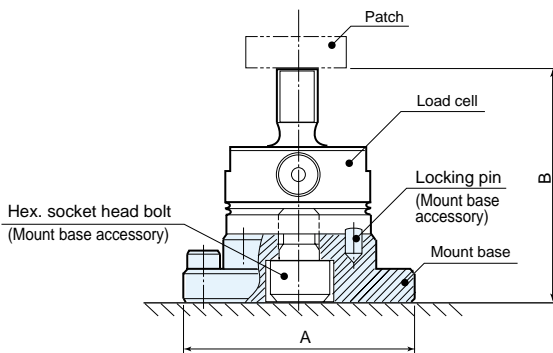

Load Cell	Mount Base	(A)	(B)
LUX-B-50N-ID	CX-2	43	33
LUX-B-100N-ID			
LUX-B-200N-ID			
LUX-B-500N-ID	CX-4	48	49
LUX-B-1KN-ID			
LUX-B-2KN-ID			
LUX-B-5KN-ID	CX-6	68	69
LUX-B-10KN-ID			71
LUX-B-20KN-ID			73

In Combination with Ball Joint TU, Whirl-stop Coupling TSC and Whirl-stop Bracket TS

This combination does not apply to compression load measurement.

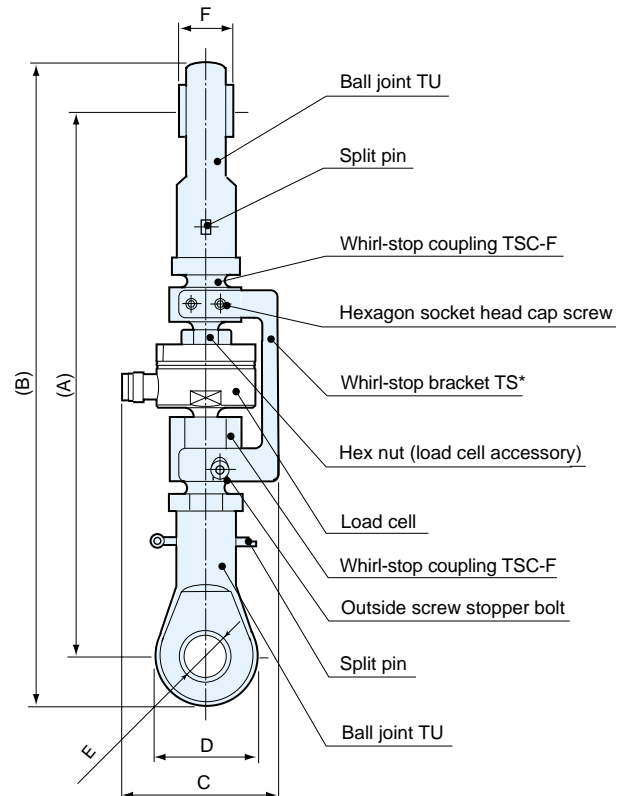

*Whirl-stop bracket is not provided with any falling prevention function. To avoid accidental hazard, install a safety device such as a link which supports the load in place of the load cell if the load cell is broken.

Load Cell	Whirl-stop Coupling	Whirl-stop Bracket	Ball Joint	(A)	(B)	C	D	φE	F
LUX-B-50N-ID	TSC-2M TSC-2F	TS-2	TU-6B	102	120	44.7	18	6	9
LUX-B-100N-ID									
LUX-B-200N-ID									
LUX-B-500N-ID	TSC-4MB TSC-4FB	TS-4B	TU-12B	165	195	50.5	30	12	16
LUX-B-1KN-ID									
LUX-B-2KN-ID									
LUX-B-5KN-ID	TSC-6MB TSC-6FB	TS-6B	TU-18B	237	279	67	42	18	23
LUX-B-10KN-ID				239	281				
LUX-B-20KN-ID				241	283				

To Ensure Safe Usage

Check the strength of the material to which the load cell is tightened. If a load cell with the rated capacity of 2 kN or more is selected, the material to which the load cell is tightened should have a tensile strength σ_b of 800 N/mm² or higher.

Typical recommended materials:

SUS 630 (H900) HRC 40 to 47

SCM 434 HRC 30 to 38

For tension load measurement, take care never to exceed the safe overload rating.

LUX-B-ID Safe Bending Moment (N-mm)

Figures below show the safe bending moment against lateral load with a load applied in sensitivity direction (vertical direction)

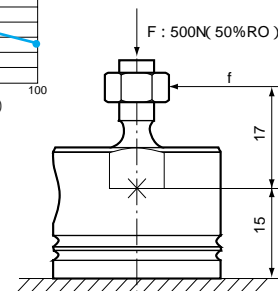
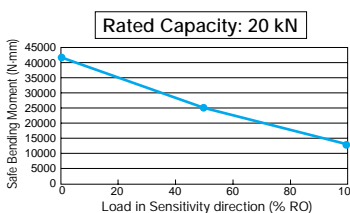
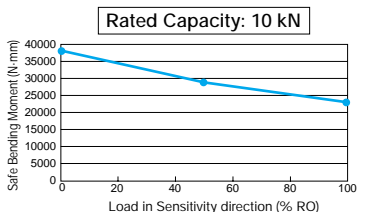
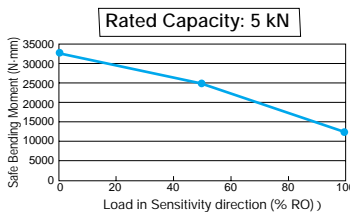
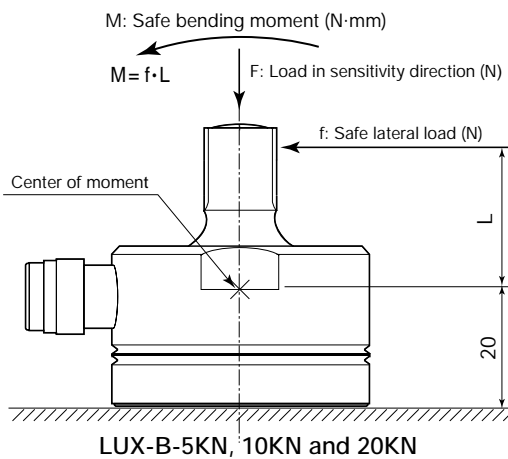
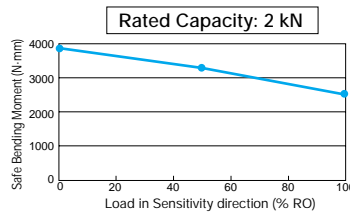
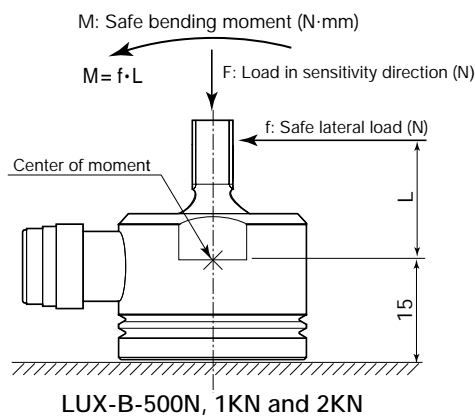
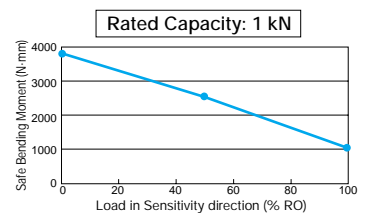
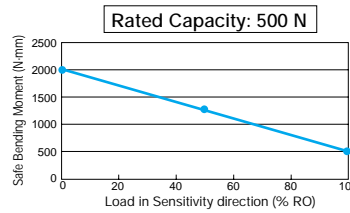
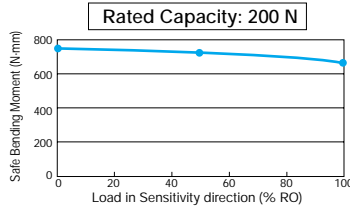
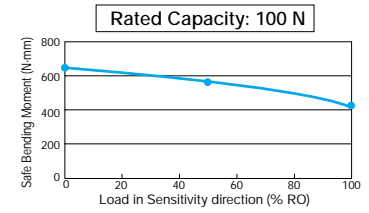
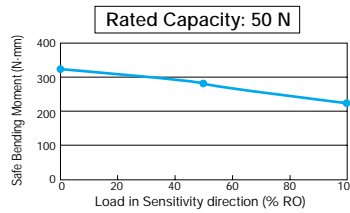
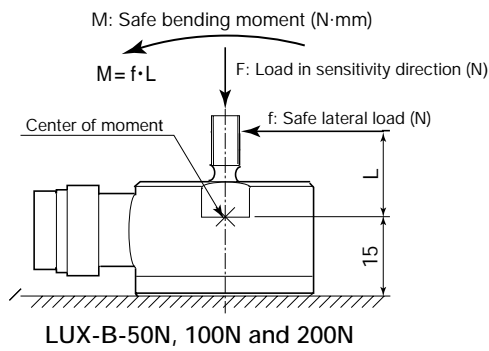

How to Obtain Safe Lateral Load

Shown here is an example of calculating the safe lateral load when the LUX-A-1kN receives a load in sensitivity direction (vertical direction). (See Fig. 1.)

The safe lateral load f (N) which can be applied to the screw at the distance of 17 mm from the center of moment when a load of 500 N (50% the rated capacity) is applied in sensitivity direction is obtained as follows:

According to Graph-1, safe bending moment, M , is approximately 2500 N-m when a load of 50% the rated capacity is applied in sensitivity direction. Since the relation between safe lateral load f , and safe bending moment M is $M = f \cdot L$,

$$f = \frac{M}{L} = \frac{2500}{17} = 147.1 \text{ N}$$

Therefore, the safe lateral load f is 147.1 N.

Note: Safe lateral load is an allowable load to the mechanical strength of the load cell but it does not guarantee the accuracy.

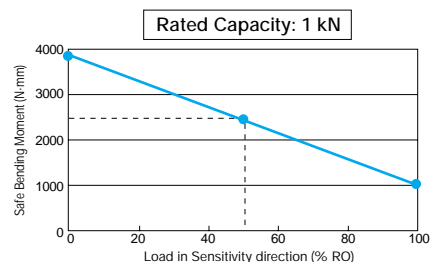

Graph-1

LU-A

50 to 200 N

Small Capacity

High Accuracy



• TEDS-installed versions can be manufactured. Inquiries are welcome.

A straight beam is used for the strain column to enable highly accurate measurement of small loads.

Specifications

Performance	
Rated Capacity	See table below.
Nonlinearity	Within $\pm 0.3\%$ RO
Hysteresis	Within $\pm 0.2\%$ RO
Repeatability	0.2% RO or less
Rated Output	1.5 mV/V (3000 $\mu\text{m/m}$) $\pm 5\%$
Environmental Capability	
Safe Temp. Range	-20 to 75°C
Comp. Temp. Range	-10 to 65°C
Temp. Effect on Zero Bal.	Within $\pm 0.01\%$ RO/°C
Temp. Effect on Out.	Within $\pm 0.01\%$ /°C
Electrical Characteristics	
Safe Excit. Voltage	15 V AC or DC
Recom. Excit. Voltage	1 to 10 V AC or DC
Input Resistance	350 $\Omega \pm 0.5\%$
Output Resistance	350 $\Omega \pm 0.5\%$
Cable	4-conductor (0.3 mm ²) chloroprene shielded cable, 7.6 mm dia. by 5 m long, terminated with NDIS connector plug (Shield wire is not connected to the mainframe.)
Mechanical Properties	
Safe Overload Rating	120%
Natural Frequency	See table below.
Weight	Approx. 2.3 kg
Protection Rating	IP 32

Model	Rated Capacity	Natural Frequency (Approx.)
LU-5KA	± 50 N	200 Hz
LU-10KA	± 100 N	330 Hz
LU-20KA	± 200 N	500 Hz

Dimensions

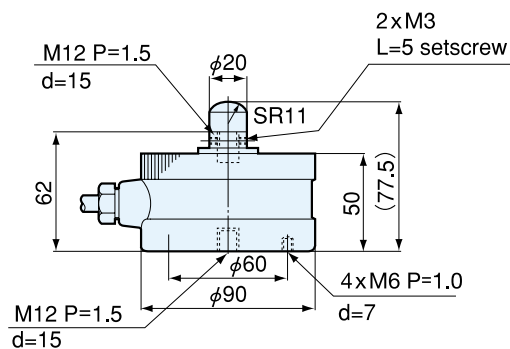

Dimensions in Combination with Mount Base

● In Combination with Mount Base CF-60

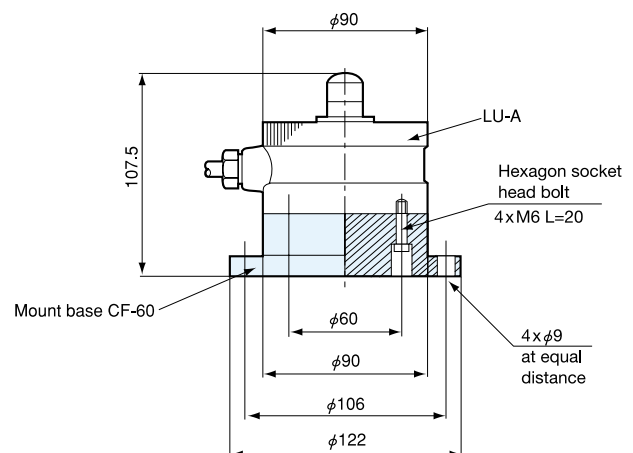

Hexagon socket head bolts for connection between load cell and mount base are standard accessories to mount base.

LUH-F

500 N to 200 kN

Measurement of both tension and compression loads

Excellent zero float characteristics (50 to 500KF)

Remote sensing possible

• Ball joint is required for tension load measurement.

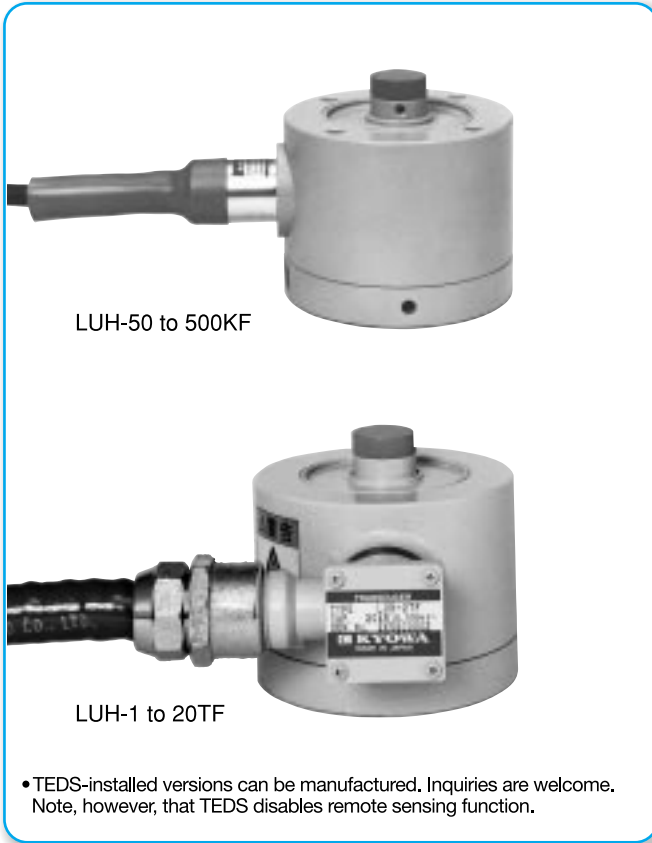

LUH-F series is tension/compression load cells featuring 1/5000 accuracy. The hermetically-sealed structure with inert gas filled in ensures stable characteristics. For remote sensing, refer to page 3.

Specifications

Performance	
Rated Capacity	See table below.
Nonlinearity	Within $\pm 0.02\%$ RO
Hysteresis	Within $\pm 0.02\%$ RO
Repeatability	0.02% RO or less
Zero Float	0.02% RO or less (50 to 500KF)
Rated Output	2 mV/V (4000 $\mu\text{m/m}$) $\pm 0.1\%$
Environmental Capability	
Safe Temp. Range	-35 to 80°C
Comp. Temp. Range	-10 to 60°C
Temp. Effect on Zero Bal.	Within $\pm 0.0015\%$ RO/ $^\circ\text{C}$
Temp. Effect on Out.	Within $\pm 0.001\%$ / $^\circ\text{C}$
Electrical Characteristics	
Safe Excit. Voltage	20 V AC or DC
Recom. Excit. Voltage	1 to 10 V (1TF to 20TF: 1 to 12 V) AC or DC)
Input Resistance	$350 \Omega \pm 0.5\%$
Output Resistance	$350 \Omega \pm 0.5\%$
Cable	6-conductor (0.5 mm ²) chloroprene shielded cable, 9.5 mm dia. by 5 m long, with press-fit terminal for 4 mm (Shield wire is not connected to the mainframe.)
Mechanical Properties	
Safe Overload Rating	150%
Natural Frequency	See table below.
Weight	See table below.
Others	Drop prevention stopper mountable Critical overload 1000% (50 to 500KF)
Protection Rating	IP 67 (Watertight type conforming to JIS C0920)

Standard Accessories

4 hexagon socket head setscrews M5 L=10 mm (30 mm with LUH-10TF and 20TF)
1 hexagon bar (opposite side 25 mm)

Model	Rated Capacity	Natural Frequency (App.)	Weight (App.)
LUH-50KF	± 500 N	1.4 kHz	2.1 kg
LUH-100KF	± 1 kN	2.2 kHz	
LUH-200KF	± 2 kN	3.1 kHz	
LUH-500KF	± 5 kN	4.6 kHz	
LUH-1TF	± 10 kN	4.2 kHz	4.8 kg
LUH-2TF	± 20 kN	6 kHz	4.6 kg
LUH-5TF	± 50 kN	5.2 kHz	9.6 kg
LUH-10TF	± 100 kN	4.5 kHz	19 kg
LUH-20TF	± 200 kN	3.7 kHz	38 kg

ZERO FLOAT

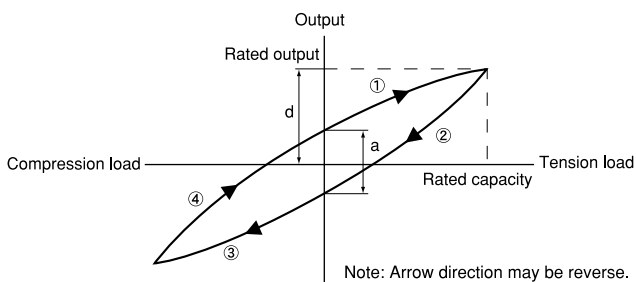

$$\text{Zero Float} = \frac{a}{d} \times 100 (\% \text{ RO})$$

Zero float means such a phenomenon that a cycle of continuously applied tension and compression loads causes the zero to float. The value is expressed in percentage of the rated output. It is also called cyclic zero shift.

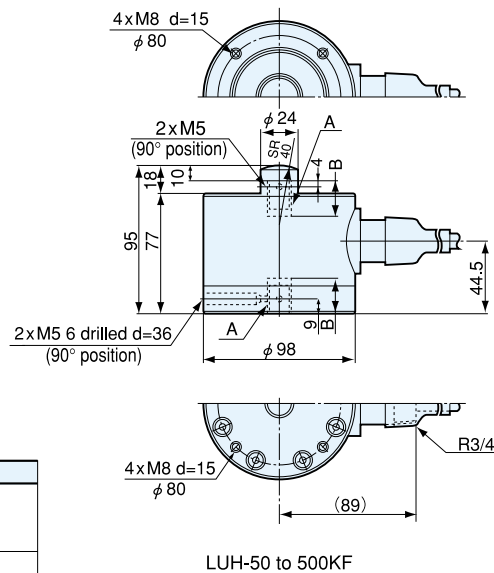

Model	A	B
LUH-50KF	M12 P=1.75	17
LUH-100KF		
LUH-200KF		
LUH-500KF	M18 P=1.5	22

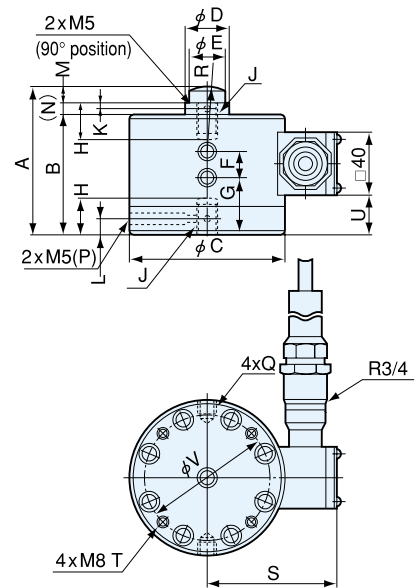

LUH-1 to 20TF

Model	A	B	φC	φD	φE	F	G	H	J	K	L	M	N	P	Q	R	S	T	U	φV	Ball Joint
LUH-1TF	95	77	100	24	24	20	35	22	M14 P=2	4	9	10	8	6 drilled d=36	M8 d=10	SR40	84.5	d=12	24.5	80	TU-14
LUH-2TF	95	77	100	24	24	20	35	22	M18 P=1.5	4	9	10	8	6 drilled d=36	M8 d=10	SR40	84.5	d=12	24.5	80	TU-18
LUH-5TF	127	100	130	36	36	30	50	30	M26 P=2	5	13	17	10	9 drilled d=42	M16 d=16	SR60	99.5	d=15	40	95	TU-26
LUH-10TF	170	135	160	50	50	40	60	45	M36 P=2	8	17	20	15	9 drilled d=54	M20 d=15	SR70	115.5	d=15	60	120	TU-36
LUH-20TF	228	175	200	68	64	50	80	65	M50 P=3	12	23	28	25	9 drilled d=65	M24 d=20	SR100	135.5	d=15	80	160	TU-50

LUH-50 to 500KF Dimensions in Combination with Special Accessories

● When using in combination with special accessories, consult with our sales engineer.

Note: Special accessories for tension load measurement should be assembled at our factory.

● In Combination with Saddle CA and Mount Base CF

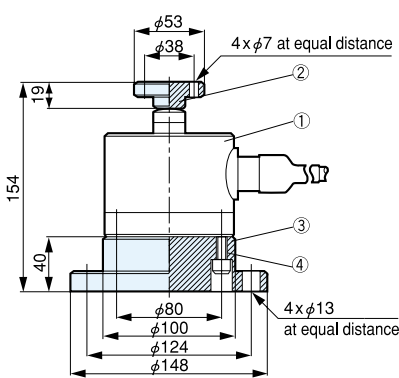

- ① Load cell LUH-F
- ② Saddle CA-2B
- ③ Mount base CF-80
- ④ Hexagon socket head bolt 4-M8 L=30 (included in standard accessories of mount base)

● In Combination with Movable Saddle ER and Mount Base CF

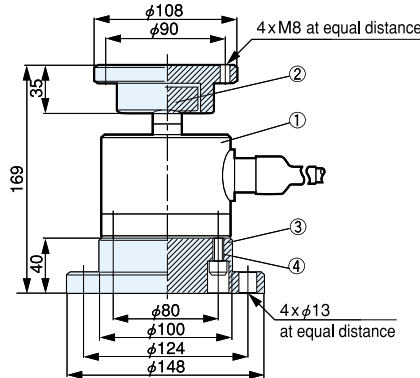

- ① Load cell LUH-F
- ② Movable saddle ER-2B
- ③ Mount base CF-80
- ④ Hexagon socket head bolt 4-M8 L=30 (included in standard accessories of mount base)

● In Combination with Ball Joint TU

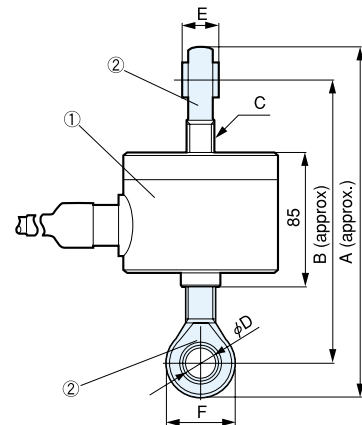

① Load Cell	② Ball Joint	A	B	C	D	E	F	Static Breaking Load (Approx.)
LUH-50KF	TU-12	207	177	M12 P=1.75	12	16	30	1.4 kN
LUH-100KF	TU-12	207	177	M12 P=1.75	12	16	30	2.9 kN
LUH-200KF	TU-12	207	177	M12 P=1.75	12	16	30	5.8 kN
LUH-500KF	TU-18	231	189	M18 P=1.5	18	23	42	14.7 kN

Note: From the viewpoint of guaranteed accuracy, hook and shackle cannot be combined.

Spacers and attachments for replacement with LC-G and LT-G series load cells (500 N to 5 kN)

Model	Replacement Spacer	Replacement Attachment
LC-50 to 500KG	CFS-1GC	—
LT-50 to 200KG	CFS-500GT	—
LT-500KG	CFS-500GT	TUA-500GT

Note: For the LT-500KG, installation dimensions should be changed.

Beam-Type Load Cells

Nonlinearity 1/3333 (50 to 500N)

LUB-B

50 N to 20 kN

Compact and Lightweight

Metal Bellows

Nonlinearity 1/3333^{*1}

Special Steel Body^{*1}

Corrosion-Resistant^{*2}

^{*1}: 5 to 50KB ^{*2}: 100KB to 2TB

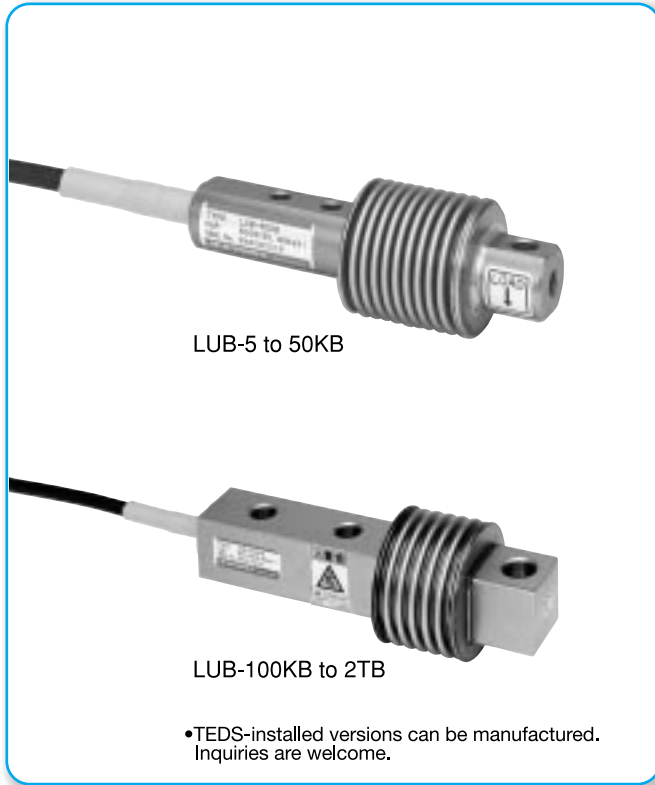

LUB-5KB to 50KB feature an accuracy of 1/3333 and LUB-100KB to 2TB feature corrosion-resistant stainless steel body and bellows. As load detectors, they enable configuration of accurate and stable weighing systems for conveyors and tanks.

Specifications

Performance	
Rated Capacity	See table below.
Nonlinearity	Within $\pm 0.03\%$ RO (100KB to 2TB: Within $\pm 0.05\%$ RO)
Hysteresis	Within $\pm 0.03\%$ RO (100KB to 2TB: Within $\pm 0.05\%$ RO)
Repeatability	0.03% RO or less
Rated Output	2 mV/V (4000 $\mu\text{m/m}$) $\pm 0.3\%$
Environmental Capability	
Safe Temp. Range	-20 to 70°C
Comp. Temp. Range	-10 to 60°C
Temp. Effect on Zero Bal.	Within $\pm 0.003\%$ RO/°C
Temp. Effect on Out.	Within $\pm 0.003\%$ /°C
Electrical Characteristics	
Safe Excit. Voltage	20 V AC or DC
Recom. Excit. Voltage	1 to 12 V AC or DC
Input Resistance	435 $\Omega \pm 60 \Omega$ (100KB to 2TB: 400 $\Omega \pm 50 \Omega$)
Output Resistance	350 $\Omega \pm 2 \Omega$
Cable	4-conductor (0.3 mm ²) chloroprene shielded cable, 7.6 mm dia, by 3 m long (100KB to 2TB: 5 m long), bared at the tip (Shield wire is not connected to the mainframe.)

In Combination with Special Accessories

- LUB-B in combination with mount base with stopper

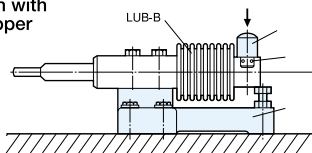

- LUB-B/C in combination with spacer

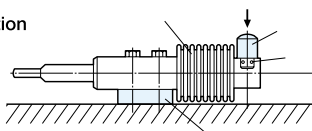

- LUB-B/C in combination with hanger

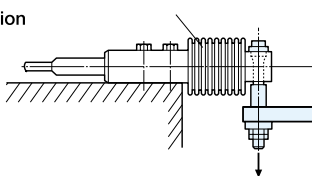

Mechanical Properties

Safe Overload Rating	150%
Natural Frequency	See table below.
Weight	See table below.
Protection Rating	IP 67 (Watertight type conforming to JIS C 0920)

Dimensions

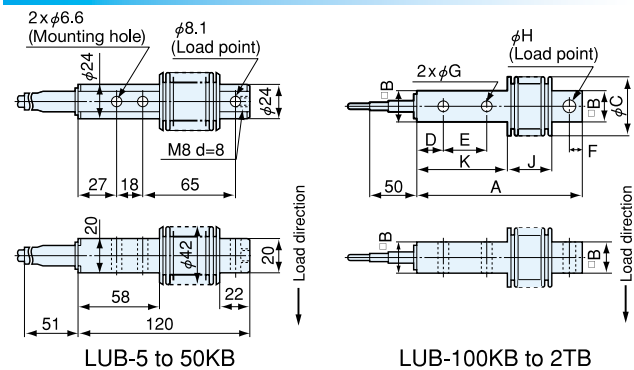

Model	Rated Capacity	Natural Frequency (App.)	A	B	ϕC	D	E	F	ϕG	ϕH	J	K	Weight (App.)	Patch	Mount Base w/Stopper	Spacer	Hanger
LUB-5KB	50 N	250 Hz	See dimensional drawing above.										530 g	CW-005	LD-005	LE-005	TW-002 (for 5 to 20KB)
LUB-10KB	100 N	350 Hz															TW-005 (for 5 to 50KB)
LUB-20KB	200 N	500 Hz															
LUB-30KB	300 N	650 Hz															
LUB-50KB	500 N	800 Hz															
LUB-100KB	1 kN	1.8 kHz	120	20	42	25	20	10	8.4	10.1	36	60	800 g	CW-02	—	LE-02	TW-02
LUB-200KB	2 kN	1.9 kHz	190	35	67	30	50	15	13	16.1	45	110	1.9 kg	CW-1	—	LE-1	TW-1
LUB-500KB	5 kN	1.1 kHz	220	44	84	30	60	20	17	20.2	54	124	3.2 kg	CW-2	—	LE-2	TW-2

LUB-C

5 kN, 20 kN

Low Price

Compact and Lightweight

Nonlinearity 1/2000



Developed as OEM-oriented industrial beam-type load cells with accuracy of 1/2000. As load detectors, LUB-C series enables configuration of accurate and stable weighing systems for conveyors and tanks.

Specifications

Performance	
Rated Capacity	See table below.
Nonlinearity	Within $\pm 0.05\%$ RO
Hysteresis	Within $\pm 0.05\%$ RO
Repeatability	0.03% RO or less
Rated Output	2 mV/V (4000 $\mu\text{m/m}$) $\pm 0.5\%$
Environmental Capability	
Safe Temp. Range	-20 to 70°C
Comp. Temp. Range	-10 to 60°C
Temp. Effect on Zero Bal.	Within $\pm 0.003\%$ RO/°C
Temp. Effect on Out.	Within $\pm 0.003\%$ /°C
Electrical Characteristics	
Safe Excit. Voltage	20 V AC or DC
Recom. Excit. Voltage	1 to 12 V AC or DC
Input Resistance	380 $\Omega \pm 8\%$
Output Resistance	350 $\Omega \pm 1\%$
Cable	4-conductor (0.14 mm ²) chloroprene shielded cable, 6 mm dia. by 2 m long, bared at the tip (Shield wire is not connected to the mainframe.)
Mechanical Properties	
Safe Overload Rating	150%
Natural Frequency	See table below.
Weight	See table below.
Protection Rating	IP 64 (Splashproof type conforming to JIS C 0920)

Dimensions

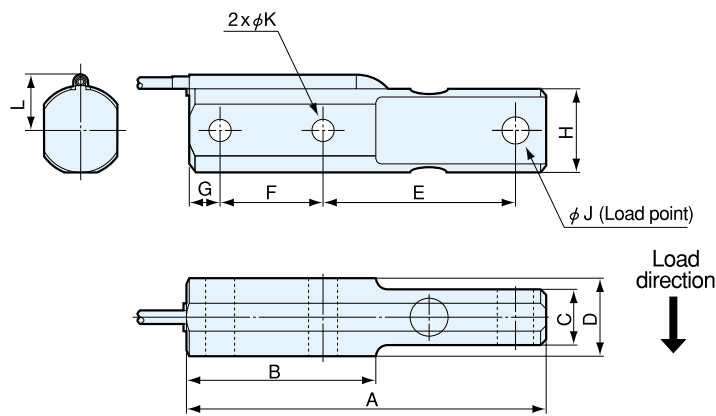

LUB-500KC, 2TC

Model	Rated Capacity	Natural Frequency (App.)	A	B	C	D	E	F	G	H	ϕ J	ϕ K	L	Weight (App.) including cable	Patch	Spacer	Hanger
LUB-500KC	5 kN	1.3 kHz	174	88	23.4	35	95	50	14	38	16.1	14	27	1.3 kg	CW-1	LE-1	TW-1
LUB-2TC	20 kN	1.3 kHz	206	106	32.6	44	110	60	16	53	20.2	18	34	2.7 kg	CW-2	LE-2	TW-2

LVS-A

50 mN to 20 N

Compact and Lightweight

High Accuracy

Easy to Handle



•TEDS-installed versions can be manufactured. Inquiries are welcome.

LVS-A series is designed to accurately measure small loads ranging from 50 mN to 20 N. Easy to install and handle, load cells in the LVS-A series measures loads in vertical direction to the mounted surface.

Specifications

Performance		
Rated Capacity	Model	Rated Capacity
	LVS-5GA	50 mN
	LVS-10GA	100 mN
	LVS-20GA	200 mN
	LVS-50GA	500 mN
	LVS-100GA	1 N
	LVS-200GA	2 N
	LVS-500GA	5 N
Critical Overload Rating	LVS-1KA	10 N
	LVS-2KA	20 N
Nonlinearity		
Within $\pm 0.5\%$ RO		
Hysteresis		
Within $\pm 0.5\%$ RO		
Repeatability		
0.5% RO or less		
Rated Output		
1.5 mV/V (3000 $\mu\text{m/m}$) or more		
5 and 10GA: 1.2 mV/V (2400 $\mu\text{m/m}$) or more		
Environmental Capability		
Safe Temp. Range		
-10 to 70°C		
Comp. Temp. Range		
0 to 60°C		
Temp. Effect on Zero Bal.		
Within $\pm 0.05\%$ RO/°C		
Temp. Effect on Out.		
Within $\pm 0.1\%$ /°C		
Electrical Characteristics		
Safe Excit. Voltage		
6 V AC or DC		
Recom. Excit. Voltage		
1 to 2 V AC or DC		
Input Resistance		
120 $\Omega \pm 10\%$		
Output Resistance		
120 $\Omega \pm 10\%$		
Cable		
4-conductor (0.05 mm ²) chloroprene shielded cable, 3 mm dia. by 1 m long, terminated with NDIS connector plug (Shield wire is not connected to the mainframe.)		
Mechanical Properties		
Safe Overload Rating		
120%		
Natural Frequency		
See table below.		
Weight		
Approx. 50 g		
Protection Rating		
IP 30		

Dimensions

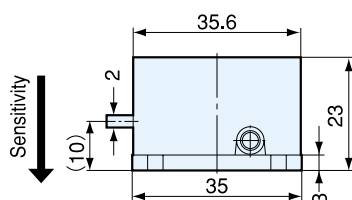
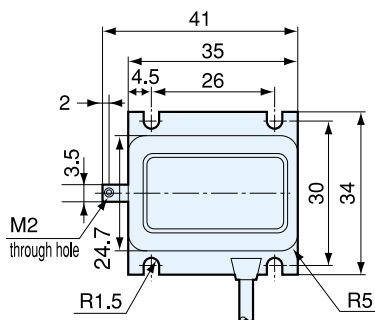

To Ensure Safe Usage

- The load cell should be carefully installed. Especially, never apply any impact (force) in sensitivity direction.
 - When mounting the rod to the measuring object, do not apply any bending or twisting force to it.
- Note: LVS-A M1 which is interchangeable with T-B (old version of LVS-A) can also be manufactured, Inquiries are welcome.

Ultrasmall-Capacity Load Cells

Compact and Lightweight

LTS-A

500 mN to 20 N

Compact and Lightweight

High Accuracy

Easy to Handle



•TEDS-installed versions can be manufactured. Inquiries are welcome.

LTS-A series is designed to accurately measure small loads ranging from 50 mN to 20 N. Easy to install and handle, load cells in the LTS-A series measures loads in horizontal direction to the mounted surface.

Specifications

Performance			
Rated Capacity	Model	Rated Capacity	Critical Overload Rating
	LTS-50GA	500 mN	500%
	LTS-100GA	1 N	
	LTS-200GA	2 N	
	LTS-500GA	5 N	250%
	LTS-1KA	10 N	
LTS-2KA	20 N		
Nonlinearity	Within $\pm 0.5\%$ RO		
Hysteresis	Within $\pm 0.5\%$ RO		
Repeatability	0.5% RO or less		
Rated Output	1.5 mV/V (3000 $\mu\text{m/m}$) or more		
Environmental Capability			
Safe Temp. Range	-10 to 70°C		
Comp. Temp. Range	0 to 60°C		
Temp. Effect on Zero Bal.	Within $\pm 0.005\%$ RO/°C		
Temp. Effect on Out.	Within $\pm 0.1\%$ /°C		
Electrical Characteristics			
Safe Excit. Voltage	6 V AC or DC		
Recom. Excit. Voltage	1 to 2 V AC or DC		
Input Resistance	120 $\Omega \pm 10\%$		
Output Resistance	120 $\Omega \pm 10\%$		
Cable	4-conductor (0.05 mm ²) chloroprene shielded cable, 3 mm dia. by 1 m long, terminated with NDIS connector plug (Shield wire is not connected to the mainframe.)		
Mechanical Properties			
Safe Overload Rating	120%		
Natural Frequency	See table below.		
Weight	Approx. 50 g		
Protection Rating	IP 30		

Dimensions

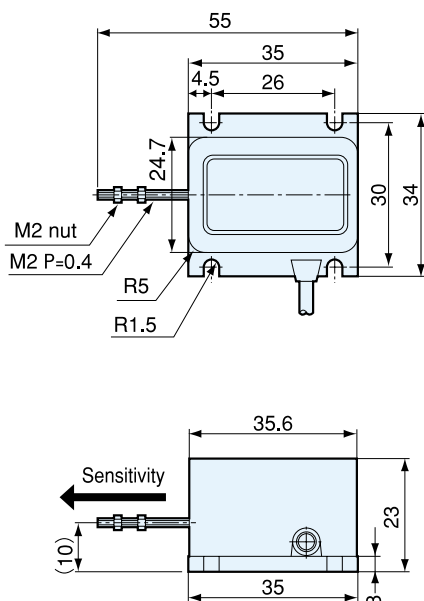

To Ensure Safe Usage

- The load cell should be carefully installed. Especially, never apply any impact (force) in sensitivity direction.
- When mounting the rod to the measuring object, do not apply any bending or twisting force to it.

Note: LTS-A M1 which is interchangeable with T-D (old version of LTS-A) can also be manufactured, Inquiries are welcome.

LUK-A

5 kN to 2 MN

Thin

High Accuracy

High Stability

Hermetically-Sealed Structure with Inert Gas Filled in



The thin structure is suitable for installation where the height is limited. The service life can be extended by using with one-half the rated capacity if repetitive loads are applied continuously.

Specifications

Performance																									
Rated Capacity	See table below.																								
Nonlinearity	Within $\pm 0.1\%$ RO (500KN to 2MN: Within $\pm 0.2\%$ RO)																								
Hysteresis	Within $\pm 0.1\%$ RO (500KN to 2MN: Within $\pm 0.2\%$ RO)																								
Repeatability	0.05% RO or less (500KN to 2MN: 0.1% RO or less)																								
Rated Output	± 2 mV/V (± 4000 $\mu\text{m/m}$) $\pm 1\%$ (5 to 20KN: $\pm 10\%$)																								
Environmental Capability																									
Safe Temp. Range	-35 to 80°C																								
Comp. Temp. Range	-10 to 70°C																								
Temp. Effect on Zero Bal.	Within $\pm 0.005\%$ RO/ $^\circ\text{C}$																								
Temp. Effect on Out.	Within $\pm 0.005\%$ / $^\circ\text{C}$																								
Electrical Characteristics																									
Safe Excit. Voltage	15 V AC or DC																								
Recom. Excit. Voltage	1 to 10 V AC or DC																								
Input Resistance	$350 \Omega \pm 1\%$ (5 to 20KN: $375 \Omega \pm 3\%$)																								
Output Resistance	$350 \Omega \pm 1\%$																								
Cable	4-conductor (0.3 mm^2) chloroprene shielded cable, 7.6 mm dia. by 5 m long, terminated with NDIS connector plug (Shield wire is not connected to the mainframe.)																								
Mechanical Properties																									
Safe Overload Rating	150%																								
Natural Frequency	<table border="1"> <thead> <tr> <th>Model</th> <th>Nat. Freq. (App.)</th> <th>Model</th> <th>Nat. Freq. (App.)</th> </tr> </thead> <tbody> <tr> <td>LUK-A-5KN</td> <td>7.4 kHz</td> <td>LUK-A-200KN</td> <td>7.5 kHz</td> </tr> <tr> <td>LUK-A-10KN</td> <td>10.8 kHz</td> <td>LUK-A-500KN</td> <td>5.2 kHz</td> </tr> <tr> <td>LUK-A-20KN</td> <td>8.5 kHz</td> <td>LUK-A-1MN</td> <td>5 kHz</td> </tr> <tr> <td>LUK-A-50KN</td> <td>11 kHz</td> <td>LUK-A-2MN</td> <td>3.9 kHz</td> </tr> <tr> <td>LUK-A-100KN</td> <td>9 kHz</td> <td></td> <td></td> </tr> </tbody> </table>	Model	Nat. Freq. (App.)	Model	Nat. Freq. (App.)	LUK-A-5KN	7.4 kHz	LUK-A-200KN	7.5 kHz	LUK-A-10KN	10.8 kHz	LUK-A-500KN	5.2 kHz	LUK-A-20KN	8.5 kHz	LUK-A-1MN	5 kHz	LUK-A-50KN	11 kHz	LUK-A-2MN	3.9 kHz	LUK-A-100KN	9 kHz		
Model	Nat. Freq. (App.)	Model	Nat. Freq. (App.)																						
LUK-A-5KN	7.4 kHz	LUK-A-200KN	7.5 kHz																						
LUK-A-10KN	10.8 kHz	LUK-A-500KN	5.2 kHz																						
LUK-A-20KN	8.5 kHz	LUK-A-1MN	5 kHz																						
LUK-A-50KN	11 kHz	LUK-A-2MN	3.9 kHz																						
LUK-A-100KN	9 kHz																								
Weight	See table below.																								
Protection Rating	IP 64 (Splashproof type conforming to JIS C0920)																								
Safe Lateral Force Component	See table below.																								
Safe Moment	See table below.																								

To Ensure Safe Usage

Be sure to prevent the shaft from turning when using for hanging load measurement.

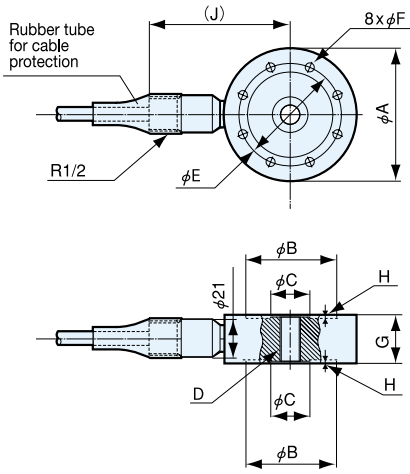

LUK-5 to 20KN

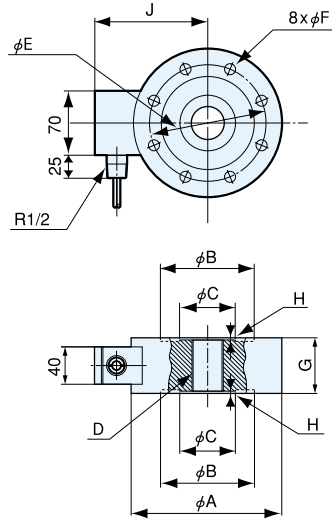

LUK-A-50 to 500KN

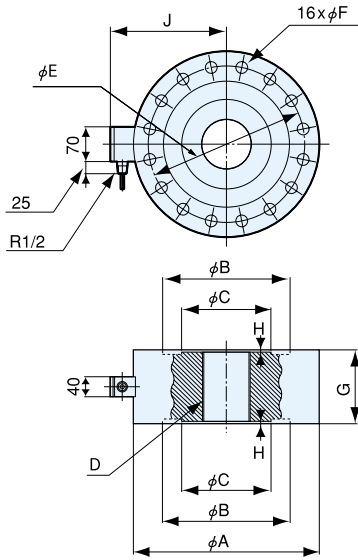

LUK-A-1 to 2MN

Installation Example

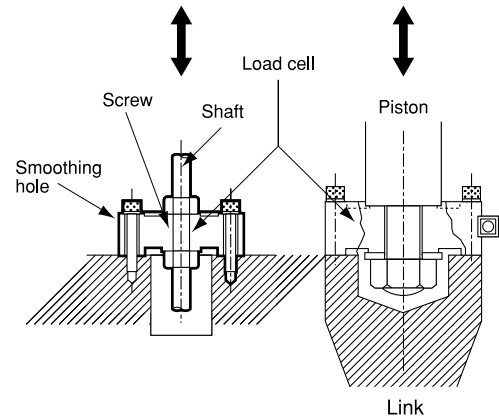

Model	Rated Capacity	Safe Moment	Safe Lateral Force Component	φA	φB	φC	D	φE	φF	G	H	J (App.)	Weight (App.)
LUK-A-5KN	±5 kN	15 N·m	250 N	77	52	20	M12 P=1.75	62	7	30	1	82	900 g
LUK-A-10KN	±10 kN	30 N·m	500 N										
LUK-A-20KN	±20 kN	60 N·m	1 kN	107	70	34	M18 P=1.5	85	9	40	1	97	2.7 kg
LUK-A-50KN	±50 kN	150 N·m	2.5 kN	127	77	40	M24 P=1.5	95	13	50	2	102	4.3 kg
LUK-A-100KN	±100 kN	500 N·m	5 kN	157	100	60	M36 P=2	125	17	60	2	119	7.5 kg
LUK-A-200KN	±200 kN	1 kN·m	10 kN	227	136	90	M50 P=2	180	22	70	2	157	20 kg
LUK-A-500KN	±500 kN	2.5 kN·m	25 kN	307	200	138	M76 P=3	256	26	105	3	198	50 kg
LUK-A-1MN	±1 MN	5 kN·m	50 kN	375	254	180	M100 P=3	314	26	150	3	233	90 kg
LUK-A-2MN	±2 MN	10 kN·m	100 kN	560	410	260	M150 P=4	485	36	200	3	326	245 kg

Compact 6-Component Force Transducers

Compact and Lightweight

LFM-A

1 kN, 3 kN

Compact

Center Hole Type

High Sensitivity



Enables simultaneous measurement of 3 forces (F_x , F_y , F_z) in 3 axial directions orthogonal to the transducer and 3 moments (M_x , M_y , M_z) around the axes. An 8-channel measuring instrument amplifies the transducer's 8 output components in strain quantity and calculates 6-component force.

Specifications

Performance	
Rated Capacity	See table at the right.
Linearity	Within $\pm 0.5\%$ RO
Hysteresis	Within $\pm 0.5\%$ RO
Interference	$\pm 1.5\%$ RO (after correction by attached correction coefficient)
Rated Output	See table at the right.
Environmental Capability	
Safe Temp. Range	-10 to 70°C (noncondensing)
Comp. Temp. Range	0 to 60°C (noncondensing)
Temp. Effect on Zero Bal.	Within $\pm 0.05\%$ RO/ $^\circ\text{C}$
Temp. Effect on Out.	Within $\pm 0.05\%$ / $^\circ\text{C}$

Electrical Characteristics	
Safe Excit. Voltage	12 V AC or DC
Recom. Excit. Voltage	1 to 5 V AC or DC
Input/Output Resistance	$350 \Omega \pm 1\%$
Cable	16-conductor (0.11 mm^2) twisted pair vinyl shielded cable, 6.6 mm dia. by 55 cm long, braed at the tip
Mechanical Properties	
Safe Overload Rating	150%
Casing Material	Main unit (LFM-A-1KN): Aluminum (metallic finish) Main unit (LFM-A-3KN): SUS (metallic finish) Cover: Black anodic oxide coating aluminum Cable holder: Anodic oxide coating aluminum
Weight	See table below.
Protection Rating	IP 40

Model	Rated Capacity	Rated Output	Weight (Approx.)
LFM-A-1KN	FX : $\pm 1000 \text{ N}$	FX : $\pm 1.5 \text{ mV/V}$ or more	160 g
	FY : $\pm 1000 \text{ N}$	FY : $\pm 1.5 \text{ mV/V}$ or more	
	FZ : $\pm 1000 \text{ N}$	FZ : $\pm 1.8 \text{ mV/V}$ or more	
	MX : $\pm 50 \text{ N}\cdot\text{m}$	MX : $\pm 4.0 \text{ mV/V}$ or more	
	MY : $\pm 50 \text{ N}\cdot\text{m}$	MY : $\pm 4.0 \text{ mV/V}$ or more	
	MZ : $\pm 25 \text{ N}\cdot\text{m}$	MZ : $\pm 2.4 \text{ mV/V}$ or more	
LFM-A-3KN	FX : $\pm 3000 \text{ N}$	FX : $\pm 1.6 \text{ mV/V}$ or more	360 g
	FY : $\pm 3000 \text{ N}$	FY : $\pm 1.6 \text{ mV/V}$ or more	
	FZ : $\pm 3000 \text{ N}$	FZ : $\pm 1.6 \text{ mV/V}$ or more	
	MX : $\pm 100 \text{ N}\cdot\text{m}$	MX : $\pm 2.4 \text{ mV/V}$ or more	
	MY : $\pm 100 \text{ N}\cdot\text{m}$	MY : $\pm 2.4 \text{ mV/V}$ or more	
	MZ : $\pm 50 \text{ N}\cdot\text{m}$	MZ : $\pm 1.6 \text{ mV/V}$ or more	

Dimensions

Note: The center hole (42 mm diameter) is to pass wires and the like. But do not contact wires or any metal part with the inner wall. Such contact deteriorates the performance characteristics while damaging the protective tape of the inner wall and the internal components of the transducer.

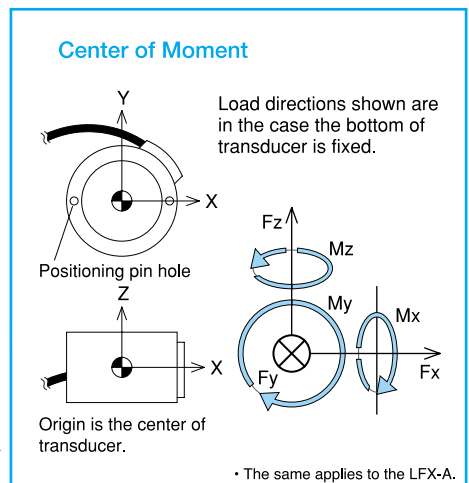
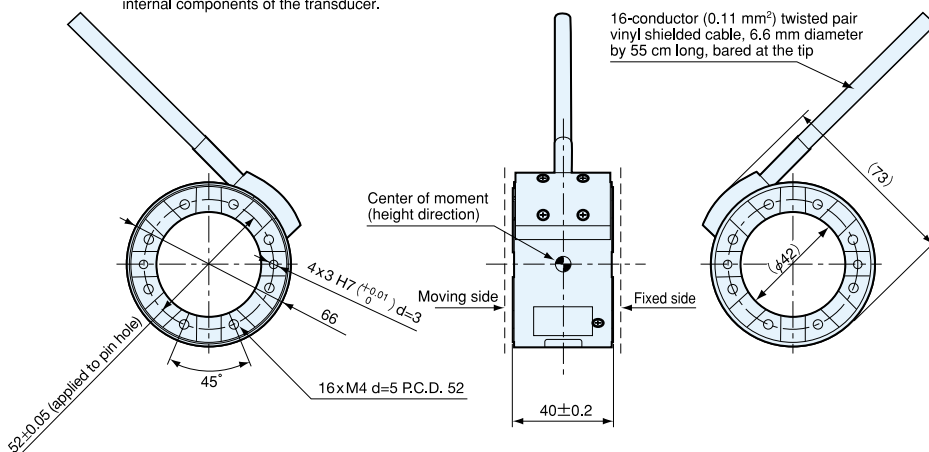

Original point and moment center of x-, y- and z-axes coincide with transducer height and circumferential center.

Compact 6-Component Force Transducers with Built-in Amplifier

Compact

LFX-A

1 kN, 3 kN

Compact

Amplifier Built in

Wiring Hole at the Center (4 mm ϕ)



Enables simultaneous measurement of 3 forces (F_x , F_y , F_z) in 3 axial directions orthogonal to the transducer and 3 moments (M_x , M_y , M_z) around the axes. It outputs 6 voltage signals proportionated to 6 detected components.

Specifications

Performance	
Rated Capacity	See table at the right.
Linearity	Within $\pm 0.5\%$ RO
Hysteresis	Within $\pm 0.5\%$ RO
Interference	$\pm 1.5\%$ RO (after correction by attached correction coefficient) • Output voltage of 6 component forces should be corrected by the interference correction coefficient since output of one component force affects output of other component forces.
Rated Output	Approx. ± 1500 mV (with no-load output at the center)
Environmental Capability	
Safe Temp. Range	-10 to 70°C (noncondensing)
Comp. Temp. Range	0 to 60°C (noncondensing)
Temp. Effect on Zero Bal.	Within $\pm 0.05\%$ RO/ $^\circ\text{C}$
Temp. Effect on Out.	Within $\pm 0.05\%$ / $^\circ\text{C}$

Dimensions

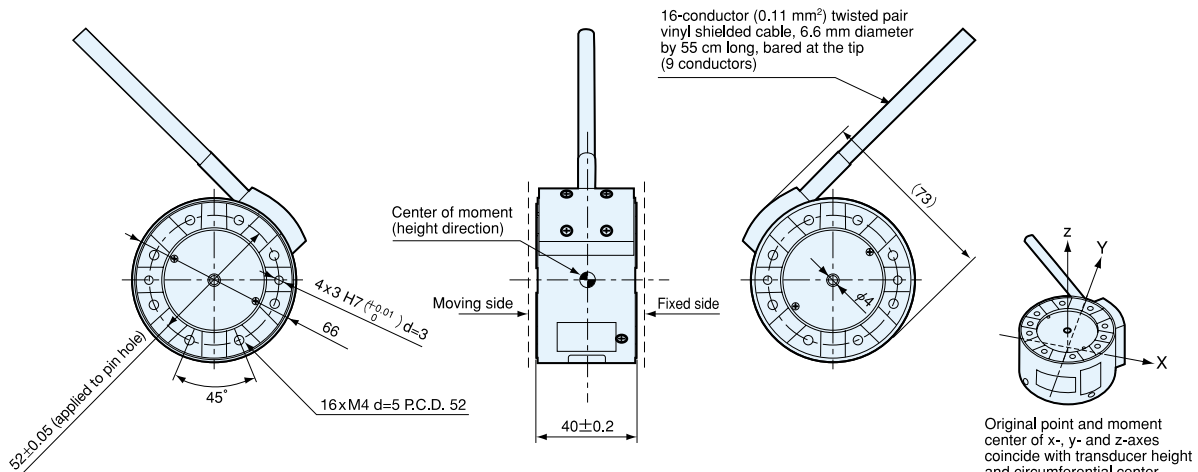

Electrical Characteristics

No-Load Output 2500 mV at the center (See figure below)

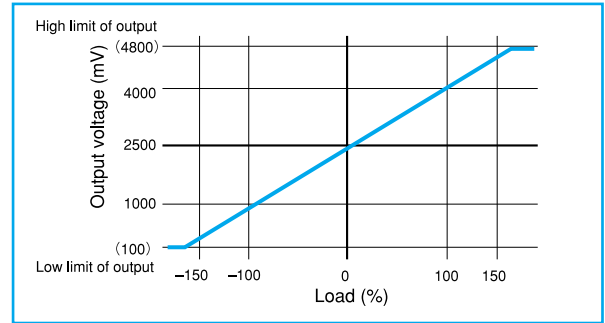

Frequency Response DC to 500 Hz (+1 dB to -3 dB)

Power Supply 5 V DC $\pm 10\%$, 160 mA

Cable 16-conductor (0.11 mm²) twisted pair vinyl shielded cable, 6.6 mm dia. by 55 cm long, bared at the tip (9 conductors only)

Mechanical Properties

Safe Overload Rating 150%

Enclosure Main unit (LFX-A-1KN): Aluminum (metallic finish)

Main unit (LFX-A-3KN): SUS (metallic finish)

Cover: Black anodic oxide coating aluminum

Cable holder: Anodic oxide coating aluminum

Weight See table below.

Protection Rating IP 40

- To obtain the rated output of ± 1500 mV for each of 6-component force, zero drift due to installation conditions including tightening and loading should be made within ± 200 mV.
- Interference compensator LIC-100A is optionally available for LFX-A.

Model	Rated Capacity	Weight (Approx.)
LFX-A-1KN	F_x : ± 1000 N F_y : ± 1000 N F_z : ± 1000 N M_x : ± 40 N·m M_y : ± 40 N·m M_z : ± 25 N·m	250 g
LFX-A-3KN	F_x : ± 3000 N F_y : ± 3000 N F_z : ± 3000 N M_x : ± 100 N·m M_y : ± 100 N·m M_z : ± 50 N·m	450 g

6-Component Force Measuring Systems

Interference Compensation through Calculation for Accurate Measurement

LAT-1000A Series

100 to 300 N



LAT-A



FDP-106A

Each system in the LAT-1000A series consists of the LAT-A 6-component force transducer and the FDP-106A signal processor. The LAT-A simultaneously detects 3 forces in 3 axial directions orthogonal to the transducer and 3 moments around the 3 axes. The FDP-106A automatically eliminates interference components contained in transducer output through calculation. By minimizing errors due to interference, the system enables highly accurate measurement of both single and multiple component force loads.

Features

- To guarantee measurement accuracy, performance with multiple component force loaded is indicated with a maximum error (see note in the next page).
- Highly accurate measurement possible even with multiple component force loaded
- Simultaneous sampling of 6-component force and processing signals up to approximately 300 Hz possible
- The compact, lightweight transducer is strain gage based and is cased with a highly rigid special aluminum alloy.
- Calibration coefficient is preset in the signal processor, enabling immediate measurement by connecting a monitor indicator.
- 5-V output available with the rated load
- Force and moment can be read directly on a PC if connected.
- Direct reading mode is provided to read force and moment at the load point.
- High/low limit and hysteresis width of the high/low limit are set to alarm output.

Configuration

- 6-component force transducer LAT-A
- Signal processor FDP-106A
- PC (not included)

General Specifications

Rated Capacity

Model	Rated Capacity					
	F_x N	F_y N	F_z N	M_x N·m	M_y N·m	M_z N·m
LAT-1010KA-1	100	100	200	10	10	10
LAT-1010KA-2	100	100	200	20	20	20
LAT-1020KA-1	200	200	200	10	10	10
LAT-1020KA-2	200	200	200	20	20	20
LAT-1030KA-1	300	300	300	10	10	10
LAT-1030KA-2	300	300	300	20	20	20

Safe Overload Rating 120%

Nonlinearity Within $\pm 0.5\%$ RO

Hysteresis Within $\pm 0.5\%$ RO

Interference $\pm 0.8\%$ RO

Maximum Error $\pm 1.5\%$ RO (LAT-KA-2: $\pm 3\%$ RO)

Resolution 0.05% FS

Temp. Effect on Zero Bal. Within $\pm 0.25\%$ RO/ $^{\circ}$ C

Temp. Effect on Out. Within $\pm 0.05\%$ / $^{\circ}$ C

Comp. Temp. Range 0 to 50 $^{\circ}$ C

Specifications stated above are values measured with our calibrators under incompany standard conditions.

Dimensions

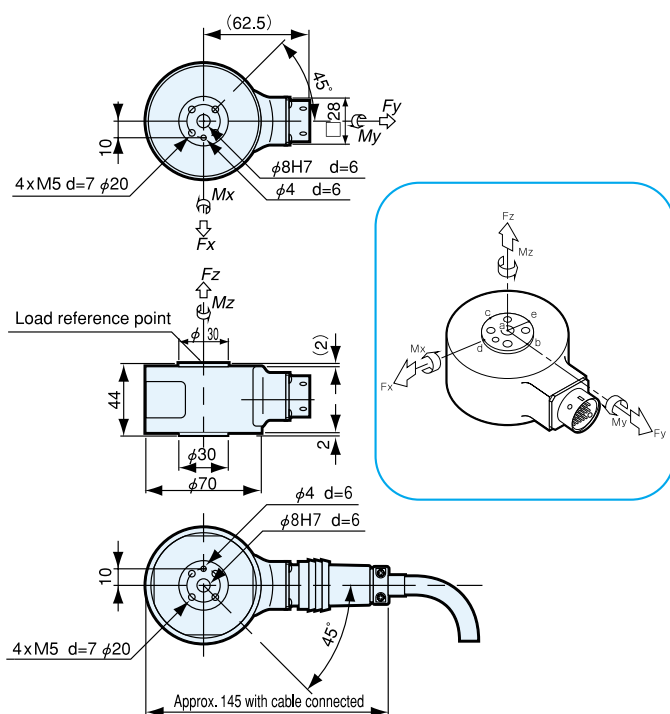

Arrow (\rightarrow) direction is plus output.

6-Component Force Transducer LAT-A Specifications

Rated Capacity	Fx, Fy: 100, 200, 300 N
	Fz: 200, 300 N
	Mx, My, Mz: 10, 20 N·m
	See table in the previous page for combinations.
Safe Overload Rating	120%
Natural Frequency (with all models)	Fx, Fy: Approx. 2.3 kHz, Fz: Approx. 5.5 kHz
	Mx, My: Approx. 8 kHz, Mz: Approx. 4 kHz
Recom. Excit. Voltage	2.5 V DC
Safe Excit. Voltage	5 V DC
Input Resistance	58.3 Ω ±10%
Output Resistance	350 Ω ±2%
Comp. Temp. Range	0 to 60°C
Safe Temp. Range	0 to 70°C
Temp. Effect on Zero Bal.	Within ±0.05% RO/°C
Temp. Effect on Out.	Within 0.05%/°C
Weight	Approx. 250 g (with all models)
Protection Rating	IP 40 (JIS C 0920)
Cable	14-conductor (0.3 mm ²) PVC shielded cable, 9 mm dia., with connector plug at both ends. N-78 for connection to FDP-106A For displacement and inclinaton angle, contact us.

Standard Accessories

Communications program (DOS/Windows version), torque wrench, hexagon socket wrench, parallel pins φ4 and φ8, connection cable N-78

Signal Processor FDP-106A Specifications

Input	Number of channels: Max. 6 (6-component force)
	Zero balance adjust.: Automatic (true electron method)
	Excitation voltage: 2.5 V DC
Analog Output	Number of channels: 6
	Output: ±5 V (150% the rated output of 6-component force transducer may be made ±5 V.)
	Resolution: 0.05% FS
	Frequency response range: DC to app. 300 Hz
	Initial setting: ±5 V analog output for the rated capacity of 6-component force transducer, 0 mm for coordinates X, Y and Z at the load point
Serial Interface	RS-232C
	Transmission mode: Start-stop synchronized mode
	Transmission rate: 9600 bps fixed
	Data: 8 bits
	Parity: None
	Stop bit: 1
	Transmission contents: Data, setting conditions
Data format: Binary or ASCII	
Connector: D-Sub 25 pin, female	
PC connection: Optional interface cable for RS-232C	
Sampling Frequency	When not using digital output
	0.72 ms/6 channels (cutoff frequency 366 Hz)
	When using digital output
22.9 ms/6 channels in binary format (cutoff frequency 11 Hz)	
45.7 ms/6 channels in ASCII format (cutoff frequency 6 Hz)	
Nonlinearity	Within ±0.05% FS
Calc. Error in Infr. Comp.	Within ±0.1% FS
Stability	Zero ±0.25 μV/V/°C, Sensitivity ±0.01%/°C
Functions	Overinput checking, automatic zero balance, load point correction, alarm
Monitor Indicator	LED
Alarm Output	Open collector
Oprg. Temp. Range	0 to 50°C, 95% RH or less (noncondensing)
Power Supply	100 V AC ±10% (200 V AC optionally available)
Dimensions & Weight	255 x 88 x 180 mm (excl. protrusions), app. 2.5 kg

Standard Accessories

Output cable U-58 (6 pcs.), AC power cable P-18 with conversion adapter CM-33

Options RS cross cable N-23, Mounting fixture FL-1A

Communications Program (Attached to LAT-A)

Windows Version	
Operating Environment	
OS	Windows 98/SE/Me/2000/XP
Memory	64 MB or more
Display	800 x 600 dots or more
DOS Version	
Compatible PC	PC-98 (excluding NX series) DOS/V, IBM-PC/AT (English version)
Functions (Commands)	Measurement: Execute auto zero balance and select output mode.
	Setting: Read/write alarm value and coordinate values at the load point
	Transducer: Read the model, serial number, rated capacity and unit number. Others: Test the RS communications line, inquire the product name, reset, etc.
Sample Program	Enables setting, measurement, data recording and display of acquired data, with QuickBasic source. Executable also with Visual Basic.
Media	3.5" floppy disk 2DD MS-DOS format (with Windows, the program is usable only from DOS prompt)

Note on Maximum Error

Definition

A maximum error denotes a maximum deviation in plus and minus directions from the characteristic curve observed when testing devices or equipment according to stipulated procedures under standard operating conditions.

Description

Performance specifications of a load cell include non-linearity, hysteresis and repeatability. In the case of a 6-component force transducer, interference is added to these performance specifications. All these specifications apply to a single component force, that is, force or moment in a single direction. However, the 6-component force transducer rarely receives a single component force and detects 2 or more component force. Accordingly, characteristic values for multiple component force should be considered. To solve the problem, a maximum error is newly included in performance specifications of the LAT-A series. The maximum error is obtained as follows:

Apply an external force F_M of known value to the 6-component force transducer and read resultant output values of F_x , F_y , F_z , M_x , M_y and M_z . Referring to the magnitude and direction of the external force F_M , calculate 6-component force F_{xM} , F_{yM} , F_{zM} , M_{xM} , M_{yM} and M_{zM} .

A maximum error of F_x is calculated using the following equation:

Maximum error of $F_x = (F_x - F_{xM})/F_{x0} \times 100$ (% RO)
where, F_{x0} is the rated capacity for the force in X direction.

Maximum errors of other components are calculated in the same manner.

Practically, we tested through simultaneous application of 3-component force in 3 directions and 6-component force/moment in 3 directions and confirmed that the calculated maximum errors satisfy the stated specification.

Thus, the LAT-A series 6-component force transducers are assured of the accuracy in measurement of multiple component force loads, enabling safe operation under any loading conditions.

3-Component Force Transducers

For Special Purposes, Especially Suitable for Model Experiments

LSM-B-SA1

10 to 500 N

Compact and Lightweight

Easy-to-Handle

Simultaneous Measurement of F_x , F_y and F_z



Enables force measurement in X, Y and Z directions. The compact, lightweight strain gage-based design is suitable for model experiments. (Patented)

Specifications

Performance	
Rated Capacity	See table below.
Nonlinearity	Within $\pm 0.5\%$ RO
Hysteresis	Within $\pm 0.5\%$ RO
Rated Output	Approx. ± 0.5 mV/V (1000 μ m/m)
Environmental Capability	
Safe Temp. Range	0 to 80°C
Comp. Temp. Range	0 to 70°C
Temp. Effect on Zero Bal.	Within $\pm 0.05\%$ RO/°C
Temp. Effect on Out.	Within $\pm 0.05\%$ /°C
Electrical Characteristics	
Safe Excit. Voltage	10 V AC or DC
Recom. Excit. Voltage	1 to 5 V AC or DC
Input Resistance	240 Ω $\pm 5\%$
Output Resistance	240 Ω $\pm 5\%$
Cable	4-conductor (0.08 mm ²) chloroprene shielded cable, 4 mm dia. by 5 m long, with connector plug to transducer and bared to amplifier (Shield wire is not connected to the mainframe.)
Mechanical Properties	
Safe Overload Rating	150%
Natural Frequency	See table below.
Weight	See table below.
Protection Rating	IP 20
Interference	$\pm 3\%$ RO
Safe Moment	See table below.

Dimensions

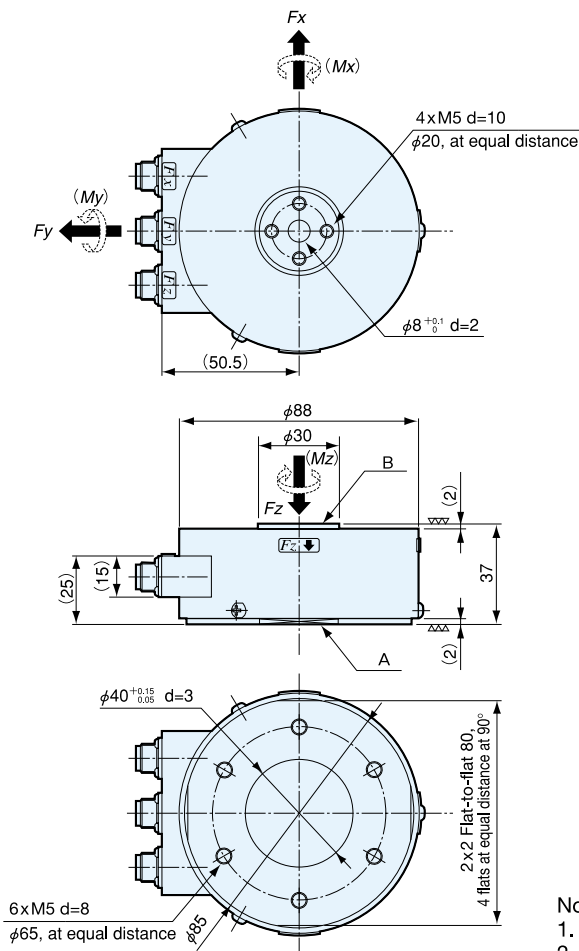

Note: For the cable terminated with NDIS connector, suffix "-P" to the model number.

To Ensure Safe Usage

LSM-B-SA1 series does not feature waterproof structure.

Notes:

- M_x , M_y and M_z cannot be measured.
- Arrows indicate directions of component force in plus polarity acting to the B plane with the A plane fixed.

Model	Rated Capacity			Natural Frequency (App.)			Safe Moment (App.)			Weight (App.)
	F_x	F_y	F_z	X	Y	Z	M_x	M_y	M_z	
LSM-B-10NSA1	10 N			0.3 kHz	0.2 kHz	1.2 N·m (0.12 kgf·m)			600 g	
LSM-B-20NSA1	20 N			0.4 kHz	0.3 kHz	2.4 N·m (0.24 kgf·m)				
LSM-B-50NSA1	50 N			0.8 kHz	0.6 kHz	5.9 N·m (0.60 kgf·m)				
LSM-B-100NSA1	100 N			1.3 kHz	0.9 kHz	9.8 N·m (1.0 kgf·m)				
LSM-B-200NSA1	200 N			2.5 kHz	2.0 kHz	24 N·m (2.4 kgf·m)				
LSM-B-500NSA1	500 N			2.2 kHz	1.8 kHz	59 N·m (6.0 kgf·m)			1.6 kg	

Safe moment is stated for reference to strength.

Jack Load Cells

For Measurement of Loads Applied to Jacks

LUR-B-SA1

10 kN to 5 MN

Special Design for Jacks

Low Price

Various Capacity Ranges



LUR-B-SA1 series load cells are designed to measure loads applied to jacks when lifting up or moving a large machinery or structure in civil engineering and construction fields, etc. Placed in between, these load cells enable the operators to prevent overloads, unbalanced loads or movement of the center of gravity.

Specifications

Performance	
Rated Capacity	See table below.
Nonlinearity	Within $\pm 0.2\%$ RO (300KNSA1 to 5MNSA1: Within $\pm 0.5\%$ RO)
Hysteresis	Within $\pm 0.1\%$ RO (300KNSA1 to 5MNSA1: Within $\pm 0.5\%$ RO)
Rated Output	± 1 mV/V (± 2000 μ m/m) $\pm 1\%$
Environmental Capability	
Safe Temp. Range	-10 to 60°C
Comp. Temp. Range	0 to 60°C
Temp. Effect on Zero Bal.	Within $\pm 0.01\%$ RO/ $^\circ\text{C}$
Temp. Effect on Out.	Within $\pm 0.01\%$ / $^\circ\text{C}$
Electrical Characteristics	
Safe Excit. Voltage	15 V AC or DC
Recom. Excit. Voltage	1 to 12 V AC or DC
Input Resistance	350 Ω $\pm 2\%$
Output Resistance	350 Ω $\pm 2\%$
Cable	4-conductor (0.3 mm ²) chloroprene shielded cable, 7.6 mm dia. by 10 m long, terminated with NDIS connector plug
Mechanical Properties	
Safe Overload Rating	200%
Weight	See table below.

With the capacity of 200 kN or more, calibration is performed or compression load only.

Dimensions

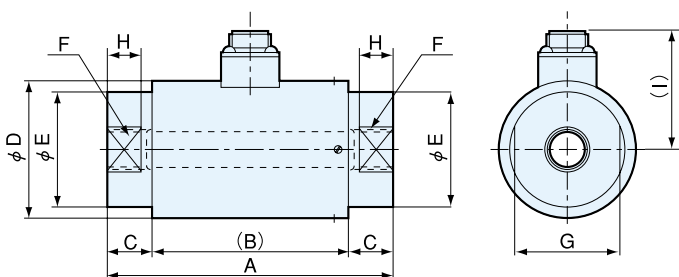

Model	Rated Capacity	A	B	C	ϕ D	ϕ E	F	G	H	I	Weight (App.)
LUR-B-10KNSA1	± 10 kN	100	70	15	55	25	M12 P=1.75 d=15	20	10	50	1.4 kg
LUR-B-20KNSA1	± 20 kN	110	70	20	60	50	M18 P=1.5 d=20	46	15	53	2.1 kg
LUR-B-30KNSA1	± 30 kN	125	85	20	60	50	M24 P=2 d=30	46	15	53	2.2 kg
LUR-B-50KNSA1	± 50 kN										
LUR-B-100KNSA1	± 100 kN	175	105	35	65	55	M39 P=2 d=45	50	25	55	2.5 kg
LUR-B-200KNSA1	± 200 kN	255	125	65	80	70	M50 P=2 d=65	65	40	63	5.2 kg
LUR-B-300KNSA1	± 300 kN	255	125	65	100	90	M65 P=3 d=65	—	—	74	8 kg
LUR-B-500KNSA1	± 500 kN	330	170	80	130	120	M85 P=3 d=85	—	—	89	15 kg
LUR-B-1MNSA1	± 1 MN	430	210	110	188	158	M110 P=3 d=118	—	—	119	55 kg
LUR-B-1.5MNSA1	± 1.5 MN	530	250	140	220	200	M140 P=4 d=140	—	—	135	85 kg
LUR-B-2MNSA1	± 2 MN	590	270	160	260	228	M160 P=4 d=170	—	—	155	100 kg
LUR-B-3MNSA1	± 3 MN	700	360	170	300	270	M190 P=4 d=190	—	—	175	170 kg
LUR-B-5MNSA1	± 5 MN	900	450	225	370	350	M240 P=6 d=250	—	—	210	300 kg

LTA-B-S/C-S

20 to 500 kN

Built-in Amplifier and Voltage Output (B-S)

Noise Resistant (B-S)

High Strength

Easy-to-Handle

High Reliability

High Stability



These series of tension load cells can be used as detectors for jib crane weighing systems and for general tension measurement. LTA-B-S series is equipped with an amplifier and provide voltage output of 1 to 5 V.

LTA-C-S Specifications

Performance	
Rated Capacity	See table at the left.
Nonlinearity	Within $\pm 1\%$ RO
Hysteresis	Within $\pm 1\%$ RO
Rated Output	0.6 to 0.7 mV/V (1200 to 1400 $\mu\text{m/m}$)
Environmental Capability	
Safe Temp. Range	-20 to 70°C
Comp. Temp. Range	-10 to 60°C
Temp. Effect on Zero Bal.	Within $\pm 0.05\%$ RO/°C
Temp. Effect on Out.	Within $\pm 0.05\%$ /°C
Electrical Characteristics	
Safe Excit. Voltage	12 V AC or DC
Recom. Excit. Voltage	1 to 10 V AC or DC
Input Resistance	350 $\Omega \pm 5\%$
Output Resistance	350 $\Omega \pm 5\%$
Cable	4-conductor (0.75 mm ²) chloroprene shielded cable, 10 mm dia. by 10 m long, with press-fit terminal (Shield wire is not connected to the mainframe.)
Mechanical Properties	
Breaking Overload Rating	Approx. 500%
Safe Overload Rating	150%
Weight	See table at the left.
Protection Rating	IP 64 (Sprashproof type conforming to JIS C 0920)

Dimensions

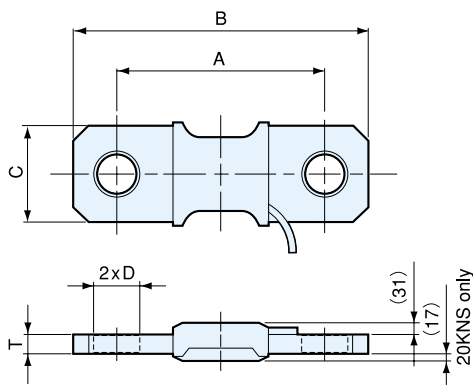

Model	Rated Capacity	A	B	C	D	T	Weight (Approx.)
LTA-B-20KNS LTA-C-20KNS	20 kN	310	410	90	$\phi 45$	14	5 kg
LTA-B-50KNS LTA-C-50KNS	50 kN	310	430	110	$\phi 45$	15	5.5 kg
LTA-B-100KNS LTA-C-100KNS	100 kN	330	470	126	$\phi 60$	30	11 kg
LTA-B-200KNS LTA-C-200KNS	200 kN	360	540	170	$\phi 65$	36	21 kg
LTA-B-300KNS LTA-C-300KNS	300 kN	400	610	195	$\phi 75$	47	35 kg
LTA-B-500KNS LTA-C-500KNS	500 kN	440	670	240	$\phi 85$	60	60 kg

Amplifier-Equipped LTA-B-S Specifications

Performance	
Rated Capacity	See table at the left.
Nonlinearity	Within $\pm 1\%$ RO
Hysteresis	Within $\pm 1\%$ RO
Rated Output	Under no load: 1 V ± 0.015 V, When loaded: 5 V ± 0.040 V
Environmental Capability	
Safe Temp. Range	-20 to 70°C
Comp. Temp. Range	-10 to 60°C
Temp. Effect on Zero Bal.	Within $\pm 0.1\%$ RO/°C
Temp. Effect on Out.	Within $\pm 0.08\%$ /°C
Electrical Characteristics	
Built-in Amplifier	Provided
Operating Voltage	10 V DC ± 1 V
Load Resistance	5 k Ω or more
Cable	4-conductor (0.75 mm ²) chloroprene shielded cable, 10 mm dia. by 10 m long, with press-fit terminal (Shield wire is not connected to the mainframe.)
Mechanical Properties	
Breaking Overload Rating	Approx. 500%
Safe Overload Rating	150%
Weight	See table at the left.
Protection Rating	IP 64 (Sprashproof type conforming to JIS C 0920)

To Ensure Safe Usage

- Install the load cell carefully so that tensile or impact force may not applied to the cable to prevent the load cell from receiving bending or twisting force.
- Prepare a safety device such as link against accidental hazards so that it supports loads in place of a broken load cell.

One-End Revolving Tension Load Cells

For Measurement of Drawbar Pull and Rope Tension

LTR-S-SA1

20 to 50 kN



LTR-S-SA1 series load cells are suitable for measurement of tensile force of rope. Since the hook at one end revolves together with the rope which may revolve due to twisting, easy installation and handling are ensured.

Specifications

Performance	
Rated Capacity	See table below.
Nonlinearity	Within $\pm 0.5\%$ RO
Hysteresis	Within $\pm 0.5\%$ RO
Rated Output	Approx. 1 mV/V (2000 $\mu\text{m/m}$)
Environmental Capability	
Safe Temp. Range	-20 to 70°C
Comp. Temp. Range	-10 to 60°C
Temp. Effect on Zero Bal.	Within $\pm 0.05\%$ RO/ $^\circ\text{C}$
Temp. Effect on Out.	Within $\pm 0.05\%$ / $^\circ\text{C}$
Electrical Characteristics	
Safe Excit. Voltage	12 V AC or DC
Recom. Excit. Voltage	1 to 5 V AC or DC
Input Resistance	$350 \Omega \pm 2\%$
Output Resistance	$350 \Omega \pm 2\%$
Cable	4-conductor (0.3 mm ²) chloroprene shielded cable, 7.6 mm dia. by 5 m long, terminated with NDIS connector plug (Shield wire is not connected to the mainframe.)
Mechanical Properties	
Safe Overload Rating	150%
Stat. Brkg. Orld. Rtg.	200% (50KNSA1: 150%)
Weight	Approx. 3.6 kg
Protection Rating	IP 23

To Ensure Safe Usage

- When loaded, sliding friction prevents the revolving part from revolving.
- Do not use for measurement of hanging load.

Dimensions

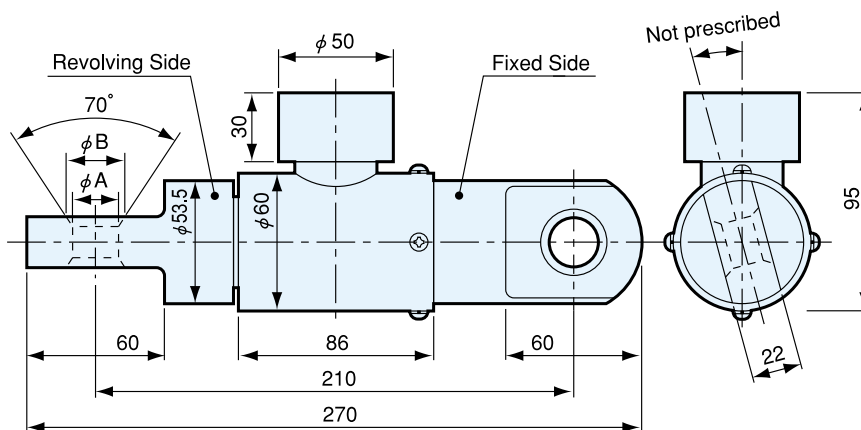

Model	Rated Capacity	ϕA	ϕB
LTR-S-20KNSA1	20 kN	20	26
LTR-S-30KNSA1	30 kN		
LTR-S-50KNSA1	50 kN	22	29

Pin-Type Load Cells

Designed for Pulley Axis

LTP-S-S

10 to 500 kN

Specially Designed for Installation to Pin Connection

Compact, Space-Saving Design

Can be Manufactured to Meet the Size of Existing Pin

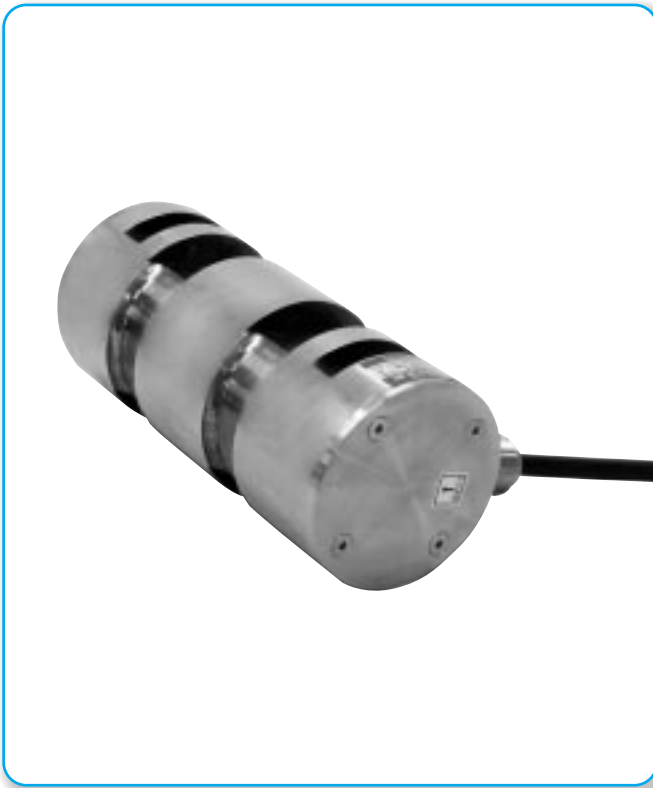

Mounted in place of the axis of crane's pulley, LTP-S-S series pin-type load cells enable measurement of hanging loads. Such the feature ensures easy installation and handling. Since strain gages are used as the load detector, each load cell in this series is compact, lightweight and economically priced.

Specifications

Performance	
Rated Capacity	See table below.
Nonlinearity	± 1 to 2% RO (depends on user's spec.)
Hysteresis	± 1 to 2% RO (depends on user's spec.)
Rated Output	0.5 to 1 mV/V (1000 to 2000 $\mu\text{m/m}$)
Environmental Capability	
Safe Temp. Range	-20 to 80°C
Comp. Temp. Range	-10 to 70°C
Temp. Effect on Zero Bal.	Within $\pm 0.05\%$ RO/°C
Temp. Effect on Out.	Within $\pm 0.05\%$ /°C
Electrical Characteristics	
Safe Excit. Voltage	15 V AC or DC
Recom. Excit. Voltage	1 to 10 V AC or DC
Input Resistance	700 Ω $\pm 3\%$
Output Resistance	700 Ω $\pm 3\%$
Cable	4-conductor chloroprene shielded cable (length is as required)
Mechanical Properties	
Safe Overload Rating	150%
Protection Rating	IP 64 (Sprashproof type conforming to JIS C 0920)

Dimensions

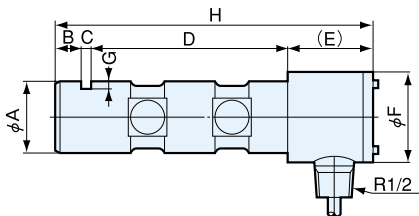

LTP-S-10 to 50KNS

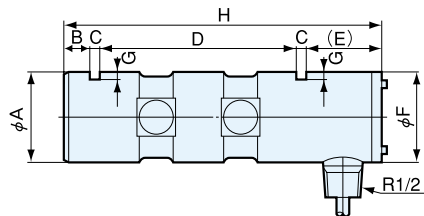

LTP-S-100 to 500KNS

Installation Example

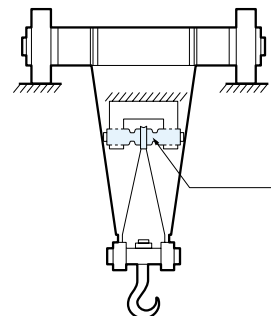

Model	Rated Capacity	ϕA	B	C	D	E	ϕF	G	H
LTP-S-10KNS	10 kN	40	15	5	112	40	50	4	172
LTP-S-20KNS	20 kN								
LTP-S-50KNS	50 kN	50	15	7	140	40	55	6	202
LTP-S-100KNS	100 kN	60	20	8	168	40	60	8	244
LTP-S-200KNS	200 kN	70	20	10	212	40	70	8	292
LTP-S-500KNS	500 kN	95	22	12	262	45	95	10	341

Dimensions above are reference values and can be changed to user's specifications.

Rectangular Load Cells

For Measurement of Loads to Pillow Block

LCD-A-S1 to S9

30 to 100 kN

Flat load-receiving part

Hermetically-Sealed Structure

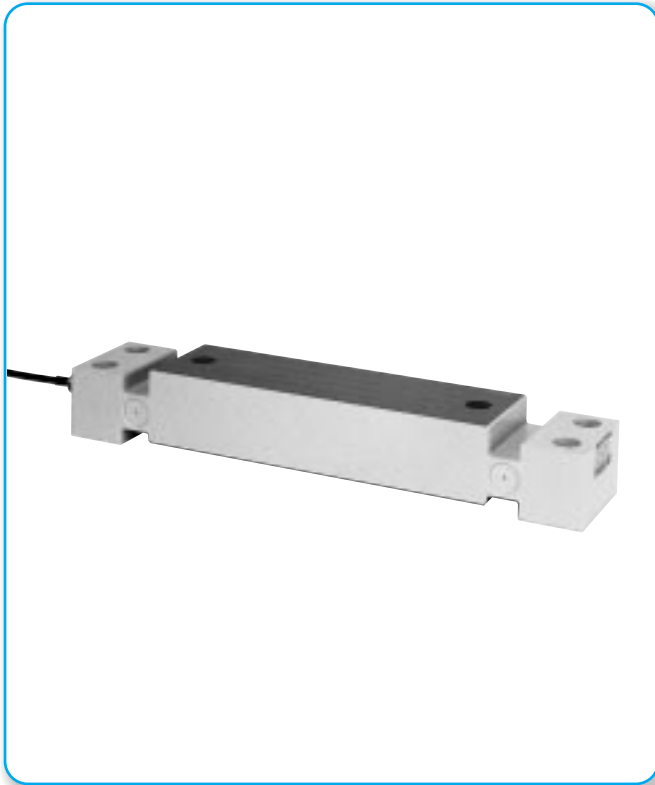

Having the flat top and bottom, LDC-A-S series rectangular compression load cells enable stable installation of a flat board to the top. Can be used for weighing systems of waste and ash cranes or for measurement of compression loads to pillow blocks placed on them.

Specifications

Performance	
Rated Capacity	See table below.
Nonlinearity	Within $\pm 1\%$ RO
Hysteresis	Within $\pm 1\%$ RO
Rated Output	1 mV/V (2000 $\mu\text{m}/\text{m}$) or more
Environmental Capability	
Safe Temp. Range	-20 to 80°C
Comp. Temp. Range	-10 to 70°C
Temp. Effect on Zero Bal.	Within $\pm 0.01\%$ RO/ $^\circ\text{C}$
Temp. Effect on Out.	Within $\pm 0.01\%$ / $^\circ\text{C}$
Electrical Characteristics	
Safe Excit. Voltage	15 V AC or DC
Recom. Excit. Voltage	1 to 10 V AC or DC
Input Resistance	$350 \Omega \pm 5\%$
Output Resistance	$350 \Omega \pm 5\%$
Cable	4-conductor (0.75mm ²) fluoroles shielded cable, 8 mm dia. by 10 m long, bared at the tip (Shield wire is not connected to mainframe.)
Mechanical Properties	
Safe Overload Rating	150%
Weight	See table below.
Protection Rating	IP 64 (Sprashproof type conforming to JIS C 0920)

Dimensions

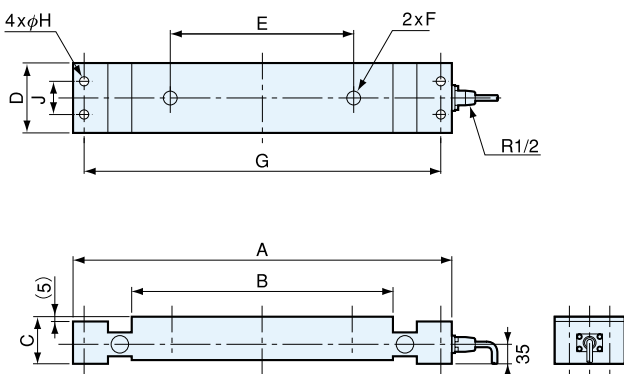

To Ensure Safe Usage

Take care that there is no foreign matter on the top and bottom of the load cell and the surface of mounting board.

Model	Rated Capacity	A	B	C	D	E	F	G	H	J	Weight (App.)
LCD-A-30KNS1	30 kN	520	340	70	95	280	M22 d=30	484	14	50	22 kg
LCD-A-30KNS2		580	400	70	105	280	M22 d=30	544	14	50	28 kg
LCD-A-30KNS3		580	400	70	105	330	M27 d=35	544	14	50	28 kg
LCD-A-50KNS4	50 kN	610	430	80	105	280	M22 d=30	574	14	50	35 kg
LCD-A-50KNS5		580	400	80	105	330	M27 d=35	540	26	60	33 kg
LCD-A-50KNS6		610	430	80	105	360	M27 d=35	550	26	60	35 kg
LCD-A-50KNS7		690	510	80	105	410	M30 d=35	626	26	50	40 kg
LCD-A-100KNS8	100 kN	690	510	80	105	410	M30 d=35	626	26	50	40 kg
LCD-A-100KNS9		690	510	80	105	430	M30 d=35	626	26	50	40 kg

Dimensions above are reference values and can be changed to user's specifications.

Rectangular Load Cells

For Steelmaking Line

LCD-B-S

5 to 20 kN

Safe Overload Rating of 400% and Mechanical Overload Rating of 500%

Protection Rating IP64

Stainless Steel

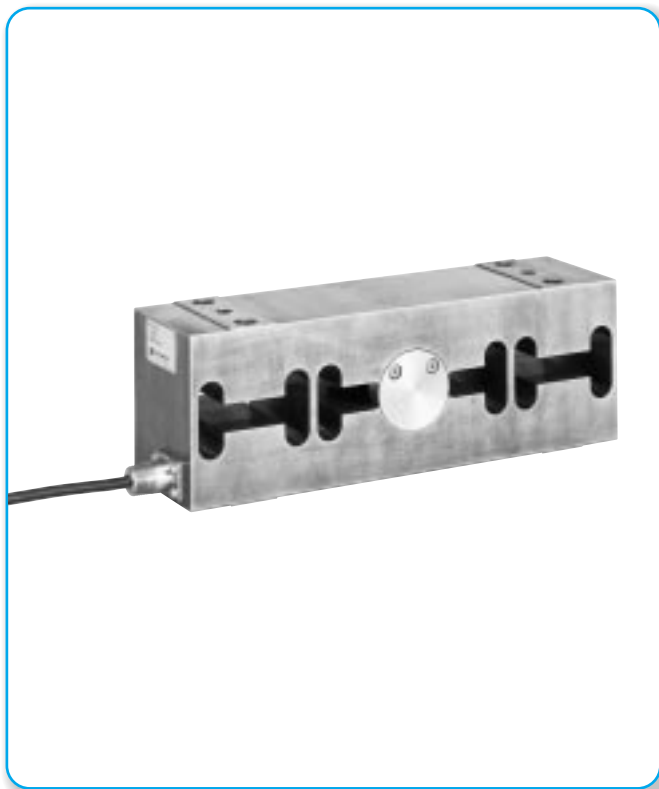

While designed for monitoring and control of steel rolling process, LCD-B-S series load cells can be manufactured for other processes. Inquiries are welcome.

Specifications

Performance		
Rated Capacity	Model	Rated Capacity
	LCD-B-5KNS	5 kN
	LCD-B-10KNS	10 kN
	LCD-B-20KNS	20 kN
Nonlinearity	Within $\pm 0.2\%$ RO	
Hysteresis	Within $\pm 0.1\%$ RO	
Repeatability	$\pm 0.1\%$ RO or less	
Rated Output	0.8 mV/V (1600 $\mu\text{m/m}$) or more	
Environmental Capability		
Safe Temp. Range	-20 to 120°C	
Comp. Temp. Range	-10 to 100°C	
Temp. Effect on Zero Bal.	Within $\pm 0.01\%$ RO/°C	
Temp. Effect on Out.	Within $\pm 0.01\%$ °C	
Electrical Characteristics		
Safe Excit. Voltage	15 V AC or DC	
Recom. Excit. Voltage	1 to 10 V AC or DC	
Input Resistance	350 $\Omega \pm 2\%$	
Output Resistance	350 $\Omega \pm 2\%$	
Cable	4-conductor (0.75 mm ²) fluonlex shielded cable, 8 mm dia. by 20 m long, bared at the tip	
Mechanical Properties		
Mech. Ord. Rating	500%	
Safe Overload Rating	400%	
Weight	Approx. 30 kg	
Protection Rating	IP 64 (Sprashproof type conforming to JIS C 0920)	
Enclosure	Stainless steel (metallic finish)	

Models with higher rated capacities than above are available.

Dimensions

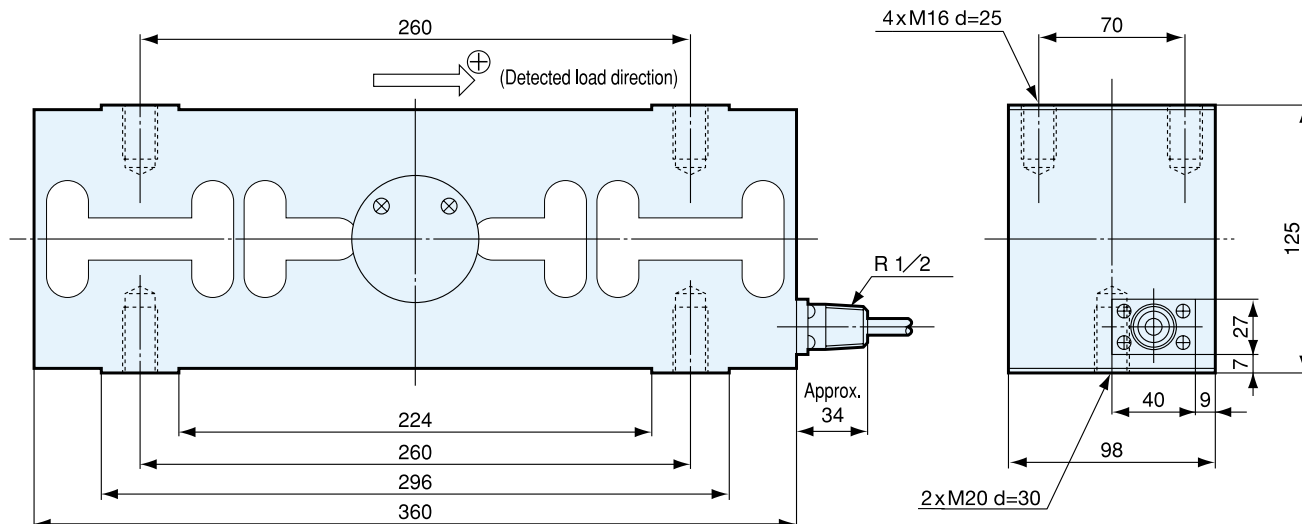

Rectangular Load Cells

For Steelmaking Line

LCD-C-S

50 to 100 kN

Safe Overload Rating of 400%

Mechanical Overload Rating of 500%

Corrosion Resistant

Highly Reliable Structure (IP64)

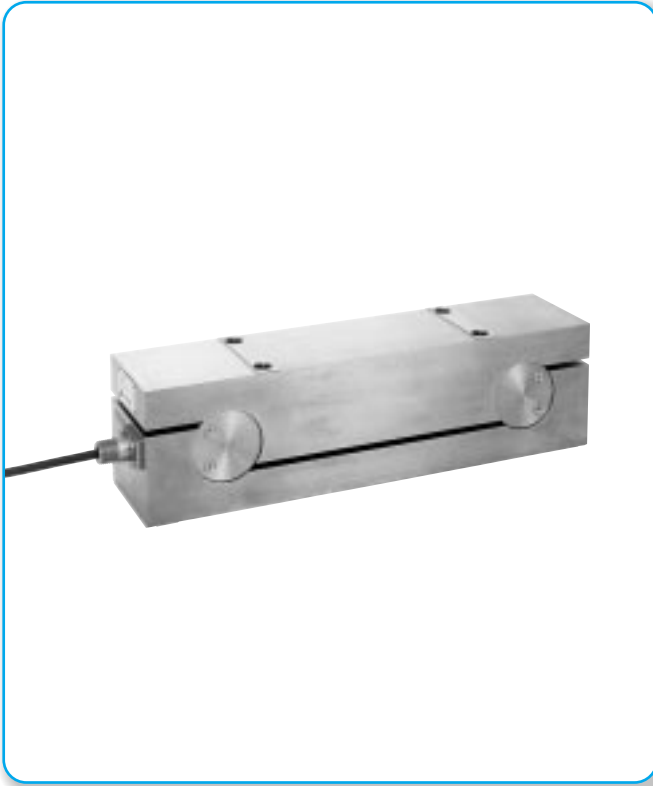

While designed for monitoring and control of steel rolling process, LCD-C-S series load cells can be manufactured for other processes. Inquiries are welcome.

Specifications

Performance	
Rated Capacity	See table below.
Nonlinearity	Within $\pm 0.2\%$ RO
Hysteresis	Within $\pm 0.1\%$ RO
Repeatability	$\pm 0.1\%$ RO or less
Rated Output	0.8 mV/V (1600 $\mu\text{m/m}$) or more
Environmental Capability	
Safe Temp. Range	-20 to 120°C
Comp. Temp. Range	-10 to 100°C
Temp. Effect on Zero Bal.	Within $\pm 0.01\%$ RO/°C
Temp. Effect on Out.	Within $\pm 0.01\%$ /°C
Electrical Characteristics	
Safe Excit. Voltage	15 V AC or DC
Recom. Excit. Voltage	1 to 10 V AC or DC
Input Resistance	700 $\Omega \pm 2\%$
Output Resistance	700 $\Omega \pm 2\%$
Cable	4-conductor (0.75 mm ²) fluonlex shielded cable, 8 mm dia. by 20 m long, bared at the tip
Mechanical Properties	
Mech. Orld. Rating	500%
Safe Overload Rating	400%
Weight	Approx. 40 kg
Protection Rating	IP 64 (Sprashproof type conforming to JIS C 0920)
Enclosure	Stainless steel (metallic finish)

Dimensions

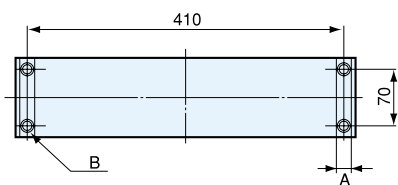
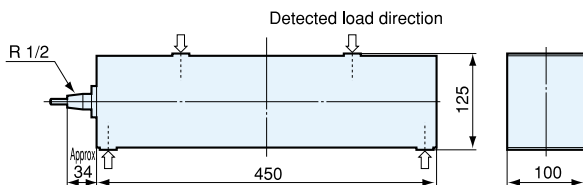
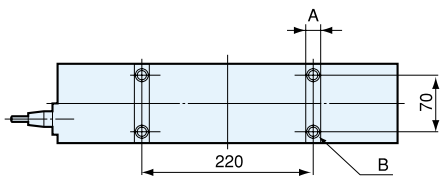

* If the load cell is expected to receive lateral loads, consult with our sales engineer.

- Models which can measure both tension and compression loads can be manufactured.
- Also available are small-sized models, 360 or 230 mm long, with smaller capacities than stated above and models with higher capacities.

Model	Rated Capacity	A	B
LCD-C-30KNS	30 kN	20	4-M16 d=25
LCD-C-50KNS	50 kN	20	
LCD-C-70KNS	70 kN	20	
LCD-C-100KNS	100 kN	30	4-M20 d=25

Rectangular Load Cells

For Steelmaking Line

LCD-D-S

500 kN to 5 MN

Safe Overload Rating of 200%

Highly Reliable Structure (IP64)



While designed for monitoring and control of steel rolling process, LCD-D-S series load cells can be manufactured for other processes. Inquiries are welcome.

Specifications

Performance	
Rated Capacity	See table below.
Nonlinearity	Within $\pm 1\%$ RO
Hysteresis	Within $\pm 1\%$ RO
Repeatability	$\pm 0.5\%$ RO or less
Rated Output	0.8 mV/V (1600 $\mu\text{m/m}$) or more
Environmental Capability	
Safe Temp. Range	-20 to 100°C
Comp. Temp. Range	-10 to 80°C
Temp. Effect on Zero Bal.	Within $\pm 0.01\%$ RO/°C
Temp. Effect on Out.	Within $\pm 0.01\%$ /°C
Electrical Characteristics	
Safe Excit. Voltage	15 V AC or DC
Recom. Excit. Voltage	1 to 10 V AC or DC
Input Resistance	350 $\Omega \pm 2\%$
Output Resistance	350 $\Omega \pm 2\%$
Cable	4-conductor (0.75 mm ²) fluorlex shielded cable, 8 mm dia. by 20 m long, bared at the tip
Mechanical Properties	
Mech. Orld. Rating	400%
Safe Overload Rating	200%
Weight	See table below.
Protection Rating	IP 64 (Sprashproof type conforming to JIS C 0920)
Enclosure	Stainless steel (metallic finish)

Dimensions

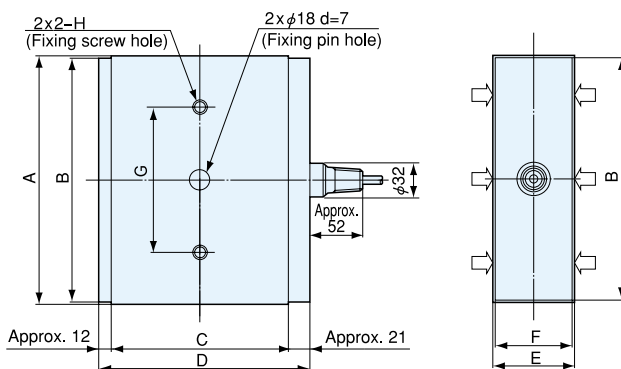

Illustrated appearance differs from photo above.

Model	Rated Capacity	A	B	C	D	E	F	G	H	Weight (App.)
LCD-D-500KNS	500 kN	140	136	117	150	60	56	80	M10 d=12	7 kg
LCD-D-1MNS	1 MN									
LCD-D-1500KNS	1.5 MN	210	206	117	150	60	56	100	M10 d=15	11 kg
LCD-D-2MNS	2 MN									
LCD-D-3MNS	3 MN									
LCD-D-3500KNS	3.5 MN	240	236	170	203	74	70	140	M10 d=15	23 kg
LCD-D-5MNS	5 MN	290	286	190	223	74	70	140	M10 d=15	30 kg

Tension Meter Load Cells

Excellent Environmental Resistance

LCR-B-S7

5 to 200 kN

High Safe Overload Rating of 300% Max.

Mechanical Stopper Activating against Overloads of 150 to 200%

Hermetically-Sealed Structure with Inert Gas Filled in

Highly reliable structure (IP64)

Corrosion resistant

Cable Direction Selectable from Either Left or Right



Designed for tension meters, LCR-B-S7 series load cells are suitable for load measurement under environments where heat resistance, oil resistance, corrosion resistance and high overload rating are required.

Specifications

Performance	
Rated Capacity	See table below.
Nonlinearity	Within $\pm 0.1\%$ RO (100, 200KNS7: Within $\pm 0.2\%$ RO)
Hysteresis	Within $\pm 0.1\%$ RO (100, 200KNS7: Within $\pm 0.2\%$ RO)
Repeatability	$\pm 0.1\%$ RO or less
Rated Output	1 mV/V (2000 $\mu\text{m/m}$) $\pm 1\%$
Environmental Capability	
Safe Temp. Range	-20 to 120°C
Comp. Temp. Range	-10 to 100°C
Temp. Effect on Zero Bal.	Within $\pm 0.005\%$ RO/ $^\circ\text{C}$
Temp. Effect on Out.	Within $\pm 0.005\%$ / $^\circ\text{C}$
Electrical Characteristics	
Safe Excit. Voltage	15 V AC or DC
Recom. Excit. Voltage	1 to 10 V AC or DC
Input Resistance	$350 \Omega \pm 1\%$
Output Resistance	$350 \Omega \pm 1\%$
Cable	4-conductor (0.75 mm ²) fluonlex shielded cable, 8 mm dia. by 10 m long, bared at the tip (Shield wire is not connected to mainframe.)

Dimensions

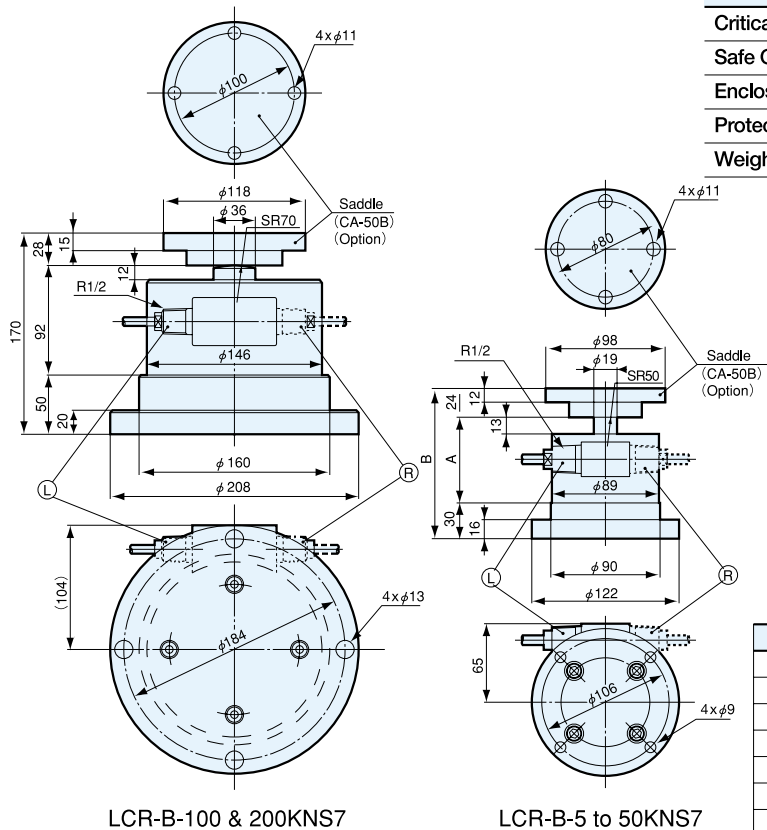

LCR-B-100 & 200KNS7

LCR-B-5 to 50KNS7

• The saddle is not included.

Mechanical Properties

Critical Ord. Rating	1000% (100, 200KNS7: 400%)
Safe Overload Rating	300% (100, 200KNS7: 200%)
Enclosure	Stainless steel (excluding the mount base of 100, 200KNS7)
Protection Rating	IP 64 (Sprashproof type conforming to JIS C 0920)
Weight	See table below.

To Ensure Safe Usage

Never disassemble the mount base, which has the stopper mechanism activating against overloads of 150 to 200%. Once removed, overload protection is not guaranteed.

Model	Rated Capacity	A	B	Weight (App.)
LCR-B-5KNS7 L/R	5 kN	57	111	4 kg
LCR-B-10KNS7 L/R	10 kN			
LCR-B-20KNS7 L/R	20 kN	70	124	4.5 kg
LCR-B-30KNS7 L/R	30 kN			
LCR-B-50KNS7 L/R	50 kN			
LCR-B-100KNS7 L/R	100 kN	See dimensional drawing at the left.		19 kg
LCR-B-200KNS7 L/R	200 kN			

Suffixes L and R indicate cable directions, left and right. Specify when ordering.

Customized Load Cells

We design and manufacture experimental and industrial load cells customized for applications and required accuracies. Please submit your desired requirements including application purpose, mounting method, rated capacity and operating environment.

● Economical Beam Type



Specifications

Performance	
Rated Capacity	2 N to 1 kN
Nonlinearity	Within $\pm 0.05\%$ RO
Hysteresis	Within $\pm 0.05\%$ RO
Rated Output	1 mV/V (2000 $\mu\text{m/m}$) $\pm 10\%$ (2 N to 30 N) 2 mV/V (4000 $\mu\text{m/m}$) $\pm 10\%$ (60 N to 1 kN)
Environmental Capability	
Temp. Effect on Zero Bal.	Within $\pm 0.06\%$ RO/ $^{\circ}\text{C}$ (2 N to 30 N) Within $\pm 0.03\%$ RO/ $^{\circ}\text{C}$ (60 N to 1 kN)
Temp. Effect on Out.	Within $\pm 0.01\%$ / $^{\circ}\text{C}$
Electrical Characteristics	
Safe Excit. Voltage	15 V AC or DC (2 N to 30 N) 20 V AC or DC (60 N to 1 kN)
Recom. Excit. Voltage	1 to 10 V AC or DC (2 N to 30 N) 1 to 12 V AC or DC (60 N to 1 kN)

Dimensions

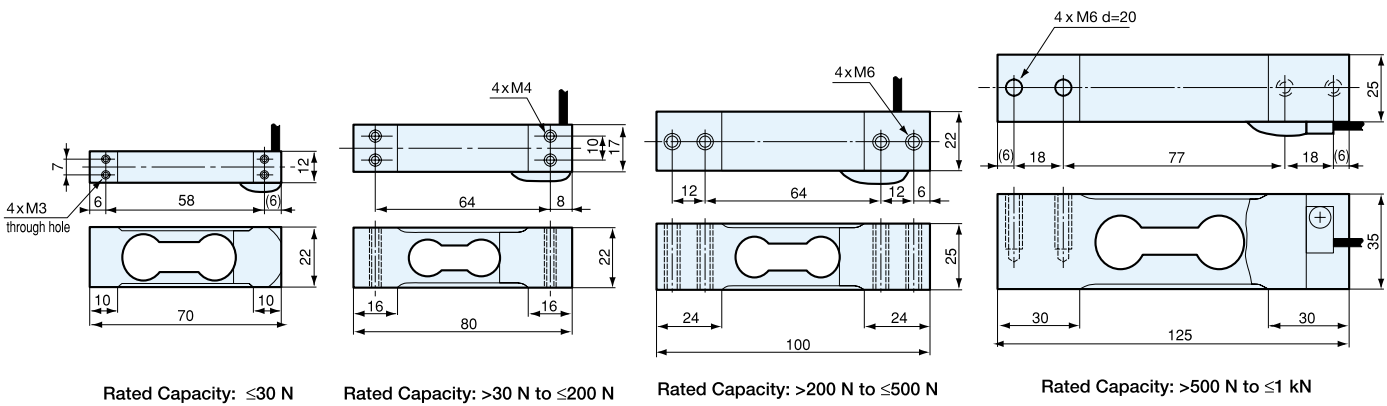

● Beam Type with Stopper



Specifications

Performance	
Rated Capacity	45 N
Nonlinearity	Within $\pm 0.2\%$ RO
Hysteresis	Within $\pm 0.2\%$ RO
Repeatability	0.1% RO or less
Rated Output	2.3 mV/V (4600 $\mu\text{m/m}$) $\pm 10\%$
Environmental Capability	
Safe Temp. Range	-10 to 50°C
Comp. Temp. Range	-10 to 50°C
Temp. Effect on Zero Bal.	Within $\pm 0.05\%$ RO/ $^{\circ}\text{C}$
Temp. Effect on Out.	Within $\pm 0.05\%$ / $^{\circ}\text{C}$
Electrical Characteristics	
Safe Excit. Voltage	15 V AC or DC
Recom. Excit. Voltage	1 to 10 V AC or DC
Input Resistance	345 to 460 Ω
Output Resistance	345 to 355 Ω
Mechanical Properties	
Safe Overload Rating	150%

Dimensions

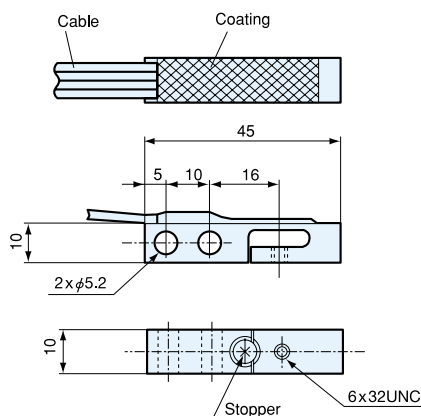

● Beam Type for Special Installation

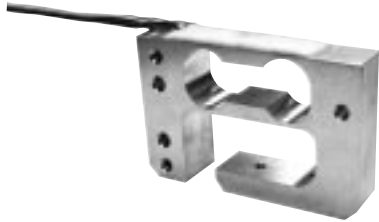

Dimensions

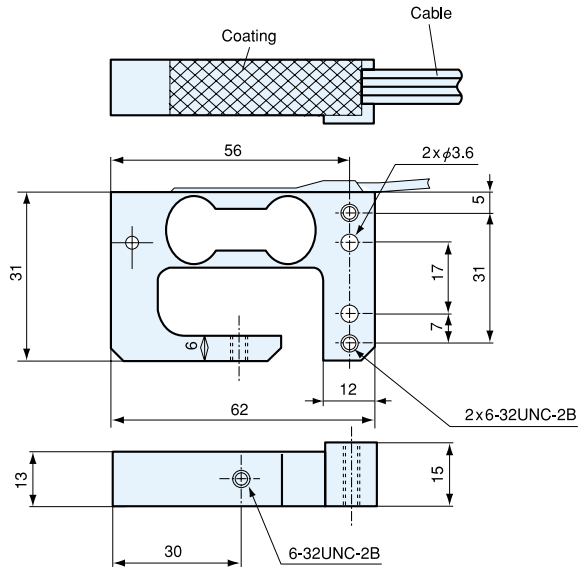

Specifications

Performance	
Rated Capacity	30 to 200 N
Nonlinearity	Within $\pm 0.2\%$ RO
Hysteresis	Within $\pm 0.2\%$ RO
Repeatability	0.1% RO or less
Rated Output	2.3 mV/V (4600 $\mu\text{m/m}$) $\pm 15\%$
Environmental Capability	
Safe Temp. Range	-10 to 50°C
Comp. Temp. Range	-10 to 50°C
Temp. Effect on Zero Bal.	Within $\pm 0.05\%$ RO/°C
Temp. Effect on Out.	Within $\pm 0.05\%$ /°C
Electrical Characteristics	
Safe Excit. Voltage	15 V AC or DC
Recom. Excit. Voltage	1 to 10 V AC or DC
Input Resistance	345 to 460 Ω
Output Resistance	345 to 355 Ω
Mechanical Properties	
Safe Overload Rating	150%

● For Injection Molding Machine



Dimensions

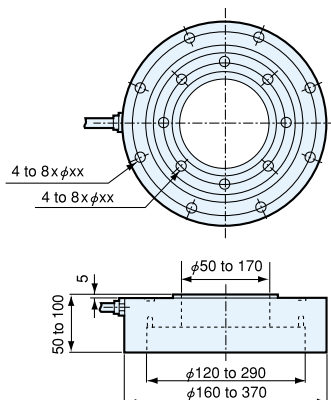

Specifications

Performance	
Rated Capacity	50 to 800 kN
Nonlinearity	Within $\pm 1\%$ RO
Hysteresis	Within $\pm 1\%$ RO
Repeatability	0.5% RO or less
Rated Output	1 mV/V (2000 $\mu\text{m/m}$) $\pm 5\%$
Environmental Capability	
Safe Temp. Range	-10 to 70°C
Comp. Temp. Range	0 to 60°C
Temp. Effect on Zero Bal.	Within $\pm 0.015\%$ RO/°C
Temp. Effect on Out.	Within $\pm 0.015\%$ /°C
Electrical Characteristics	
Safe Excit. Voltage	20 V AC or DC
Recom. Excit. Voltage	1 to 12 V AC or DC
Input Resistance	345 to 450 Ω
Output Resistance	350 Ω $\pm 5\%$
Mechanical Properties	
Safe Overload Rating	150%

● For Elevator



Dimensions

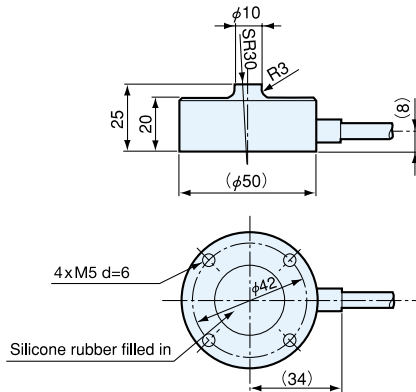

Specifications

Performance	
Rated Capacity	10 kN
Nonlinearity	Within $\pm 0.5\%$ RO
Hysteresis	Within $\pm 0.5\%$ RO
Repeatability	0.1% RO or less
Rated Output	2 mV/V (4000 $\mu\text{m/m}$) $\pm 5\%$
Environmental Capability	
Safe Temp. Range	-20 to 80°C
Comp. Temp. Range	-10 to 70°C
Temp. Effect on Zero Bal.	Within $\pm 0.05\%$ RO/°C
Temp. Effect on Out.	Within $\pm 0.05\%$ /°C
Electrical Characteristics	
Safe Excit. Voltage	20 V AC or DC
Recom. Excit. Voltage	1 to 12 V AC or DC
Input Resistance	350 $\Omega \pm 15 \Omega$
Output Resistance	350 $\Omega \pm 15 \Omega$
Mechanical Properties	
Safe Overload Rating	150%
Weight	Approx. 240 g

● For Rolling Stock



Dimensions

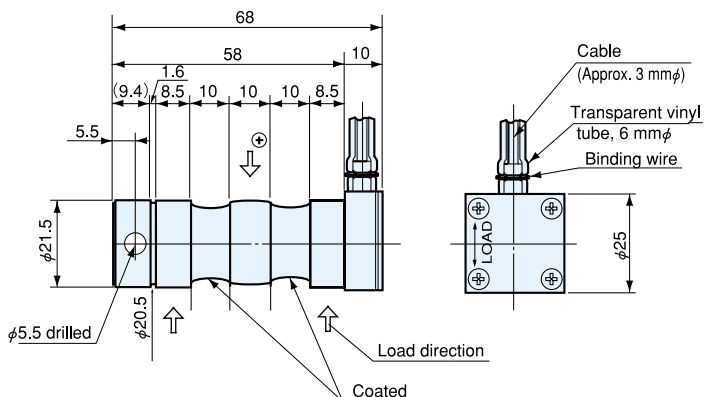

Specifications

Performance	
Rated Capacity	20 kN
Nonlinearity	Within $\pm 2\%$ RO
Hysteresis	Within $\pm 2\%$ RO
Rated Output	Approx. 1.5 mV/V (3000 $\mu\text{m/m}$)
Environmental Capability	
Safe Temp. Range	-10 to 70°C
Comp. Temp. Range	0 to 60°C
Temp. Effect on Zero Bal.	Within $\pm 0.05\%$ RO/°C
Temp. Effect on Out.	Within $\pm 0.05\%$ /°C
Electrical Characteristics	
Safe Excit. Voltage	15 V AC or DC
Recom. Excit. Voltage	1 to 10 V AC or DC
Input Resistance	350 $\Omega \pm 3 \Omega$
Output Resistance	350 $\Omega \pm 3 \Omega$
Mechanical Properties	
Safe Overload Rating	150%

Special Accessories to Load Cells

■ Saddles in the CA-B/C Series

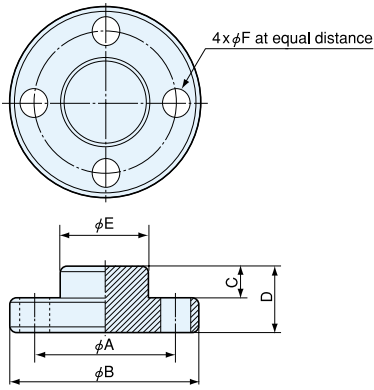

Model	Applicable Load Cell	φ A	φ B	C	D	φ E	φ F	Hexagon Socket Head Cap Screw	Weight (App.)
CA-1B	LU-50 to 500KE LCS-500K, 1TD	43	58	9	19	27	7	M6	300 g
CA-2B	LCK-A-5 to 20KN LTZ-50K to 2TA LUH-50 to 500KF LUB-B, LUB-100, 200KC	38	53	9	19	24	7	M6	200 g
CA-10B	LC-5, 10TV LCK-A-50, 100KN LCS-2,5TD, 10TE LC-1 to 5TSH (L/R)-7 LTZ-5TA	80	98	12	24	60	11	M10	1 kg
CA-50B	LC-20TV LCV-A-500KN LCK-A-200KN LCH-10, 20TF LC-50TE, LCS-20TE LC-10, 20TSH (L/R)-7	100	118	13	28	80	11	M10	1.8 kg
CA-1C	LC-500KJ	43	58	10	20	27	7	M6	300 g
CA-10C	LC-1 to 5TJ	80	98	13	25	60	11	M10	1 kg
CA-50C	LC-10, 20TJ	100	118	15	30	80	11	M10	1.8 kg
CA-1MH	LCV-A-1MN	128	156	25	40	100	13	M12	4 kg

CA-C series is made of SUS.

■ Mount Bases CF-50 to 130, 80C to 90C

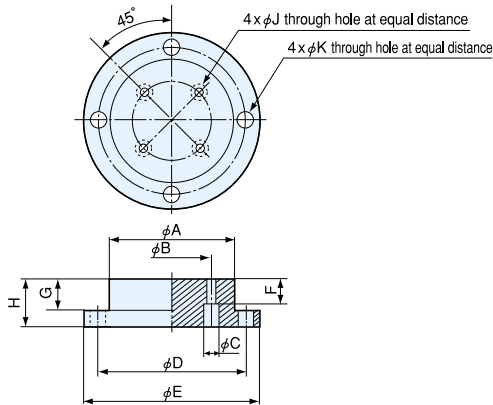

Model	Applicable Load Cell	φ A	φ B	φ C	φ D	φ E	F	G	H	φ J	φ K	Hexagon Socket Head Cap Screw	Weight (App.)
CF-50	LC-5TV LU-50 to 200KE	80	50	10	96	112	13	20	30	5.5	9	4-M5 L=20	1.5 kg
CF-60	LC-10TV LC-G LU-5 to 20KA	90	60	13	106	122	13	20	30	7	9	4-M6 L=20	1.8 kg
CF-80	LC-20TV LCS-500KD to 10TE LU-50 to 500KE LUH-50 to 500KF	100	80	16	124	148	18	25	40	9	13	4-M8 L=25	3.9 kg
CF-90	LCS-20TE	120	90	16	144	168	22	30	50	9	13	4-M8 L=30	5.8 kg
CF-110	LC-50TE, LCH-10TF	160	110	16	184	208	22	30	50	9	13	4-M8 L=35	9.8 kg
CF-130	LCH-20TF	186	130	16	210	234	22	30	50	9	13	4-M8 L=30	12.9 kg
CF-80C	LC-500K to 5TJ	100	80	16	124	148	18	25	40	9	13	4-M8 L=25	3.9 kg
CF-90C	LC-10, 20TJ	120	90	16	144	168	22	30	50	9	13	4-M8 L=30	5.8 kg
CF-113F	LCV-A-500KN	130	113	18	154	178	35	30	50	11	13	4-M10 L=45	7 kg
CF-130F	LCV-A-1MN	150	130	20	184	208	35	30	50	13	13	4-M12 L=50	9 kg

Hexagon socket head cap screw is a standard provision.
CF-C series is made of SUS.

■ Mount Bases CF-6 to 24

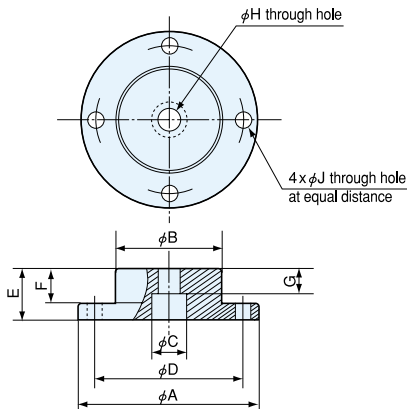

Model	Applicable Load Cell	φ A	φ B	φ C	φ D	E	F	G	φ H	φ J	Hexagon Socket Head Cap Screw	Weight (App.)
CF-6	LTZ-50, 100KA	88	56	14	72	20	10	10	7	7	M6 P=1 L=20	700 g
CF-12	LTZ-200K to 1TA	105	70	24	87	30	20	14	13	9	M12 P=1.75 L=30	1.4 kg
CF-18	LTZ-2TA	105	70	32	87	30	20	6	19	9	M18 P=1.5 L=30	1.5 kg
CF-24	LTZ-5TA	148	100	44	124	40	25	8	25	13	M24 P=2 L=40	4 kg

Hexagon socket head cap screw is a standard provision.

■ Patches CW-005 to 5

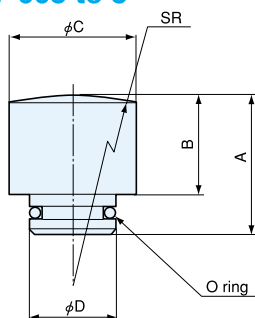

Model	Applicable Load Cell	A	B	φ C	φ D	R	Weight (App.)
CW-005	LUB-5 to 50KB	22	15	13	8	20	18 g
CW-02	LUB-100, 200KB LUB-100, 200KC	22	15	16	10	30	27 g
CW-1	LUB-500K, 1TB LUB-500K, 1TC	30	20	24	16	50	85 g
CW-2	LUB-2TB LUB-2TC	38	26	30	20	70	170 g
CW-5	LUB-5TC	54	39	42	28	70	480 g

Patches CWM-6 to 24

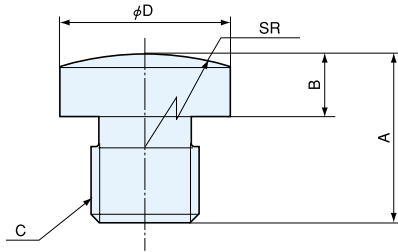

Model	Applicable Load Cell	A	B	C	ϕ D	R	Weight (Approx.)
CWM-6	LTZ-50, 100KA	10	4	M6 P=1	10	30	2 g
CWM-12	LTZ-200K to 1TA	19	7	M12 P=1.75	19	30	25 g
CWM-18	LTZ-2TA	28	10	M18 P=1.5	26	70	70 g
CWM-24	LTZ-5TA	37	17	M24 P=2	36	70	200 g

Movable Saddles ER-1B to 20B, 1D to 20D

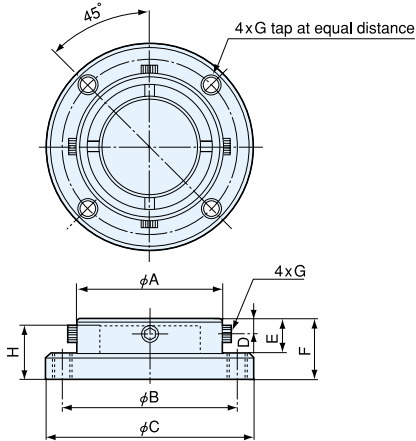

Model	Applicable Load Cell	ϕ A	ϕ B	ϕ C	D	E	F	G	H	Weight (Approx.)
ER-1B	LU-50K to 500KE LCS-50KD, 1TD	100	118	138	10	25	40	M12	39	2.2 kg
ER-2B	LCH-50 to 500KF, LCF-A-500N to 20KN LUH-50 to 500KF	75	90	108	10	22	35	M8	34	1.5 kg
ER-5B	LCH-1 to 5TF LC-5TV, LUH-1 to 5TF LCS-2, 5TD	110	128	148	15	30	50	M12	49	4.3 kg
ER-10B	LC-10TV, LCS-10TE LCH-10TF, LUH-10TF	140	158	178	15	40	60	M12	59	7.5 kg
ER-20B	LC-20TV, LUH-20TF, LCS-20TE LCH-20TF	160	178	198	20	50	80	M12	78	13.1 kg
ER-1D	LC-500KJ	100	118	138	10	25	40	M12	78	2.2 kg
ER-5D	LC-1,2TJ	110	128	148	15	30	50			4.3 kg
ER-10D	LC-5TJ	140	158	178	15	40	60			7.5 kg
ER-20D	LC-10TJ	160	178	198	20	50	80			13.1 kg

ER-D series is made of SUS.

Mount Base with Stopper LD-005

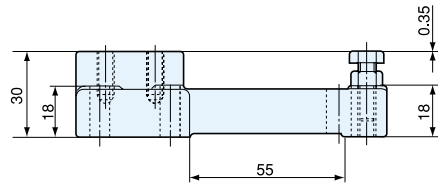
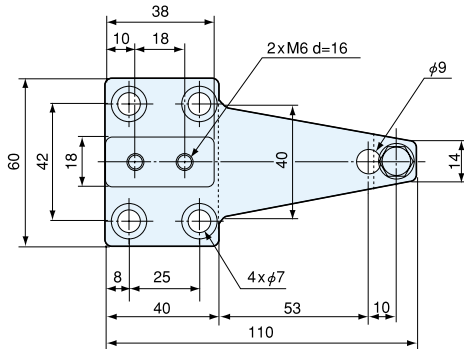

Applicable load cells are LUB-5 to 50KB.
Weight: Approx. 600 g

Spacers LE-005 to 2

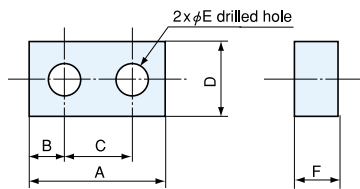

Model	Applicable Load Cell	A	B	C	D	ϕ E	F	Weight (Approx.)
LE-005	LUB-5 to 50KB	36	9	18	22	6.6	13	74 g
LE-02	LUB-100, 200KB LUB-100, 200KC	40	10	20	22	9	13	77 g
LE-1	LUB-500K, 1TB LUB-500K, 1TC	100	25	50	40	13.5	20	590 g
LE-2	LUB-2TB LUB-2TC	118	29	60	50	17.5	25	1.1 kg

Junction Boxes SJB-4C/4D

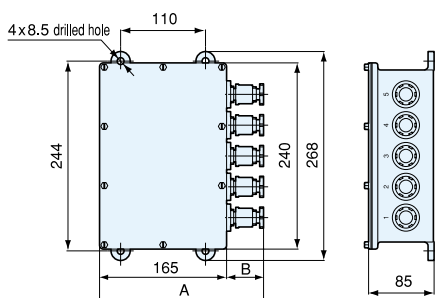

Model	A	B	Through fitting	Cable	Applicable Diameter
SJB-4C	212	47	15c	4-conductor (0.5 mm ²) repletion type	10 to 11 mm
SJB-4D	208	43	10b	4-conductor (0.3 mm ²) shielded cable	7 to 8 mm

Rotating Attachments RJ-02 to 20

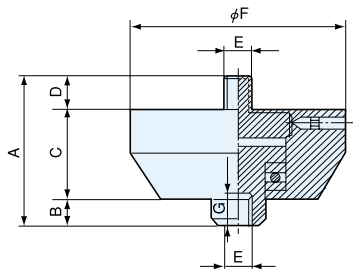

Model	Applicable Load Cell	A	B	C	D	E	ϕF	G	Weight (App.)	Rated Capacity	Max. Allowable Static Load
RJ-02	LU-50 to 200KE	55	10	35	10	M8 P=1.25	80	12	1.2 kg	2 kN	11.7 kN
RJ-05	LU-500KE	58	10	35	13	M12 P=1.75	100	17	1.7 kg	5 kN	21.5 kN
RJ-1	LU-1TE	82	10	52	20	M14 P=2	100	22	2.8 kg	10 kN	37.2 kN
RJ-2	LU-2TE	82	10	52	20	M18 P=1.5	100	22	2.8 kg	20 kN	64.7 kN
RJ-5	LU-5TE	118	14	71	33	M26 P=2	112	35	5.1 kg	50 kN	136.3 kN
RJ-10	LU-10TE	158	19	96	43	M36 P=2	138	45	10.4 kg	100 kN	215.7 kN
RJ-20	LU-20TE	226	25	140	61	M50 P=3	186	65	28.3 kg	200 kN	431.4 kN

Rotating Attachments RJ-02 to 20B

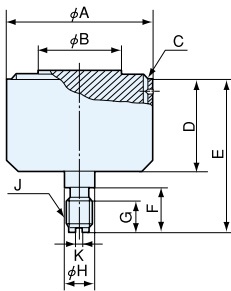

Model	Applicable Load Cell	ϕA	ϕB	C	D	E	F	G	ϕH	J	K	Weight (App.)	Rated Capacity	Max. Allowable Static Load
RJ-02B	LT-50 to 200KFH LT-50 to 200KFL	74	42.5	M68	48	78	23	17	15	M12 P=1.75	1.6	1.5 kg	2 kN	20.5 kN
RJ-05B	LT-500KFH LT-500KFL	78	42.5	M72	58	94	27	20	20	M14 P=2	3	1.9 kg	5 kN	31.3 kN
RJ-1B	LT-1TFH LT-1TFL	78	42.5	M72	65	109	33	26	25	M18 P=1.5	3	2.7 kg	10 kN	41.1 kN
RJ-2B	LT-2TFH LT-2TFL	82	42.5	M72	72	127	44	35	30	M24 P=2	3	2.8 kg	20 kN	48.0 kN
RJ-5B	LT-5TFH LT-5TFL	134	63	M110	107	179	55	45	50	M39 P=3	6	10.9 kg	50 kN	166.7 kN
RJ-10B	LT-10TFH LT-10TFL	166	83	M140	147	244	75	63	70	M56 P=3	6	24.0 kg	100 kN	254.9 kN
RJ-20B	LT-20TFH LT-20TFL	218	111	M190	191	320	100	85	90	M76 P=4	8	54.7 kg	200 kN	431.4 kN

Ball Joints TU-12 to 76B

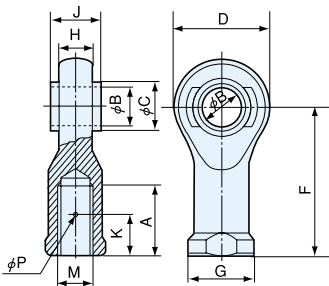

Model	Applicable Load Cell	A	ϕB	ϕC	D	F	G	H	J	K	M	ϕP	Weight (App.)	Rated Capacity	Max. Allowable Static Load
TU-12B	LT-50 to 200KFH LT-50 to 200KFL	24	12	15.43	30	50	22	12	16	14.5	M12 P=1.75	1.8	200 g	2 kN	31.3 kN
TU-14B	LT-500KFH LT-500KFL	27	14	16.86	34	57	25	13.5	19	16	M14 P=2	3.2	200 g	5 kN	42.1 kN
TU-18B	LT-1TFH LT-1TFL	36	18	21.89	42	71	31	16.5	23	21	M18 P=1.5	3.2	300 g	10 kN	82.3 kN
TU-24B	LT-2TFH LT-2TFL	48	25	29.60	56	94	42	22	31	30.5	M24 P=2	3.2	700 g	20 kN	146.1 kN
TU-39B	LT-5TFH LT-5TFL	73	40	46.28	85	140	65	33	48	49.5	M39 P=3	6.3	2.2 kg	50 kN	160.0 kN
TU-56B	LT-10TFH LT-10TFL	85	40	56.0	120	173	98	39.5	60	68.5	M56 P=3	6.3	5.8 kg	100 kN	294.1 kN
TU-76B	LT-20TFH LT-20TFL	110	50	68.5	140	220	127	49.0	75	92	M76 P=4	8.5	12 kg	200 kN	588.3 kN

Ball Joints TU-8 to 50, 6C to 24C

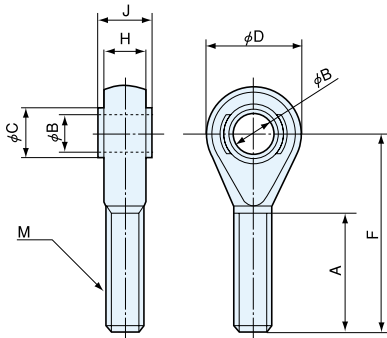

Model	Applicable Load Cell	A	ϕB	ϕC	ϕD	F	H	J	M	Weight (App.)	Rated Capacity	Max. Allowable Static Load
TU-6C	L TZ-50, 100KA	22	6	9	18	36	6.7	9	M6 P=1	20 g	1 kN	4.9 kN
TU-8	LU-50 to 200KE LUR-A-SA1	29	8	10.4	22	46	8.25	11	M8 P=1.25	100 g	2 kN	12.7 kN
TU-12	LU-500KE LUH-50 to 200KF	37	12	15.43	30	62	13.25	16	M12 P=1.75	100 g	10 kN	31.3 kN
TU-12C	L TZ-200K to 1TA											
TU-14	LU-1TE LUH-1TF	38	14	18	37	64	14.25	17	M14 P=2	200 g	10 kN	42.1 kN
TU-18	LU-2TE LUH-500KF, 2TF	44	18	21.89	42	72	16.5	23	M18 P=1.5	300 g	20 kN	82.3 kN
TU-18C	L TZ-2TA											
TU-24C	L TZ-5TA	66	25	35.5	70	113	26.5	37	M24 P=2	1 kg	50 kN	182.4 kN
TU-26	LU-5TE LUH-5TF	68	25	33.5	70	113	26.5	37	M26 P=2	1 kg	50 kN	182.4 kN
TU-36	LU-10TE LUH-10TF	115	40	54	105	173	39.5	60	M36 P=2	3.2 kg	100 kN	352.0 kN
TU-50	LU-20TE LUH-20TF	122	50	66.5	136	210	49	75	M50 P=3	7.2 kg	200 kN	672.7 kN

TU-6C, 12C, 18C and 24C are designed for the LTZ-A series and come standard with hexagon socket head cap screw.

■ Hooks TH-05 to 5D

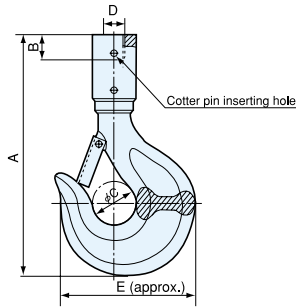

Model	Applicable Load Cell	A	B	φC	D	E (App.)	Weight (App.)	Rated Capacity	Max. Allowable Static Load
TH-02D	LT-50 to 200KFH LT-50 to 200KFL	182	17	31	M12 P=1.75	93	1 kg	2 kN	15 kN
TH-05D	LT-500KFH LT-500KFL	182	19	31	M14 P=2	93	1.05 kg	5 kN	25 kN
TH-1D	LT-1TFH LT-1TFL	212	25	40	M18 P=1.5	115	1.2 kg	10 kN	40 kN
TH-2D	LT-2TFH LT-2TFL	272	33	50	M24 P=2	150	3.4 kg	20 kN	60 kN
TH-5D	LT-5TFH LT-5TFL	430	54	65	M39 P=3	208	11.8 kg	50 kN	120 kN

■ Hooks TH-05 to 5C

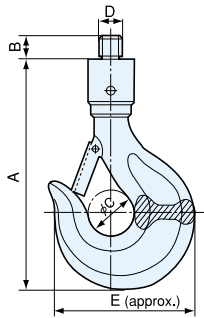

Model	Applicable Load Cell	A	B	φC	D	E (App.)	Weight (App.)	Rated Capacity	Max. Allowable Static Load
TH-02C	LU-50 to 200KE	171	11	31	M8 P=1.25	93	1 kg	2 kN	15 kN
TH-05C	LU-500KE	171	15	31	M12 P=1.75	93	1.05 kg	5 kN	25 kN
TH-1C	LU-1TE	197	20	40	M14 P=2	115	1.2 kg	10 kN	40 kN
TH-2C	LU-2TE	252	26	50	M18 P=1.5	150	3.4 kg	20 kN	60 kN
TH-5C	LU-5TE	394	35	65	M26 P=2	208	11.6 kg	50 kN	120 kN

■ Hooks TH-10 and 20B

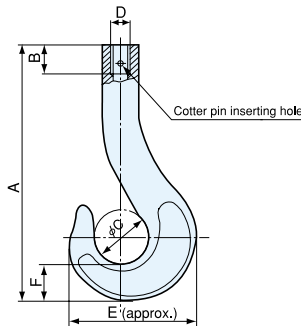

Model	Applicable Load Cell	A	B	φC	D	E (App.)	F	Weight (App.)	Rated Capacity	Max. Allowable Static Load
TH-10B	LT-10TFH LT-10TFL	503	70	80	M56 P=3	220	80	25.5 kg	100 kN	196.1 kN
TH-20B	LT-20TFH LT-20TFL	654.5	93	105	M76 P=4	305	115	61.7 kg	200 kN	451.1 kN

■ Shackles TR-02 to 5D

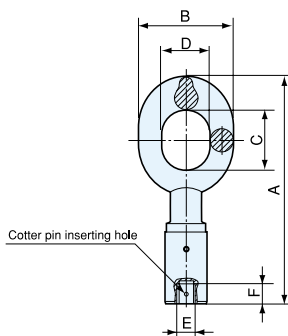

Model	Applicable Load Cell	A	B	C	D	E	F	Weight (App.)	Rated Capacity	Max. Allowable Static Load
TR-02D	LT-50 to 200KFH LT-50 to 200KFL	160	65	45	35	M12 P=1.75	17	600 g	2 kN	15 kN
TR-05D	LT-500KFH LT-500KFL	160	65	45	35	M14 P=2	19		5 kN	25 kN
TR-1D	LT-1TFH LT-1TFL	192	76	52	40	M18 P=1.5	25	1.05 kg	10 kN	40 kN
TR-2D	LT-2TFH LT-2TFL	237	96	61	50	M24 P=2	33	2 kg	20 kN	60 kN
TR-5D	LT-5TFH LT-5TFL	358	145	95	75	M39 P=3	54	6 kg	50 kN	120 kN

■ Shackles TR-02 to 5C

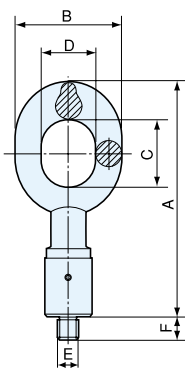

Model	Applicable Load Cell	A	B	C	D	E	F	Weight (App.)	Rated Capacity	Max. Allowable Static Load
TR-02C	LU-50 to 200KE	149	65	45	35	M8 P=1.25	11	600 g	2 kN	15 kN
TR-05C	LU-500KE	149	65	45	35	M12 P=1.75	15		5 kN	25 kN
TR-1C	LU-1TF	177	76	52	40	M14 P=2	20	1.05 kg	10 kN	40 kN
TR-2C	LU-2TE	217	96	60	50	M18 P=1.5	26	2 kg	20 kN	60 kN
TR-5C	LU-5TE	322	145	90	75	M26 P=2	35	5.8 kg	50 kN	120 kN

Shackles TR-10 and 20B

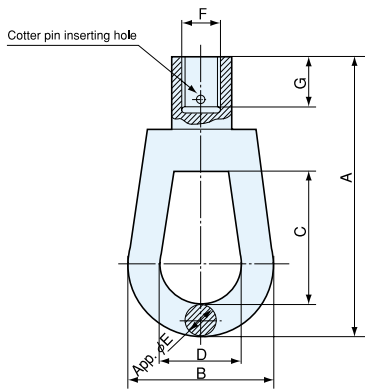

Model	Applicable Load Cell	A	B	ϕ C	D	E (App.)	F	G	Weight (App.)	Rated Capacity	Max. Allowable Static Load
TR-10B	LT-10TFH LT-10TFL	331	182	115	90	46	M56 P=3	74	14 kg	100 kN	147.0 kN
TR-20B	LT-20TFH LT-20TFL	425	240	160	120	60	M76 P=4	97	27.1 kg	200 kN	294.1 kN

Hangers TW-002 and 005

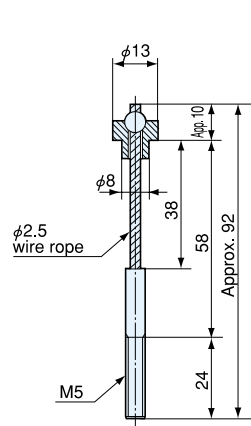

TW-002 (for LUB-5 to 20KB)
Weight: Approx. 13 g

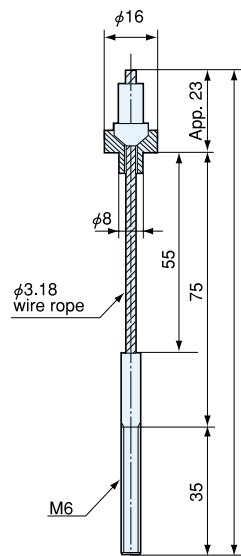

TW-005 (for LUB-5 to 50KB)
Weight: Approx. 25 g

Hangers TW-02 to 2

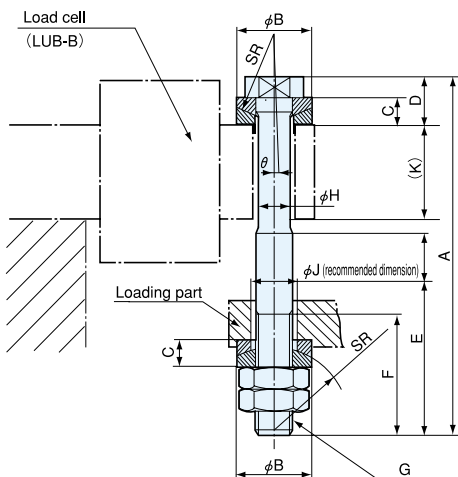

Model	Applicable Load Cell	A	ϕ B	C	D	E	F	G	ϕ H	ϕ J	(K)	R	θ	Movable Range in Lateral Direction	Weight (App.)
TW-02	LUB-100, 200KB LUB-100, 200KC	90	20	8	13	53	35	M8	6	12	20	20	2°40'	3.5	70 g
TW-1	LUB-500KB, 1TB LUB-500KC, 1TC	133	28	10	18	75	45	M14	12	18	35	30	1°40'	3.5	250 g
TW-2	LUB-2TB, LUB-2TC	165	34	10	20	95	60	M18 P=1.5	15	22	44	40	1°40'	4.5	500 g

Rated Capacity

Design value of the upper limit in the measuring range.

Rated Load

Upper limit of load at which the load cell performs to the specifications.

Overload

Load exceeding the rated capacity.

Safe Overload Rating

Maximum overload which may not cause any permanent change to stated specifications, expressed in percentage of the rated capacity.

Ultimate Overload Rating

Maximum overload which can be applied without causing any structural damage, expressed in percentage of the rated capacity.

Rated Output

Value obtained by deducting the output under no load from the output under the rated capacity. Usually, it is expressed in mV/V, mA or equivalent strain.

Rated Output Voltage

Rated output expressed with the output voltage at the open end. It is expressed together with the excitation voltage.

Rated Output Current

Rated output expressed with the current flowing when connected to a prescribed load impedance. It is expressed together with the excitation voltage and load impedance.

Rated Output Equivalent Strain

Rated output expressed with a value converted into strain, with the gauge factor 2.00.

Sensitivity

Ratio of changing output to changing load. Usually, it is expressed in mV/V or $\mu\text{m}/\text{m}$ (microstrain) per 1V excitation voltage.

Calibration Constant

Ratio of the rated load to the rated output.

Nonlinearity

Maximum deviation of output between the calibration curve in the increasing load cycle and the reference line (straight line drawn from the output under no load to the rated output under the rated capacity); expressed in percentage of the rated output.

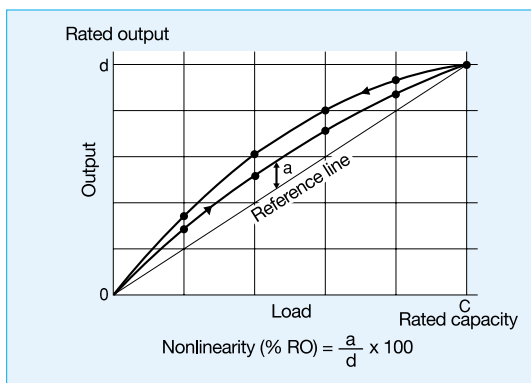

Hysteresis

Difference of output between the calibration curve traced in the increasing load cycle and that in the decreasing load cycle. Usually, the calibration curve is reciprocated between the null load and the rated capacity and the maximum difference in outputs corresponding to the same load is defined as the hysteresis, expressed in percentage of the rated capacity.

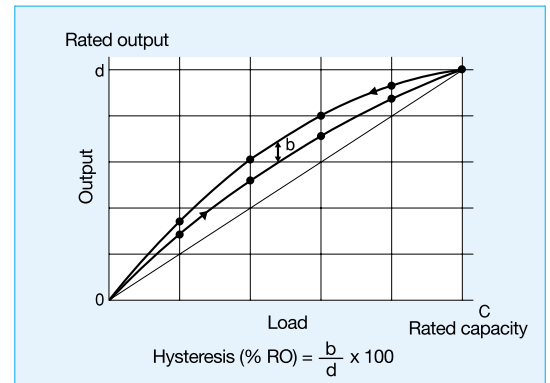

Natural Frequency

Frequency due to free vibration of transducers under no load.

Frequency Response Range

Frequency range in which the output can respond to the input at the same amplitude and phase within certain range of error when the input is steady-state sinusoidal.

Excitation Voltage

Voltage applied to the input terminal of transducers.

Recommended Excitation Voltage

Maximum excitation voltage with which the transducers can perform to the specifications.

Safe Excitation Voltage

Maximum excitation voltage with which the transducer may not perform to the specifications but when the recommended excitation voltage is recovered, the transducer performs to the specifications.

Input/Output Resistance

Resistance of input or output terminal. Use of the term is limited to the indication of the nominal resistance of an input or output terminal.

Input Terminal Resistance

Resistance between input terminals with output terminals open under no load.

Output Terminal Resistance

Resistance between output terminals with input terminals open under no load.

Temperature Effect on Zero Balance

Change of zero due to change of ambient temperature; expressed as a change of zero per 1°C in percentage of the rated output ($xx\% \text{ RO}/^\circ\text{C}$).

Temperature Effect on Output

Change of gain due to change of ambient temperature, expressed as a change of zero per °C in percentage (xx%/°C).

Compensated Temperature Range

Temperature range which guarantees that the transducer performs to the specifications with regard to temperature effects on output and zero balance.

Safe Temperature Range

Temperature range in which the transducers may not perform to the specifications but does not receive any permanent change in the specifications.

Repeatability

Maximum difference between output variables initiated by repeatedly applying the same load under the same conditions. Usually, it is measured using the rated load and expressed in percentage of the average rated output.

Zero Balance

Output under no load with the transducer placed in the prescribed posture. Usually, it is expressed in mV/V, strain or percentage of the rated output.

Zero Stability

Degree at which the transducers keep the zero under prescribed conditions.

Stability

Capability of the transducers to keep the characteristics for a comparatively long period of time. Unless otherwise noted, it is the capability to maintain the characteristics such as calibration factor and non-linearity obtained at the initial calibration, under room conditions and for a prescribed period. It may be called degree of stability if expressed quantitatively with a numeric value.

Interference

With a multiple component transducer, effect of the rated load applied to one component on the output of other components; expressed in percentage of the rated output of each component.

Recommended Fastening Torque

Tightening torque required to let the transducer perform to the specifications.

Best Straight Line

Straight line placed in the middle of 2 parallel straight lines which are traced with a minimum distance while putting the calibration curve in between.

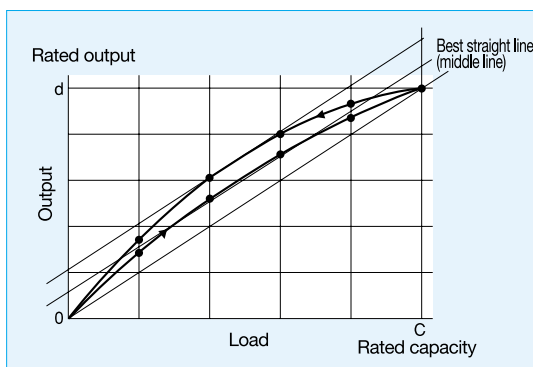

Resonance Frequency

Frequency of input mechanical vibration causing maximum response output of the transducer.

Cycling Life

Minimum number of repeated operations under the rated or prescribed load without exceeding allowable ranges of specified characteristics.

Degrees of Protection

Degree of protection against invasion of a solid matter or water; expressed using IP code stipulated in JIS C 0920.

Weight

Expressed in kg or g. If items other than the mainframe are included, the fact is noted.

Material

Material of the mainframe, bottom panel or cable outlet is expressed using the type code stipulated in JIS. Surface treatment such as plating or painting is also noted.

Cable

Cable to be connected to the transducers through the connector or cable connected directly to the internal circuit. Nominal cross section of conductor, number of conductors, material of shield or sheath, length and nominal outer diameter and condition of the tip are stated.

Zero Float

Zero float due to application of one cycle of rated tension and compression loads; expressed in percentage of the rated output. It is also called cyclic zero shift.

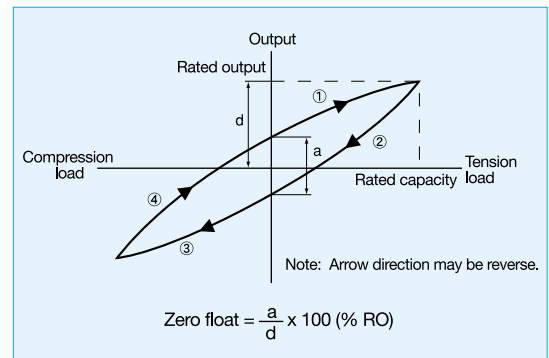

WGA-900A

Instrumentation Amplifier



Enables monitoring of applied pressure change in waveform while checking in numeric value.

This realizes easy initial condition setting without using any oscilloscope. Numeric indication in ± 99999 , wide measuring range of ± 3.2 mV/V and 5 comparators enable delicate monitoring and control according to the application. MONITOR output, RS-232C and I/O port are provided standard, thereby facilitating construction of an ideal concentrated management/control system. BCD output, D-A output or RS-485 card is also available optionally.

- Touch panel for easy operation
- Enlarged numeric indication for easy confirmation from a distant place
- NDIS connector facilitating connection of KYOWA load cell
- SD card drive provided standard
- TEDS compatible for easy calibration
- 24 bits, high-speed sampling at 4000 times/sec
- Additional analog circuit for peak/bottom detection
- KYOWA original cursor function



Numeric Display



Enlarged Numeric Display



Waveform Display



JQA-0821
JQA-EM4824

Specifications are subject to change without notice for improvement.



Safety precautions

Be sure to observe the safety precautions given in the instruction manual, in order to ensure correct and safe operation.

Reliability through integration



KYOWA ELECTRONIC INSTRUMENTS CO., LTD.

Overseas Department:

3-5-1, Chofugaoka, Chofu, Tokyo 182-8520, Japan
Phone: +81-42-489-7220 Facsimile: +81-42-488-1122
<http://www.kyowa-ei.com>
e-mail: overseas@kyowa-ei.co.jp

Cat. No. 201d-U2

Manufacturer's Representative



KVALITEST
— INDUSTRIAL —

Printed in Japan 10/11